

Multi-axis force-torque-sensor K6D40



Measuring ranges	F _x /N	F _y /N	F _z /N	M _x /Nm	M _y /Nm	M _z /Nm
K6D40 200N/5Nm	200	200	500	5	5	10
K6D40 500N/20Nm	500	500	2000	20	20	40

Description

The K6D40 multi-component sensor is designed to measure the forces and torques on three mutually perpendicular axes.

Owing to this sensor's very light weight of only 160 g (K6D40 200 N / 5 Nm) or 450 g (K6D40 500 N / 20 Nm), it is very well suited for use in robotics, e.g.

1. For collision detection
2. "Teach-In"
3. Presence detection and error detection
4. Force or torque-controlled operation
5. Load measurement in medicine, prosthetics, orthopaedic engineering or gait analysis
6. Measurement in sports medicine
7. Comfort / ergonomics measurements

The force and torque loadings are evaluated e.g. using a GSV-1A8USB measurement amplifier. The 6 load values can be calculated using a Windows DLL or using LabVIEW with the aid of a digital calibration document provided. The calibration document contains the individual calibration factors and error corrections for the sensor.

The K6D40 200 N / 5 Nm sensor is made from aluminium alloy with a stainless steel housing. The K6D40 500N/20Nm sensor is made entirely of stainless steel.

Dimensions

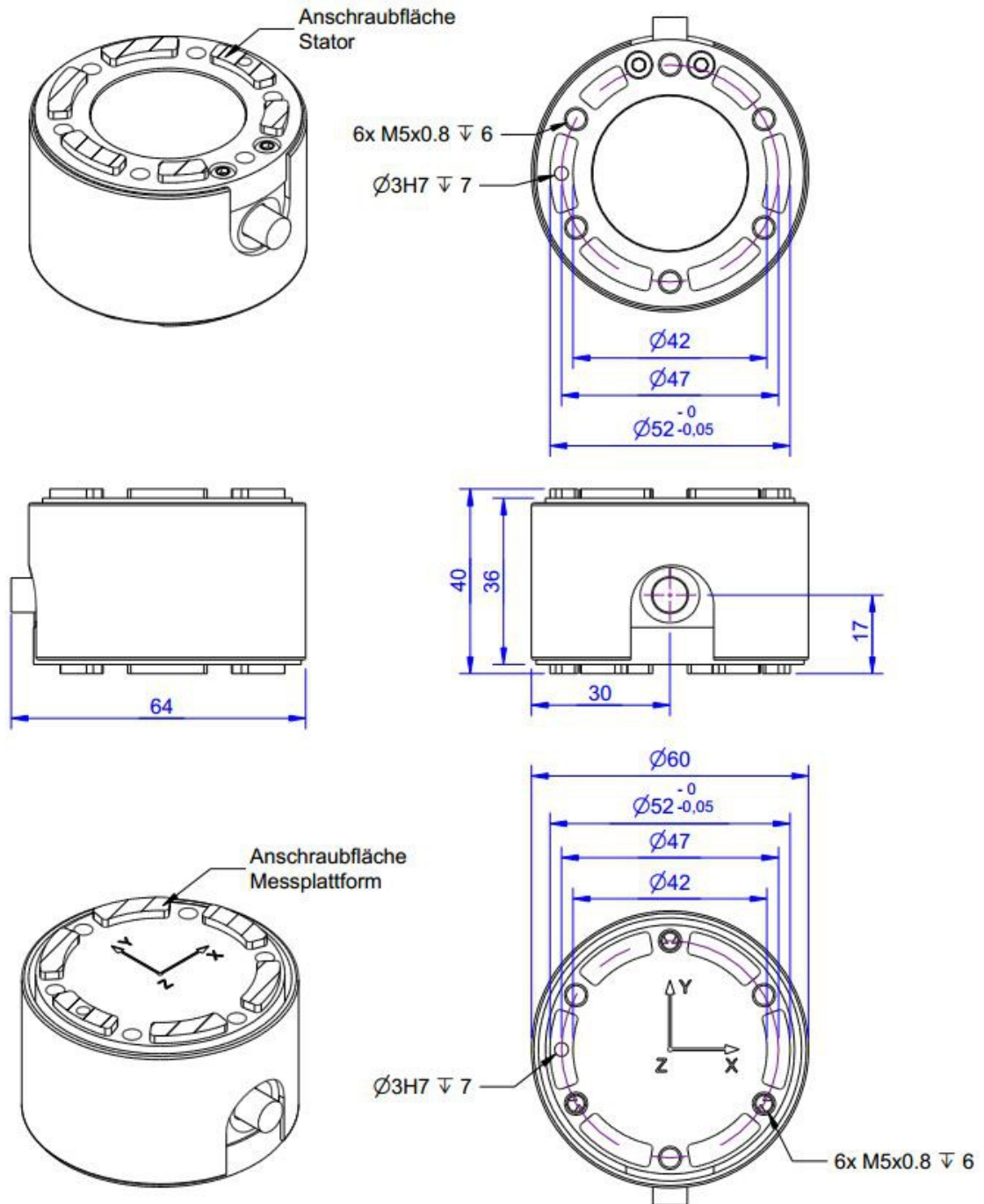

Technical Data

Design & Material		
Type		Measuring platform
Material		aluminum 200N stainless steel 500N
Dimension	mm x mm	Ø60 x 40
Force transmission / fastening		6x M5
Mechanical Data		
Nominal force (FS). x. y. z-Axis	N	200 ... 500
Nominal torque (FS) Mx, My, Mz	Nm	5 ... 20
Operating force	%FS	150
Breaking force	%FS	300
Displacement at FS 1)	mm	ca. 0,1(0,03)
Twist at FS 1)	rad	ca. 0,01 (0,003)
Elektrical Data		
Rated Output 2)	mV/V @ FS	ca. 0,4
Zero signal	mV/V	<2
Max. supply voltage	V	5
Input resistance	Ohm	350 ±10
Output resistance	Ohm	350 ±10
Insulation resistance	Ohm	>2 10 ⁹
Connection, 24	m	5
Accuracy class		
rel. span width 3)	%FS	0,5
rel. linearity deviation	%FS	<0,1
rel. reversal error	%FS	<0,1
Temp. coeff. of the zero signal	%FS/K	<0,1
Temp. coeff. of the nominal output	%RD/K	<0,05
rel. Creep error (30 min)	%FS	<0,1
Temperature		
Nominal temperature range	°C	-10... +70
Operating temperature range	°C	-10 ... +85
Storage temperature range	°C	-10 ... +85
Environmental protection		IP67

Abbreviation : RD: „Reading“; FS: „Full Scale“;

Values () for K6D40 500N / 20Nm of stainless steel;

1) Measured displacement with single-axis loading Fx or Fy or Fz;

2) Reference value with single-axis loading Fz;

3) Repeatability with same installation position and multi-axis loading;

The calibration of the individual axes and the crosstalk are individually determined and documented in a calibration matrix.



Siffness Matrix

K6D40 200N/5Nm

5,8 kN/mm	0,0	0,0	0,0	116 kN	0,0
0,0	5,8 kN/mm	0,0	-116 kN	0,0	0,0
0,0	0,0	32,3 kN/mm	0,0	0,0	0,0
0,0	-116 kN	0,0	9,3 kNm	0,0	0,0
116 kN	0,0	0,0	0,0	9,3 kNm	0,0
0,0	0,0	0,0	0,0	0,0	5,0 kNm

K6D40 500N/20Nm

15,9 kN/mm	0,0	0,0	0,0	319 kN	0,0
0,0	15,9 kN/mm	0,0	-319 kN	0,0	0,0
0,0	0,0	88,5 kN/mm	0,0	0,0	0,0
0,0	-319 kN	0,0	25,5 kNm	0,0	0,0
319 kN	0,0	0,0	0,0	25,5 kNm	0,0
0,0	0,0	0,0	0,0	0,0	13,8 kNm

Accessories

Measurement amplifier

The GSV-1A8/K6D measurement amplifier is provided with a 24-pin plug, thus allowing a 6-axis sensor to be connected. The GSVmulti software calculates the mechanical forces and torques from the 6 output voltages of the individual channels using the calibration matrix.

Calibration matrix

The calibration matrix contains 36 calibration factors for calculating the forces and torques from the 6 output signals of the force sensor. A LabVIEW VI is available for manipulating the calibration matrix.

Software

The GSVmulti software is supplied with the GSV-1A8USB/K6D measurement amplifier. This software enables the calibration matrix to be used and lets the user move the coordinate origin so as to display the moments about any chosen reference point.

A LabVIEW VI is also available to enable users to create their own software.

Mounting the sensor

The force is applied to an annulus / to 6 segments of a circle, 52 mm – 42mm in diameter, on the end faces of the sensor. No force is applied to the area inside the ring with a diameter of 42 mm.

The areas outside the annuli can be used for centring purposes. A centring hole is provided to secure the angular position.

Pin Configuration

Channel	Signal	Description	Colour of wire	PIN
1	+Us1	positive bridge excitation	red	1
	-Us1	negative bridge excitation	black	2
	+Ud1	positive bridge output	green	3
	-Ud1	negative bridge output	white	4
2	+Us2	positive bridge excitation	blue	5
	-Us2	negative bridge excitation	yellow	6
	+Ud2	positive bridge output	purple	7
	-Ud2	negative bridge output	gray	8
3	+Us3	positive bridge excitation	orange	9
	-Us3	negative bridge excitation	brown	10
	+Ud3	positive bridge output	pink	11
	-Ud3	negative bridge output	transparent	12
4	+Us4	positive bridge excitation	green-black	13
	-Us4	negative bridge excitation	black-white	14
	+Ud4	positive bridge output	red-black	15
	-Ud4	negative bridge output	white-black	16
5	+Us5	positive bridge excitation	purple-black	17
	-Us5	negative bridge excitation	yellow-black	18
	+Ud5	positive bridge output	blue-black	19
	-Ud5	negative bridge output	gray-black	20
6	+Us6	positive bridge excitation	pink-black	21
	-Us6	negative bridge excitation	brown-black	22
	+Ud6	positive bridge output	orange-black	23
	-Ud6	negative bridge output	transparent-black	24