

“GR” base program

TRASCO® couplings are dimensionally manufactured to hub types “A” and “B”, the difference being the maximum shaft diameter which hubs can accept (corresponding respectively to the first and second code number). The long hub execution “L” (allows full coverage of the motor shaft) is available in both “A” and “B” executions.

Materials used for manufacture are:

- cast iron grade GG25 (all sizes);
- aluminum, die-casting
- cast iron grade GGG40 and steel upon request.

Approved according to EC standard ATEX 94/9/EC.

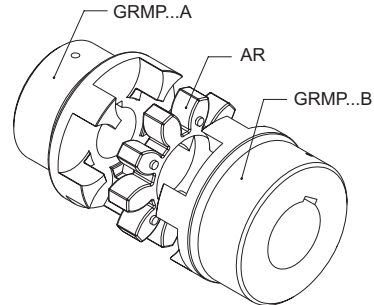
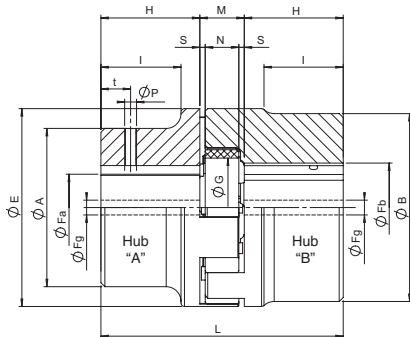

Dimensional specification hubs in GG25

Size	Fa max [mm]	Fb max [mm]	Fg [mm] executions				E [mm]	A [mm]	B [mm]	A execution [mm]			B execution [mm]			AL execution [mm]			BL execution [mm]			M [mm]	S [mm]	N [mm]	G [mm]
			A	B	AL	BL				H	L	I	H	L	I	H	L	I	H	L	I				
19/24	-	24	-	-	-	-	40	-	40	25	66	-	25	66	-	-	-	-	50	-	-	16	2	12	18
24/32	24	32	8	10	8	10	55	40	55	30	78	24	30	78	-	50	118	44	60	138	-	18	2	14	27
28/38	28	38	8	10	8	10	65	48	65	35	90	28	35	90	-	60	140	53	80	180	-	20	2,5	15	30
38/45	38	45	10	12	14	14	80	66	80	45	114	37	45	114	-	80	184	72	110	244	-	24	3	18	38
42/55	42	55	10	12	16	16	95	75	95	50	126	40	50	126	-	110	246	100	110	246	-	26	3	20	46
48/60	48	60	12	12	16	16	105	85	105	56	140	45	56	140	-	110	248	99	140	308	-	28	3,5	21	51
55/70	55	70	15	15	16	16	120	98	120	65	160	52	65	160	-	110	250	97	140	310	-	30	4	22	60
65/75	65	75	15	15	20	20	135	115	135	75	185	61	75	185	-	140	315	126	140	315	-	35	4,5	26	68
75/90	75	90	15	15	22	22	160	135	160	85	210	69	85	210	-	140	320	124	170	380	-	40	5	30	80
90/100	90	100	20	20	30	30	200	160	180	100	245	81	100	245	81	170	385	151	210	465	191	45	5,5	34	100
100/110	115	-	45	-	-	-	225	180	-	110	270	89	110	270	-	-	-	-	-	-	-	50	6	38	113
110/125	125	-	55	-	-	-	255	200	-	120	295	96	120	295	-	-	-	-	-	-	-	55	6,5	42	127
125/145	145	-	55	-	-	-	290	230	-	140	340	112	140	340	-	-	-	-	-	-	-	60	7	46	147
140/160	160	-	55	-	-	-	320	255	-	155	375	124	-	-	-	-	-	-	-	-	-	65	7,5	50	165
160/185	185	-	75	-	-	-	370	290	-	175	425	140	-	-	-	-	-	-	-	-	-	75	9	57	190
180/200	200	-	80	-	-	-	420	325	-	195	475	156	-	-	-	-	-	-	-	-	-	85	10,5	64	220

Material: 19/24 Sintered steel - from 24/32 to 90/100 Cast Iron - Ductile Iron over.
Keyway according to DIN 6885 sheet 1 - JS9

Dimensional specification hubs in aluminum

Size	Fa max [mm]	Fb max [mm]	Fg [mm] execution		E [mm]	A [mm]	B [mm]	L [mm]	H [mm]	M [mm]	S [mm]	N [mm]	I [mm]	G [mm]	t [mm]	P [mm]
			A	B												
19/24	-	24	-	-	40	40	40	66	25	16	2	12	-	18	10	M5
24/32	24	32	-	-	55	40	55	78	30	18	2	14	24	27	10	M5
28/38	28	38	12	28	65	48	65	90	35	20	2,5	15	28	30	15	M6
38/45	38	45	22	38	80	66	77	114	45	24	3	18	37	38	15	M8
42/55	-	55	-	22	95	-	95	126	50	26	3	20	-	46	20	M8
48/60	-	60	-	30	105	-	105	140	56	28	3,5	21	-	51	20	M8

Order form

<p>Hub</p> <p>GRMP 48/60 AL F48</p> <p>GRMP: Standard TRASCO® hub GRMALU: TRASCO® aluminium hub</p> <p>Size</p> <p>A: execution A B: execution B AL: long execution A BL: long execution B</p> <p>F...: diameter of the bore</p>	<p>Spider</p> <p>AR 48/60 R</p> <p>TRASCO® spider</p> <p>Size</p> <p>92 Sh A (yellow) if not indicated R: 98 Sh A (red) V: 64 Sh D (green)</p>
---	---

Stock range

Hubs with finished bore H7, keyway (DIN 6885 sheet 1 - JS9), setscrew

Type	19/24		24/32			28/38			38/45			42/55			48/60			55/70	65/75	75/90	90/100		
Material*	ALU	AC	ALU	GG	GG	ALU	GG	GG	ALU	GG	GG	ALU	GG	GG	GG	GG	GG	GG	GG				
Hub execution	B	B	A	B	A	B	A	B	A	B	A	B	A	B	B	A	B	A	B	A	A	A	
Stock range bore [mm]	10	•	•																				
	11	•	•																				
	12	•	•																				
	14	•	•	•		•		•		•													
	15	•	•	•		•		•		•													
	16	•	•	•		•		•		•													
	18	•	•	•		•		•		•													
	19	•	•	•		•		•		•													
	20	•	•	•		•		•		•													
	22			•		•		•				•											
	24	•	•	•	•	•	•	•	•		•		•		•								
	25			•		•		•		•		•		•	•								
	28			•		•	•	•	•		•		•		•	•							
	30					•		•		•	•	•		•	•		•		•				
	32					•				•	•	•		•	•	•		•		•			
	35							•		•	•	•		•	•	•		•		•			
	38							•		•	•	•		•	•	•		•		•			
	40												•		•	•	•		•		•		
	42												•		•	•	•		•		•		
	45														•	•	•	•		•		•	•
48														•	•	•	•		•		•	•	
50														•	•	•	•		•		•	•	
55														•	•	•	•		•		•	•	
60															•	•	•		•		•	•	
65																•	•		•		•	•	
70																	•		•		•	•	
75																			•		•	•	
80																					•	•	
85																						•	
90																							•

*ALU = Aluminum - AC = Steel - GG = Cast iron

Setscrews types for single hubs

Hub dimension	P	t [mm]	Screw tightening torque [Nm]
19/24	M5	10	2
24/32	M5	10	2
28/38	M6	15	4,8
38/45	M8	15	10
42/55	M8	20	10
48/60	M8	20	10
55/70	M10	20	17
65/75	M10	20	17
75/90	M10	25	17
90/100	M12	30	40
100/110	M12	30	40
110/125	M16	35	80
125/145	M16	40	80
140/160	M20	45	140
160/185	M20	50	140
180/200	M20	50	140

