

Booster B-xxx4xx

Operating Instructions



RESISTRON / CIRUS temperature controllers can process very high peak and continuous primary currents as standard. External boosters (types B-075400, B-075415, and B-100400) can be supplied for higher currents.

! To prevent malfunctions, refer to the information provided in the latest version of the controller documentation and in the ROPEX Application Report if using a B-xxx4xx booster.

Technical data

	B-075400 (discontinued model)	B-075415 (successor model to B-075400)	B-100400
Type of construction	Booster with heat sink for installation in the electrical cabinet Snaps onto a top hat rail (DIN TS35 rail, 35mm) acc. to DIN EN 50022		
Size	Dimensions: 46 x 67mm Depth: 134mm (incl. cover)		Dimensions: 72 x 75mm Depth: 142mm (incl. cover)
Weight	Approx. 0.5kg		Approx. 1.1kg
Load current Terminals 1+2 (with heat sink)	75A peak current 25A continuous current		100A peak current 50A continuous current
Load voltage Terminals 1+2	110VAC - 15% ... 415VAC + 10% (94...456VAC)		
Control Terminals 3+4	RES-401/-402: RES-403/-407/-408: RES-406: RES-409: RES-415/-420/-440/-445: RES-5010/-5011/-5013: LPT-640: UPT-606: UPT-640: UPT-6010/-6011/-6013:	Not available With modification 26 (MOD 26) Standard, refer to controller documentation Up to January 2007: With modification 26 (MOD 26) As of February 2007: Standard, refer to controller documentation Standard, refer to controller documentation Standard, refer to controller documentation Standard, refer to controller documentation Standard, refer to controller documentation Standard, refer to controller documentation Standard, refer to controller documentation	

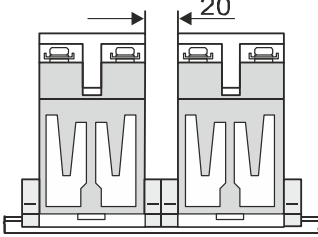
I²t (<10ms)	11,000A ² s	20,000A ² s
Degree of protection	IP00	
UL file	-	E471737
Installation	<p>A minimum safety clearance of 20mm all round (e.g. from other devices and wiring) must be allowed when installing the unit.</p> <p>The moving metal clip required for fastening must be facing down for mounting on a horizontal top hat rail.</p>  <p>! Adequate cooling is only guaranteed if the booster is mounted on a horizontal top hat rail which is fastened to a vertical mounting plate. If the booster is mounted in any other way, it could overheat and cause the equipment to malfunction.</p>	
Ambient conditions	<p>Max. altitude: 2000m Ambient temperature: +5...+45°C Max. relative humidity: 80% at temperatures up to 31°C, decreasing linearly to 50% relative humidity at +45°C</p>	
Connecting cable Type / cross-sections	<p><u>B-075400 / B-075415</u> Terminals 1+2 (load circuit): Screw terminals, diameter 4.1 mm M4 screw, PH2 screwdriver Tightening torque: 1.2...1.5Nm Terminals 3+4 (control): Screw terminals, diameter 3.5 mm M3 screw, PH1 screwdriver Tightening torque: 0.5...0.6Nm</p> <p><u>B-100400</u> Terminals 1+2 (load circuit): Screw terminals, diameter 5.2mm M5 screw, PH2 screwdriver Tightening torque: 2.5...4.5Nm Terminals 3+4 (control): Screw terminals, diameter 3.5 mm M3 screw, PH1 screwdriver Tightening torque: 0.5...0.6Nm</p> <p>! The cable which connects the RESISTRON / CIRUS temperature controller to the booster (terminals 3+4) must not be more than 1 meter long. Longer cables could cause the equipment to malfunction.</p>	
Power dissipation	Max. 40W	Max. 70W

Wiring diagram

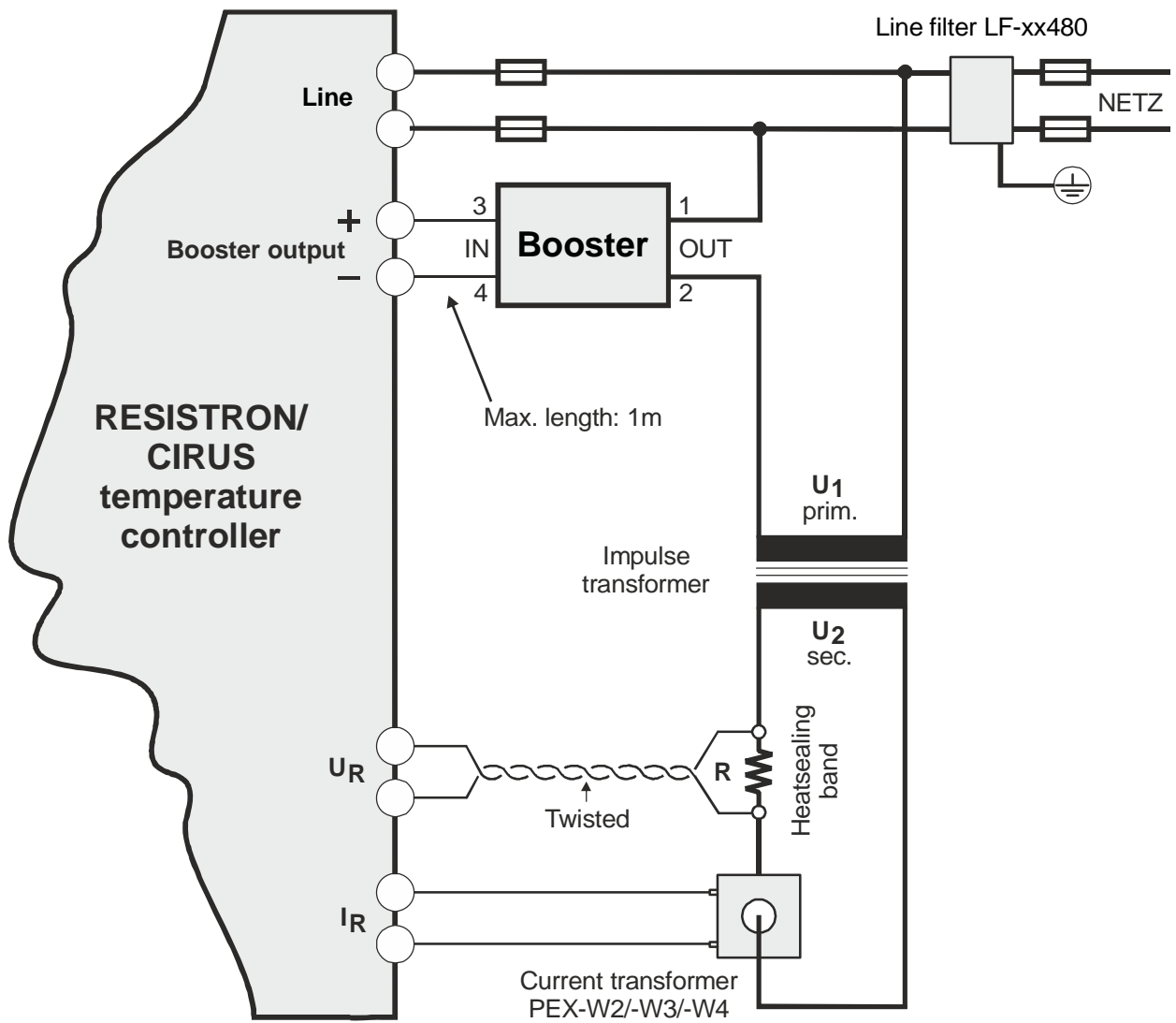

Dimensions

B-075400 / B-075415

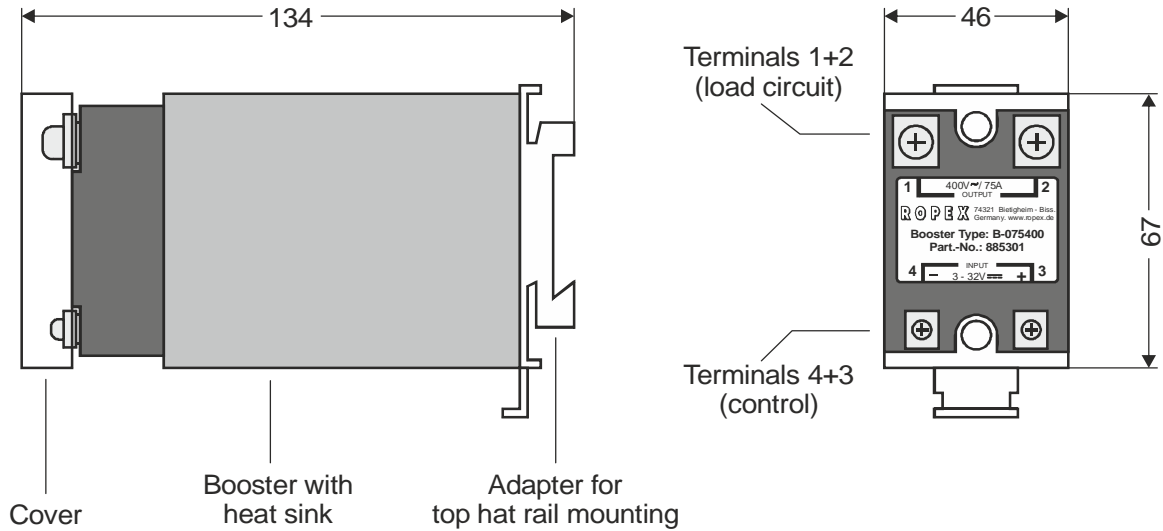

B-100400

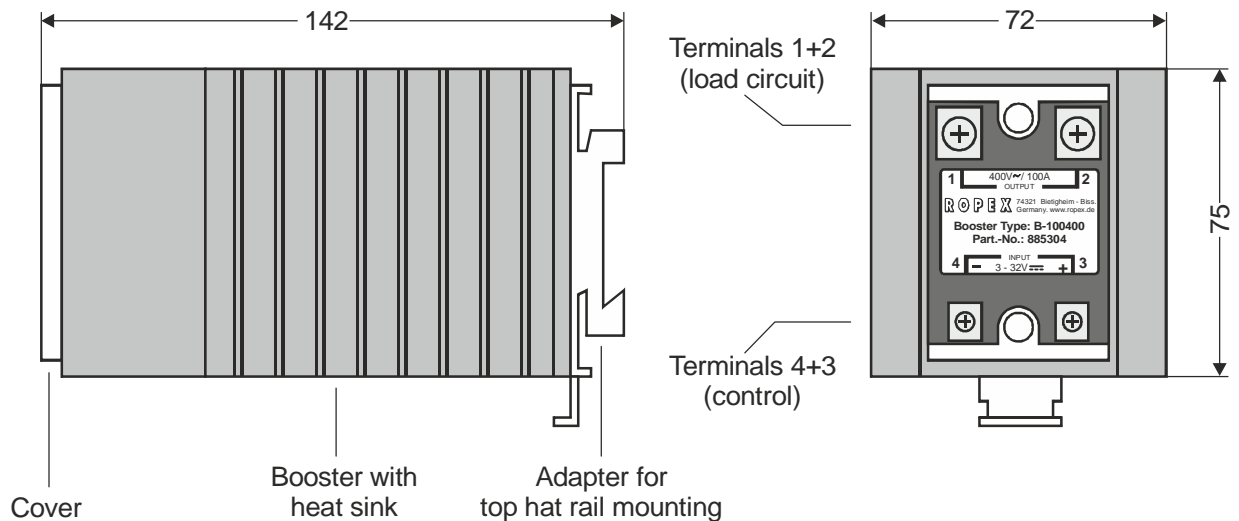

How to order



Booster

B-075400 (75A, 400VAC): Art. No. 885301 (discontinued model)

B-075415 (75A, 400VAC): Art. No. 885302 (successor model to B-075400)

B-100400 (100A, 400VAC): Art. No. 885304