

2,2 to 67 RPM
0,81 to 10 daN.m

BULK DIMENSIONS (BELOW WITH FASTENING N0)

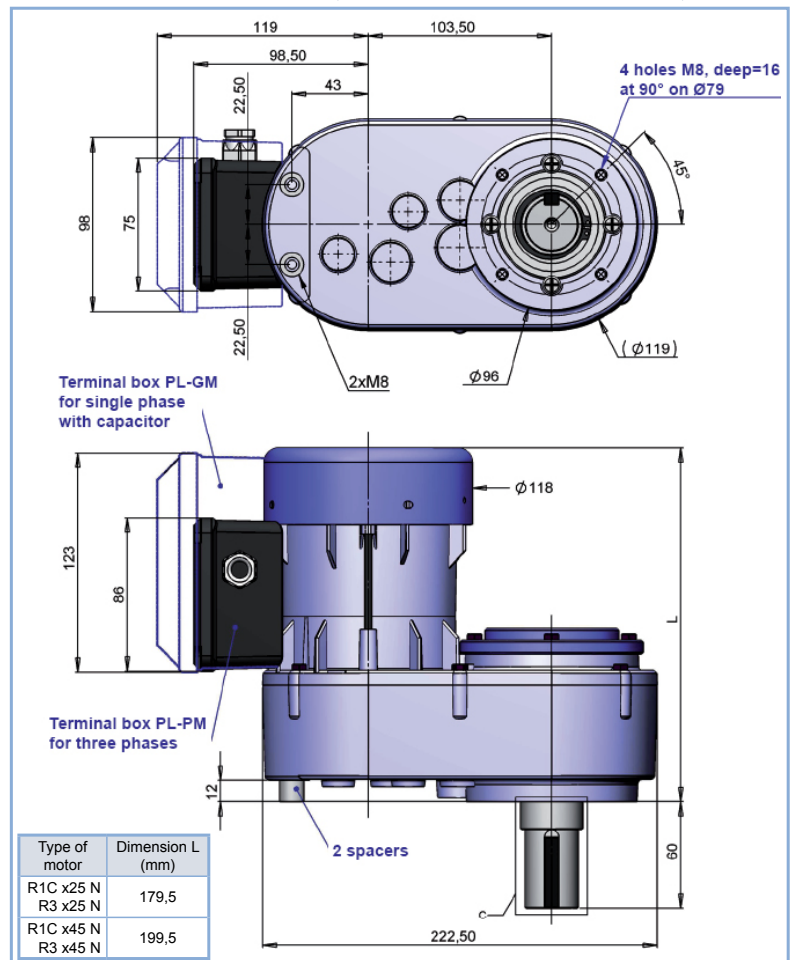

REVERSIBLE GEAR BOX WITH PARALLEL GEARS
MASSIVE OR HOLLOW SHAFT

APPLICATIONS :

- AUTOMATIC GATES
- ROLLING MACHINES
- RACK OVENS

TECHNICAL FEATURES :

- ASYNCHRONOUS MOTOR
- PERMANENTLY LUBRICATED
- THERMAL CUT OUT
- 2 DIRECTIONS OF ROTATION
- CLASS B INSULATION
- IP44 PROTECTION
- WORKING TEMPERATURE :
-20°C TO +85°C
- RELATIVE HYGROMETRY UNTIL 95%

OPTIONS AVAILABLE ON DEMAND :

- INRUSH OR LACK OF CURRENT BRAKE
(24 V OR 230 V WITH DIODE RECTIFIER)
WITH OR WITHOUT MANUAL UNLOCKING
- VOLTAGES AND FREQUENCIES ON REQUEST
- TORQUE MOTOR
- CLASS F INSULATION
- IP55 PROTECTION
- OUTPUT SHAFT ACCORDING TO SPECIFICATIONS

COMPLIES WITH STANDARDS :

- EN 60 335-1
- EN 60034-1
- CE

FASTENING N2

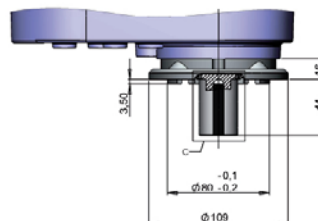
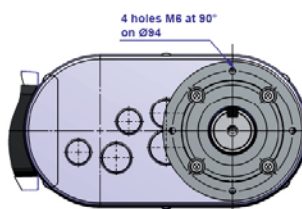

FASTENING N5

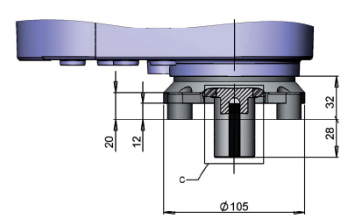
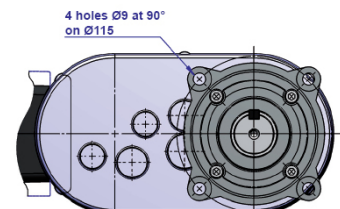

GEAR MOTOR DESIGNATION

R1C 245 N* B***

Additional designation	
B	product without additional designation
R	reinforced motor
F	means fitted with a brake

Mounting	
Gear type	Number of mounting
N	0 (hole on the front side) 2 (flange) 5 (flange)

Motor	
Number of poles	Stator size(mm)
2 or 4	25 or 45

Type of motor	
R1C	single phase motor with capacitor
R3	three phases motor

STANDARD MASSIVE SHAFT Hole tap M6 in option

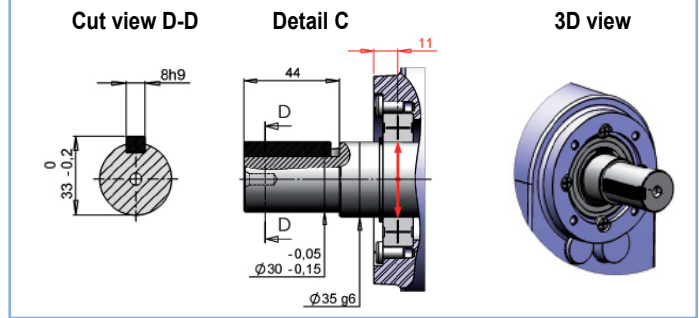

CHARACTERISTIC CURVE OF A SIREM ASYNCHRONOUS MOTOR

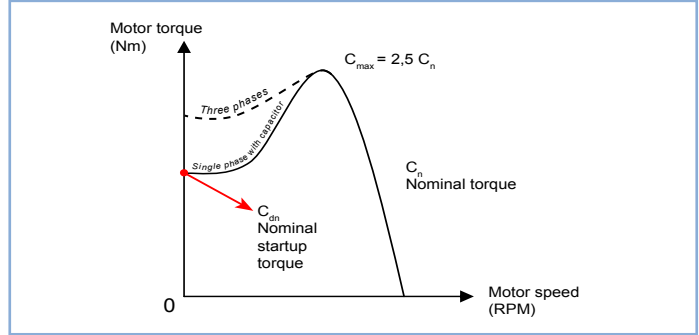

TECHNICAL FEATURES

Designation and Motor type	Gearbox						Motor									
	Gearbox speed (RPM)	Nominal torque (daNm)	Nominal startup torque (daNm)	Maximum radial load (daN)	Maximum axial load (daN)	Gearbox ratio	Output power (watts)	Motor torque (Ncm)	Motor speed (RPM)	Rated current under 230v (A)	I sin	Cd/Cn	Cos φ	Service class	Capacitor (µF)	Weight (kg)
Single phase motors																
R1C 425 N B	2.2	10	8.5	280	170	1/615	40	28.3	1350	0.55	1.34	0.85	0.99	S1	4	6.1
R1C 225 N B	4.5	7.4	7.6	267	160	1/615	51	17.1	2850	0.57	1.73	1.03	0.96	S1	5	6.1
R1C 245 N B	4.5	10	8.0	267	160	1/615	71	24.2	2800	0.59	2.3	0.8	0.99	S1	5	6.5
R1C 225 N B	5.1	6.5	6.7	255	158	1/548	51	17.1	2850	0.57	1.73	1.03	0.96	S1	5	6.1
R1C 245 N B	5.1	9	7.2	255	158	1/548	71	24.2	2800	0.59	2.3	0.8	0.99	S1	5	6.5
R1C 225 N B	6.5	5.1	5.3	234	155	1/429	51	17.1	2850	0.57	1.73	1.03	0.96	S1	5	6.1
R1C 245 N B	6.5	7	5.6	234	155	1/429	71	24.2	2800	0.59	2.3	0.8	0.99	S1	5	6.5
R1C 225 N B	7.3	4.6	4.7	220	150	1/383	51	17.1	2850	0.57	1.73	1.03	0.96	S1	5	6.1
R1C 245 N B	7.3	6.5	5.2	220	150	1/383	71	24.2	2800	0.59	2.3	0.8	0.99	S1	5	6.5
R1C 245 N B	9.5	5.1	4.1	208	140	1/303	71	24.2	2800	0.59	2.3	0.8	0.99	S1	5	6.5
R1C 245 N BR	9.5	10	4.9	208	240	1/126	145	51.2	2700	1.08	2.97	0.49	0.98	S1	8	6.5
R1C 445 N B	10.5	4	2.4	200	130	1/126	59	41.7	1350	0.53	1.53	0.61	0.99	S1	4	6.5
R1C 445 N BR	10.5	5.3	3.4	200	130	1/126	70	49.3	1350	0.69	1.51	0.65	0.99	S1	5	6.5
R1C 245 N B	14	3.4	2.7	184	120	1/200	71	24.2	2800	0.59	2.3	0.8	0.99	S1	5	6.5
R1C 245 N BR	14	7.2	3.5	184	120	1/200	145	51.2	2700	1.08	2.97	0.49	0.98	S1	8	6.5
R1C 245 N B	21	2.5	2.0	160	102	1/126	71	24.2	2800	0.59	2.3	0.8	0.99	S1	5	6.5
R1C 245 N BR	21	5.2	2.5	160	102	1/126	145	51.2	2700	1.08	2.97	0.49	0.98	S1	8	6.5
R1C 245 N B	25	2.2	1.8	150	93	1/112	71	24.2	2800	0.59	2.3	0.8	0.99	S1	5	6.5
R1C 245 N BR	25	4.6	2.3	150	93	1/112	145	51.2	2700	1.08	2.97	0.49	0.98	S1	8	6.5
R1C 245 N B	32	1.7	1.4	138	82	1/89	71	24.2	2800	0.59	2.3	0.8	0.99	S1	5	6.5
R1C 245 N BR	32	3.6	1.8	138	82	1/89	145	51.2	2700	1.08	2.97	0.49	0.98	S1	8	6.5
R1C 245 N B	48	1.2	1.0	122	69	1/59	71	24.2	2800	0.59	2.3	0.8	0.99	S1	5	6.5
R1C 245 N BR	48	2.4	1.2	122	69	1/59	145	51.2	2700	1.08	2.97	0.49	0.98	S1	8	6.5
R1C 245 N B	67	0.81	0.6	110	58	1/42	71	24.2	2800	0.59	2.3	0.8	0.99	S1	5	6.5
R1C 245 N BR	67	1.7	0.8	110	58	1/42	145	51.2	2700	1.08	2.97	0.49	0.98	S1	8	6.5
Three phases motors																
R3 425 N B	3.3	8	15.2	280	165	1/429	40	27.3	1400	0.41	2	1.9	0.65	S1	-	6.1
R3 225 N B	4.5	7.4	10.5	267	160	1/615	51	17.3	2800	0.37	2.97	1.42	0.7	S1	-	6.1
R3 245 N B	4.5	10	9.7	267	160	1/615	73	24.8	2800	0.42	3.25	0.97	0.79	S1	-	6.5
R3 225 N B	5.1	6.5	9.2	255	158	1/548	51	17.3	2800	0.37	2.97	1.42	0.7	S1	-	6.1
R3 245 N B	5.1	9	8.7	255	158	1/548	73	24.8	2800	0.42	3.25	0.97	0.79	S1	-	6.5
R3 225 N B	6.5	5.1	7.2	234	155	1/429	51	17.3	2800	0.37	2.97	1.42	0.7	S1	-	6.1
R3 245 N B	6.5	7	6.8	234	155	1/429	73	24.8	2800	0.42	3.25	0.97	0.79	S1	-	6.5
R3 225 N B	7.3	4.6	6.5	220	150	1/383	51	17.3	2800	0.37	2.97	1.42	0.7	S1	-	6.1
R3 245 N B	7.3	6.5	6.3	220	150	1/383	73	24.8	2800	0.42	3.25	0.97	0.79	S1	-	6.5
R3 245 N B	9.5	5.1	4.9	208	140	1/303	73	24.8	2800	0.42	3.25	0.97	0.79	S1	-	6.5
R3 245 N BR	9.5	10	8.9	208	240	1/126	145	51.2	2700	0.77	2.9	0.89	0.83	S1	-	6.5
R3 445 N B	10.5	4	5.7	200	130	1/126	50	35.3	1350	0.4	2.24	1.43	0.67	S1	-	6.5
R3 445 N BR	10.5	5.3	7.9	200	130	1/126	82	58	1350	0.61	2.24	1.49	0.71	S1	-	6.5
R3 245 N B	14	3.4	3.3	184	120	1/200	73	24.8	2800	0.42	3.25	0.97	0.79	S1	-	6.5
R3 245 N BR	14	7.2	6.4	184	120	1/200	145	51.2	2700	0.77	2.9	0.89	0.83	S1	-	6.5
R3 245 N B	21	2.5	2.4	160	102	1/126	73	24.8	2800	0.42	3.25	0.97	0.79	S1	-	6.5
R3 245 N BR	21	5.2	4.6	160	102	1/126	145	51.2	2700	0.77	2.9	0.89	0.83	S1	-	6.5
R3 245 N B	25	2.2	2.1	150	93	1/112	73	24.8	2800	0.42	3.25	0.97	0.79	S1	-	6.5
R3 245 N BR	25	4.6	4.1	150	93	1/112	145	51.2	2700	0.77	2.9	0.89	0.83	S1	-	6.5
R3 245 N B	32	1.7	1.6	138	82	1/89	73	24.8	2800	0.42	3.25	0.97	0.79	S1	-	6.5
R3 245 N BR	32	3.6	3.2	138	82	1/89	145	51.2	2700	0.77	2.9	0.89	0.83	S1	-	6.5
R3 245 N B	48	1.2	1.2	122	69	1/59	73	24.8	2800	0.42	3.25	0.97	0.79	S1	-	6.5
R3 245 N BR	48	2.4	2.1	122	69	1/59	145	51.2	2700	0.77	2.9	0.89	0.83	S1	-	6.5
R3 245 N B	67	0.81	0.8	110	58	1/42	73	24.8	2800	0.42	3.25	0.97	0.79	S1	-	6.5
R3 245 N BR	67	1.7	1.5	110	58	1/42	145	51.2	2700	0.77	2.9	0.89	0.83	S1	-	6.5

* : Applied on the bearings (see detail C on shaft)