

J78

Gas Pressure Regulator
Inlet Pressure 350mbar
Nominal Diameter 1/2", 3/4" & 1"

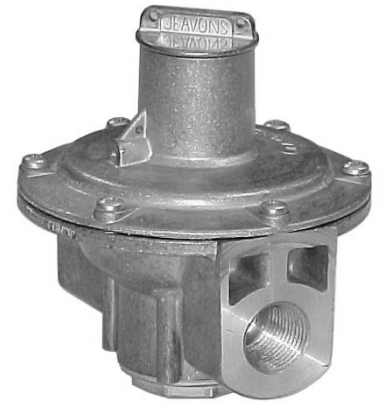

Applications

- Industrial
- Commercial

Brief information

Operation: The J78 range is a compact, accurate and economical regulator. It is suitable for a wide range of commercial and industrial applications, including such OEM equipment as boiler and burner trains. The J78 offers positive lock up, and is available in a number of sizes, with a comprehensive range of regulator springs for different requirements.

Application: The J78 is suitable for inlet pressures up to 350mbar (the J78R up to 100mbar under EN88). It meets the essential requirements of the European Gas Directive (2009/142/EC). All units are designed for natural, liquefied petroleum and manufactured gases and can be installed in horizontal or vertical pipelines. The regulators may be utilised for domestic meter service applications with inlet pressures up to 75mbar (30"wg) complying with British Gas specifications. High efficiency has been obtained by careful design of the internal gas ways. Thus ensuring maximum flow with minimum pressure loss.

Control: A comprehensive range of springs is available, as described overleaf. The outlet pressure can be easily and accurately adjusted by turning the spring adjustment unit located under the top cap. The cover and top cap are drilled so that a sealing wire can be easily fitted if required.

Options: The J78 range is available in two variants. The J78R has a plain breather port. The J78RS is fitted with a 1/4" threaded breather port that can be used to ventilate to atmosphere where this additional safety feature is required.

Approvals: The J78 range is approved to EN88-1 Class A2. The J78RS is also AGA / CGA approved to the following specifications:

CGA 6.3	- M95 / ANSI Z21.18 – 1995
CGA 6.3a	- M98 / ANSI Z21.18a – 1998
CGA 6.3b	- M100 / ANSI Z21.18b – 2000

Technical Data:

Maximum inlet pressure – J78RS:	350mbar (5 psig)
Maximum inlet pressure – J78R:	100mbar (1.43 psig)
Maximum outlet Pressure:	See table overleaf

Servicing: The J78 has been designed for ease of access, inspection and servicing of all internal components. A standard soft spares kit is available for all sizes.

1/2" & 3/4"	reference number SK7805-01
1"	reference number SK7806-01

Main features

- Sizes 1/2", 3/4" & 1"
- Temperature range
-20°C to +70°C
- Threaded connections to BS EN 10226 (ISO 7) or NPT (other threads may be available upon request)
- Fully inlet pressure balanced
- Full lock-up capability
- Internal impulse
- Spring loaded
- Excellent outlet pressure control

J78: Low Pressure Regulator

Regulating Capacities

All capacities in SCMH 0.64 s.g.

Setting Flow Rate: 1.4 SCMH

REGULATOR SIZE: 1/2"

OUTLET PRESSURE SETTING (mbar) / DROOP (%)

	10		17.5		20		27.5		50	
	10%	20%	10%	20%	10%	20%	10%	20%	10%	20%
Pin mbar										
15	3.5	4.6	-	-	-	-	-	-	-	-
20	4.8	6.0	4.0	5.1	-	-	-	-	-	-
25	5.6	7.0	4.8	6.8	4.4	6.3	-	-	-	-
35	7.1	9.3	5.3	7.4	5.4	8.0	6.3	7.5	-	-
53	7.3	8.8	5.8	8.4	6.1	8.1	7.0	11.3	8.0	10.4
70	4.4	5.9	6.3	8.8	6.5	8.4	9.4	13.1	8.2	12.5
105	4.2	5.6	7.8	9.1	7.8	9.6	9.6	11.6	8.4	15.6
140	4.1	5.5	7.0	8.8	7.1	9.4	10.0	11.2	9.0	18.1
210	3.4	5.4	6.4	8.4	6.6	9.1	8.5	10.8	8.8	19.4
350	8.8	10.1	7.4	12.5	8.1	14.0	10.4	20.0	10.0	21.3

REGULATOR SIZE: 3/4"

OUTLET PRESSURE SETTING (mbar) / DROOP (%)

Setting Flow Rate: 1.4 SCMH

	10		17.5		20		27.5		50	
	10%	20%	10%	20%	10%	20%	10%	20%	10%	20%
Pin mbar										
15	3.8	7.1	-	-	-	-	-	-	-	-
20	4.3	8.3	6.3	8.4	-	-	-	-	-	-
25	4.6	9.8	7.0	11.5	6.9	10.3	-	-	-	-
35	5.3	6.8	8.9	15.6	9.6	15.0	9.1	12.9	-	-
53	5.0	6.6	11.0	22.5	11.8	22.5	14.4	21.3	10.3	19.4
70	4.5	6.3	7.8	16.9	11.5	26.3	19.4	28.1	11.2	28.1
105	3.5	9.9	7.6	16.5	7.9	21.9	15.0	31.3	11.4	21.3
140	3.4	9.4	6.9	10.4	7.5	14.4	7.5	25.0	12.5	25.9
210	4.9	8.1	6.8	11.3	7.1	11.3	9.4	15.0	11.0	28.0
350	6.6	8.5	7.0	12.5	10.4	14.4	11.9	19.0	11.9	25.0

J78: Low Pressure Regulator

Regulating Capacities

All capacities in SCMH 0.64 s.g.

Setting Flow Rate: 1.4 SCMH

REGULATOR SIZE: 1"

OUTLET PRESSURE SETTING (mbar) / DROOP (%)

	10		17.5		20		27.5		50	
	10%	20%	10%	20%	10%	20%	10%	20%	10%	20%
Pin mbar										
15	5.0	8.1	-	-	-	-	-	-	-	-
20	6.0	9.5	7.3	12.9	-	-	-	-	-	-
25	6.8	10.9	10.0	16.3	9.4	17.5	-	-	-	-
35	7.3	13.0	15.9	21.3	15.0	22.5	12.1	25.0	-	-
53	7.4	18.8	24.4	27.5	21.3	27.5	21.3	33.8	21.3	35.0
70	22.5	25.0	27.5	30.0	25.0	32.5	27.5	41.3	30.6	45.0
105	16.3	27.5	30.0	37.5	26.3	37.5	30.0	53.8	50.0	53.8
140	26.3	33.8	31.3	32.5	30.0	36.3	50.0	61.3	56.3	61.3
210	30.0	35.0	38.8	41.3	38.8	41.3	47.5	65.0	66.3	70.0
350	3.4	5.1	6.8	12.5	5.6	9.3	6.8	12.8	9.6	41.3

The above tests are performed with the regulator set at a constant inlet pressure, a predetermined flow rate and the required outlet pressure. The flow rate is then increased whilst keeping the inlet pressure constant. The capacities are recorded when the outlet pressure has fallen by 10% and 20% from the set point.

The capacities on the previous pages are given in SCMH of natural gas (0.64 SG). For other gases multiply the capacity by:

$$\sqrt{\frac{0.64}{\text{gas sg}}}$$

GAS	SG
Air	1.00
Towns Gas	0.50
Propane	1.53
Propane / Air	1.20

J78: Low Pressure Regulator

Dimensions and Weights

SIZE	A		B		C		D		E		Weight (Kg)	
	R	RS	R	RS	R	RS	R	RS	R	RS	R	RS
½"	100	100	82	90	30	30	100	100	112	120	521g	543g
¾"	100	100	82	90	30	30	100	100	112	120	480g	502g
1"	100	100	82	90	40	40	105	105	122	130	534g	556g

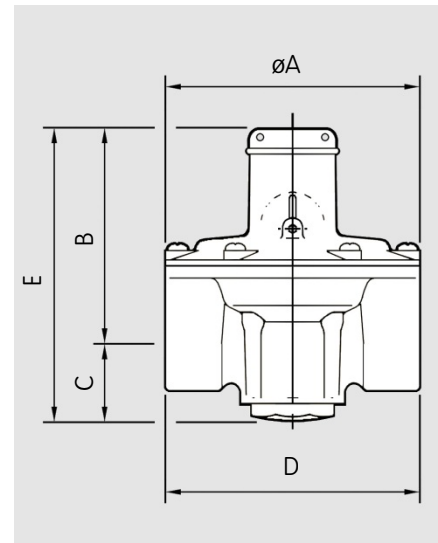

Material Specifications

A summary of the material specification for the J78 is given for reference. All material has been selected to provide maximum durability and reliability in service.

Components	Specification
Body, cover, bottom plug (1"), diaphragm spacer (1").	Aluminium Alloy
Top cap.	Zinc Alloy
Spring holder, valve spacer, diaphragm spacer (¾"), valve, valve disc holder (1"), valve spacer (1").	Acetal Resin
Diaphragm plate, secondary diaphragm clamping plate.	Mild Steel
Main diaphragm, secondary diaphragm, valve seat (¾"), valve disc (1") and "O"ring seals.	Nitrile (Buna)
Springs.	Carbon Steel
Impulse tube, bottom plug (¾").	Brass

Quality:

Elster Jeavons is committed to a programme of continuous quality enhancement. All equipment designed and manufactured by the Elster-Instromet group benefits from the group's quality assurance standards which are approved to EN ISO9001:2008.

Loading Springs

All springs are colour coded for ease of identification.

SPRING	Spring Range (mbar)				COLOUR CODE
	J78RS		J78R		
	½" - ¾"	1"	½" - ¾"	1"	
J7805-050	2 - 14	4 - 12	6 - 9	8.3 - 13	Dark Green / Red
J7805-038A	2 - 16	6 - 21	9 - 17	13 - 19	Yellow
J1105C-035A	10 - 20	13 - 26	15 - 23	20 - 24	Black
J1105C-016A	16 - 28	18 - 36	22 - 31	27 - 32	Orange
J7805-042A	22 - 40	28 - 48	31 - 42	37 - 46	Brown