

Compact design and high performance

Flexible Sub-base system

True multipressure system

Sandwich regulators and flow controls

Dual spool technology

V40 Glandless spool and sleeve

V41 Softseal spool

Collected pilot exhaust with internal pilot air supply

Easy to convert from internal to external pilot supply

Shut-off plate allows for exchange of valves under pressure



Technical data

Medium

Compressed air, 40µm filtered, lubricated or non-lubricated

Operation

V40: Glandless spool valve, solenoid pilot or air pilot actuated

V41: Softseal spool valve, solenoid pilot or air pilot actuated

Mounting

On sub-bases

Size

ISO 15407-1 / VDMA 24 563, 18 mm

Operating Pressure

Maximum pressure
 145 psig (10 bar) V41 models and V40 solenoid pilot actuated valves with internal pilot supply
 232 psig (16 bar) V40 solenoid pilot actuated valves with external pilot supply and V40 air pilot actuated valves

Flow Characteristics

Series	Function	Cv	l/min
V40	5/2	0.58	570
V40	5/3	0.62	610
V41*	2x3/2	1.62	610
V41*	5/2	0.66	650
V41*	5/3	0.69	680

Ambient Temperature

5°F* to 122°F (-15°C* to 50°C)

V40/V41 sol. and V41 air pilot models

5°F* to 176°F (-15°C* to 80°C) V40 air pilot models

*Consult our Application Engineering for use below 36°F (2°C)

Materials

Die cast aluminum body and sub-base. Hard anodized spool, PTFE coated, matched aluminum spool and sleeve (V40) or aluminum alloy spool with HNBR Seals (V41). POM plastic parts and NBR static seals. End cover and screws zinc plated, stainless steel springs.

Electrical Details for Solenoid Pilot

Voltage Tolerances	-10% / +15%
Rating	100% Continuous Duty
Inlet orifice	0.8 mm
Electrical Connection	DIN 43 650 table 'C'
Manual Override	Push and turn locking and non-locking
Protection Class	IP 65 NEMA 4
Materials	PPS (body), FPM and NBR (seals)

2x3/2 Solenoid Pilot Actuated Valves (Softseal Spool only)

	Model	Function 2x3/2	Pilot Supply	Pilot Exhaust	Actuation 3/2 Function	Flow Cv	Operating Pres. psig	Pilot Pres. (psig)	Weight lb.	Repair Kit
	V415A11D-C3**†	NC	Internal	Collected	Sol/Spring	0.62	36 - 145	-	0.40	V70447-K50
	V415A22D-C3**†	NC	External	Not Collected	Sol/Spring	0.62	0 - 145	24.7+(0.35 x op.press.)	0.40	V70447-K50
	V415B11D-C3**†	NO	Internal	Collected	Sol/Spring	0.62	36 - 145	-	0.40	V70448-K50
	V415B22D-C3**†	NO	External	Not Collected	Sol/Spring	0.62	0 - 145	24.7+(0.35 x op.press.)	0.40	V70448-K50
	V415C11D-C3**†	NO/NC	Internal	Collected	Sol/Spring	0.62	36 - 145	-	0.40	V70449-K50
	V415C22D-C3**†	NO/NC	External	Not collected	Sol/Spring	0.62	0 - 145	24.7+(0.35 x op.press.)	0.40	V70449-K50

NC = Normally Closed NO = Normally Open

5/2 Solenoid Pilot Actuated Valves

	Model	Spool Techn.	Pilot Supply	Pilot Exhaust	Operator 14	Return 12	Flow Cv	Operating Pres. (psig)	Pilot Pres. (psig)	Weight lb.	Repair Kit
	V405513D-C3**†	Gl	Internal	Collected	Solenoid	Air Spring	0.58	14.5 - 145	-	0.26	V70440-K50
	V415513D-C3**†	Ss	Internal	Collected	Solenoid	Air Spring	0.66	14.5 - 145	-	0.29	V70442-K50
	V405523D-C3**†	Gl	External	Not collected	Solenoid	Air Spring	0.58	26" Hg - 232	14.5 - 145	0.26	V70440-K50
	V415523D-C3**†	Ss	External	Not collected	Solenoid	Air Spring	0.66	26" Hg - 145	14.5 - 145	0.29	V70442-K50
	V405516D-C3**†	Gl	Internal	Collected	Solenoid	Spring & air	0.58	23.2 - 145	-	0.29	V70440-K50
	V415517D-C3**†	Ss	Internal	Collected	Solenoid	Spring	0.66	29 - 145	-	0.29	V70442-K50
	V405526D-C3**†	Gl	External	Not collected	Solenoid	Spring & air	0.58	26" Hg - 232	23.2 - 145	0.29	V70440-K50
	V415527D-C3**†	Ss	External	Not collected	Solenoid	Spring	0.66	26" Hg - 145	29 - 145	0.29	V70442-K50
	V405511D-C3**†	Gl	Internal	Collected	Solenoid	Solenoid	0.58	29 - 145	-	0.40	V70441-K50
	V415511D-C3**†	Ss	Internal	Collected	Solenoid	Solenoid	0.66	29 - 145	-	0.40	V70443-K50
	V405522D-C3**†	Gl	External	Not collected	Solenoid	Solenoid	0.58	26" Hg - 232	29 - 145	0.40	V70441-K50
	V415522D-C3**†	Ss	External	Not collected	Solenoid	Solenoid	0.66	26" Hg - 145	29 - 145	0.40	V70443-K50
	V405591D-C3**†	Gl	Internal	Collected	Solenoid (priority)	Solenoid	0.58	29 - 145	-	0.40	V70441-K50
	V405592D-C3**†	Gl	External	Not collected	Solenoid (priority)	Solenoid	0.58	26" Hg - 232	29 - 145	0.40	V70441-K50

** Insert voltage code from Table 1 "Voltage Codes and Spare Pilot Valves".
† Add connector code from Table 2 "Connector Codes and Part Number".
Gl = Glandless Spool Ss = Soft Seal

Table 1
**Voltage Codes and Spare Pilot Valves

Voltage	Code	Power Inrush / Hold	Pilot Valve Part. -no.	
			Push only	Push and Turn
12 VDC	12	1.2 W	VZC7L2C1-C312A	
24 VDC	13	1.2 W	VZC7L2C1-C313A	VZC7L2C1-C213A
24 V 50/60 Hz.	14	2.1 / 1.5 VA	VZC7L2C1-C314A	
48 V 50/60 Hz	16	2.1 / 1.5 VA	VZC7L2C1-C316A	
110 VDC	17	1 W	VZC7L2C1-C317A	
115 V 50/60 Hz	18	2.1 / 1.5 VA	VZC7L2C1-C318A	VZC7L2C1-C218A
230 V 50/60 Hz	19	2.1 / 1.5 VA	VZC7L2C1-C319A	

Other voltages available on request.
Spare pilot valves are delivered with mounting screws.

Table 2
†Connector Codes and Part Number

Code	Part Number
A = Solenoid without connector	
B = Cable grip	V10027-D00
C = 10 ft. molded cable, 0-240 VAC/VDC	V10013-D03
H = Cable grip w/indicator light, 24 VAC/VDC	V10012-D13
J = Cable grip w/indicator light, 120 VAC/VDC	V10012-D18
5 = 10 ft. molded cable with indicator light, surge suppression, 24 VAC/VDC	V10014-D03
6 = 10 ft. molded cable with indicator light, 110V/50 Hz-120V.60Hz	V10015-D03

5/3 Solenoid Pilot Actuated Valves

	Model	Spool Techn.	Valve Function	Pilot Supply	Pilot Exhaust	Operator 14	Return 12	Flow Cv	Operating Pres. (psig)	Pilot Pres. (psig)	Weight lb.	Repair Kit
	V405611D-C3**†	GI	APB	Internal	Collected	Solenoid	Solenoid	0.62	29 - 145	-	0.40	V70441-K50
	V415611D-C3**†	Ss	APB	Internal	Collected	Solenoid	Solenoid	0.69	29 - 145	-	0.40	V70444-K50
	V405622D-C3**†	GI	APB	External	Not collected	Solenoid	Solenoid	0.62	26" Hg - 232	29 - 145	0.40	V70441-K50
	V415622D-C3**†	Ss	APB	External	Not collected	Solenoid	Solenoid	0.69	26" Hg - 145	29 - 145	0.40	V70444-K50
	V405711D-C3**†	GI	COE	Internal	Collected	Solenoid	Solenoid	0.62	29 - 145	-	0.40	V70441-K50
	V415711D-C**†	Ss	COE	Internal	Collected	Solenoid	Solenoid	0.69	29 - 145	-	0.40	V70441-K50
	V405722D-C3**†	GI	COE	External	Not collected	Solenoid	Solenoid	0.62	26" Hg - 232	29 - 145	0.40	V70441-K50
	V415722D-C3**†	Ss	COE	External	Not collected	Solenoid	Solenoid	0.69	26" Hg - 145	29 - 145	0.40	V70445-K50
	V405811D-C3**†	GI	COP	Internal	Collected	Solenoid	Solenoid	0.62	29 - 145	-	0.40	V70441-K50
	V415811D-C3**†	Ss	COP	Internal	Collected	Solenoid	Solenoid	0.69	29 - 145	-	0.40	V70446-K50
	V404822D-C3**†	GI	COP	External	Not collected	Solenoid	Solenoid	0.62	26" Hg - 232	29 - 145	0.40	V70441-K50
	V415822D-C3**†	Ss	COP	External	Not collected	Solenoid	Solenoid	0.69	26" Hg - 145	29 - 145	0.40	V70446-K50

** Insert voltage code from Table 1 "Voltage Codes and Spare Pilot Valves".
† Add connector code from Table 2 "Connector Codes and Part Number".

GI = Glandless Spool
Ss = Soft Seal

APB = All Ports Blocked
COE = Center Open to Exhaust
COP = Center Open to Pressure

Table 1
**Voltage Codes and Spare Pilot Valves

Voltage	Code	Power Inrush / Hold	Pilot Valve Part.-no. Push only	Push and Turn
12 VDC	12	1.2 W	VZC7L2C1-C312A	
24 VDC	13	1.2 W	VZC7L2C1-C313A	VZC7L2C1-C213A
24 V 50/60 Hz.	14	2.1 / 1.5 VA	VZC7L2C1-C314A	
48 V 50/60 Hz	16	2.1 / 1.5 VA	VZC7L2C1-C316A	
110 VDC	17	1 W	VZC7L2C1-C317A	
115 V 50/60 Hz	18	2.1 / 1.5 VA	VZC7L2C1-C318A	VZC7L2C1-C218A
230 V 50/60 Hz	19	2.1 / 1.5 VA	VZC7L2C1-C319A	

Other voltages available on request.
Spare pilot valves are delivered with mounting screws.

NC = Normally Closed NO = Normally Open

2x3/2 Air Pilot Actuated Valves (Softseal Spool)

Model	Function 2x3/2	Actuation 3/2 Function	Flow Cv	Operating Pres. (psig)	Pilot Pres. (psig)	Weight (lb.)	Spares Kit
V415A33A-X0020	NC	Air/Spring	0.62	0 - 145	24.7 + (0.35 x op. pressure)	0.26	V70447-K50
V415B33A-X0020	NO	Air/Spring	0.62	0 - 145	24.7 + (0.35 x op. pressure)	0.26	V70448-K50
V415C33A-X0020	NO/NC	Air/Spring	0.62	0 - 145	24.7 + (0.35 x op. pressure)	0.26	V70449-K50

5/2 Air Pilot Actuated Valves

Model	Spool Techn.	Operator 14	Return 12	Flow Cv	Operating Pres. (psig)	Pilot Pres. (psig)	Weight (lb.)	Repair Kit
	V405537A-X0090	GI	Air	Spring	0.58	26" Hg - 232	23.2 - 232	V70440-K50
	V415537A-X0090	Ss	Air	Spring	0.66	26" Hg - 145	29 - 145	V70442-K50
	V405533A-X0020	GI	Air	Air	0.58	26" Hg - 232	29 - 232	V70441-K50
	V415533A-X0020	Ss	Air	Air	0.66	26" Hg - 145	29 - 145	V70443-K50
V405533A-X0020	GI	Air (priority)	Air	0.58	26" Hg - 232	29 - 232	V70441-K50	

GI = Glandless Spool Ss = Soft Seal

5/3 Air Pilot Actuated Valves

	Model	Spool	Valve Function	Operator 14	Return 12	Flow Cv	Operating Pres. (psig)	Pilot Pres. (psig)	Weight (lb.)	Spares Kit
	V405633A-X0020	GI	APB	Air	Air	0.62	26" Hg - 232	29 - 232	0.24	V70441-K50
	V415633A-X0020	Ss	APB	Air	Air	0.69	26" Hg - 145	36 - 145	0.26	V70444-K50
	V405733A-X0020	GI	COE	Air	Air	0.62	26" Hg - 232	29 - 232	0.24	V70441-K50
	V415733A-X0020	Ss	COE	Air	Air	0.69	26" Hg - 145	36 - 145	0.26	V70445-K50
	V405833A-X0020	GI	COP	Air	Air	0.62	26" Hg - 232	29 - 232	0.24	V70441-K50
	V415833A-X0020	Ss	COP	Air	Air	0.69	26" Hg - 145	36 - 145	0.26	V70446-K50

GI = Glandless Spool
Ss = Soft Seal

APB = All Ports Blocked
COE = Center Open to Exhaust
COP = Center Open to Pressure

Bases

Single Station Sub-base Ported w/o Pilot Ports	Modular Sub-base Side Ported w/o Pilot Ports	Modular Sub-base Side* Ported with Pilot Ports	Modular Sub-base Side Ported (PIF) w/o Pilot Ports	Modular Sub-base Side* Ported (PIF) with Pilot Ports
V70401-P5B (1/8 NPTF)	V70425-P5F (1/8 NPTF)	V70426-P5F (1/8 NPTF)	V70425-15F (ø1/4")	V70426-15F (ø1/4")
V70401-A5B (G1/8)	V70425-A5F (G1/8)	V70426-A5F (G1/8)	V70425-85F (ø8 mm)	V70426-85F (ø8 mm)
			V70425-65F (ø6 mm)	V70426-65F (ø6 mm)

*Use with air pilot valves

*Use with air pilot valves

End Plate Kit End Ported	Double Station Modular Sub-base Side Ported without Pilot Ports	End Plate Kit with 2 Side Ported Valve Stations without Pilot Ports	Intermediate Supply/Exhaust Module	Single Valve Shut-Off Plate
V70424-R5C (1/4 NPTF)	V70432-P5F (1/8 NPTF)	V70431-P5F (1/4, 1/8 NPTF)	V70429-P50 (1/8 NPTF)	V70430-K50 (Port 1 open/closed)
V70424-B5C (G1/4)	V70432-A5F (G1/8")	V70431-A5F (G1/4, G1/8)	V70429-A50 (G1/8)	

Sandwich Plate with additional Pressure Port 1	Single Pressure Regulator Plate	Double Pressure Regulator Plate	Flow Control Plate	Blanking Plate for unused Station
V70435-P50 (1/8 NPTF)	V70427-K51 (Port 1 reg.)	V70427-K54 (Ports 2+4 reg.)	V70428-K50 (Ports 3+5 reg.)	V70400-K50
	V70427-K52 (Port 2 reg.)			
	V70427-K53 (Port 4 reg.)			

DIN EN 50 022 rail (1 metre)	DIN-rail Mounting Kit	Single Blanking Disk to Modular Sub-base	Manual Override Set-Up Kit	Transition Plate #18 mm - #26 mm
V10009-C00 (35x7.5mm)	V70531-KA0	V70422-K50 (1 each) (Ports 1,3,5)	V70532-K00	V70436-K00
V10592-C01 (35x15mm)		V70423-K50 (1 each) (Ports 12+14)		

V4055*3D-C3* and V4155*3D-C3***
Models 5/2 Single Solenoid Pilot Valve
Air Spring Return**

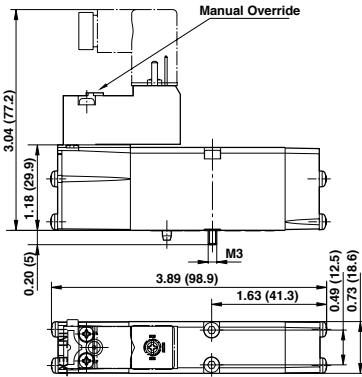

V4055*6D-C3* and V4155*7D-C3*** Mo-
dels 5/2 Single Solenoid Pilot Valve
Mechanical (& Air) Spring Return**

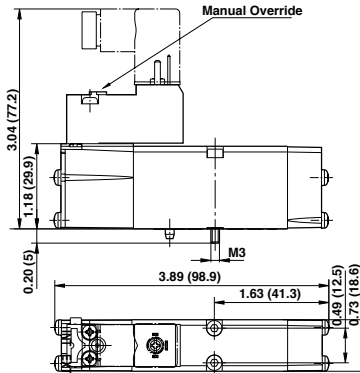

V4055D-C3*** and V4155**D-C3***
Models 5/2 Double Solenoid Pilot Valve**

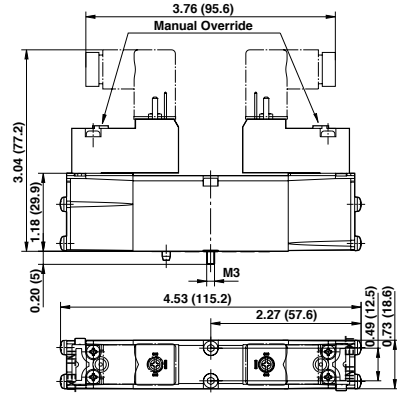

V405*D-C3*** and
V415***D-C3*** Models
2x3/2 + 5/3 Double Solenoid Pilot Valve**

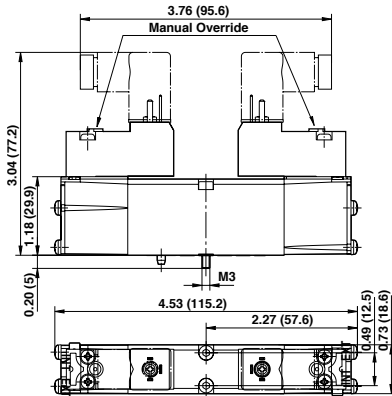

**V415537A-X0090
5/2 Single Air Pilot Valve**

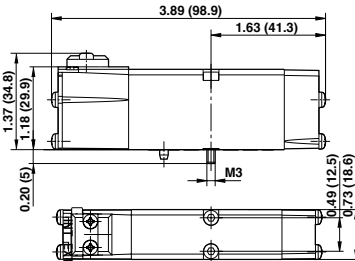

**V405537A-X0090 5/2 Single Air Pilot Valve
V405*33A-X00*0 and
V415*33A-X00*0 Models
2x3/2, 5/2 + 5/3 Double Air Pilot Valve**

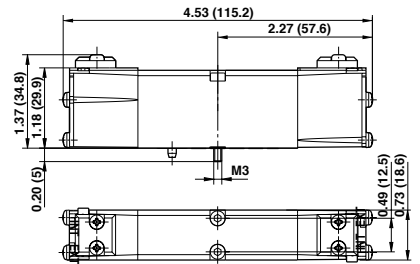

Conversion from internal to external pilot supply / Collected pilot exhaust

The lowered and captive gasket between valve body and pilot valve defines and indicates pilot air supply as well as pilot exhaust function of the valve.

Solenoid pilot actuated valves

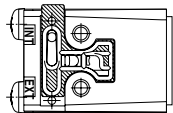

blue gasket

Drawing shows no pilot valve.

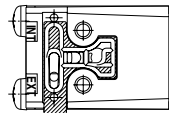

blue gasket

**Internal pilot supply,
pilot exhaust air collected and exhausted via port 14.**

All solenoid pilot valves with code 1 at position 6 in the part number (e.g V41551to) have the gasket mounted in this position on delivery.

**External pilot supply from port 14 only, pilot exhaust air not collected
but bleed through valve body.**

All solenoid pilot valves with code 2 at position 6 in the part number (e.g V41552to) have the gasket mounted in this position on delivery.

Note: Dismounting pilot valve gives access to gasket. Conversion from internal to external pilot supply (or vice versa) by turning the gasket. Caution: In this case part number and symbol on label shows different function. Therefore check gasket position when mounting valve.

Air pilot actuated valves

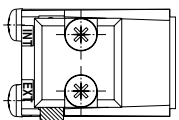

blue gasket

Drawing includes cover plate.

5/2 Solenoid pilot actuated valves with air spring return
Drawing shows end cap side 12.

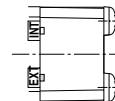
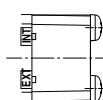

Air pilot actuated valves

External pilot supply.

Dimensions in inches (mm)

**Modular Subbases parts for
 DIN rail or surface mounting**

Subbase

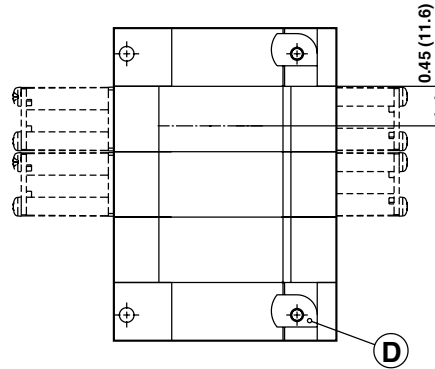

Side ported subbase

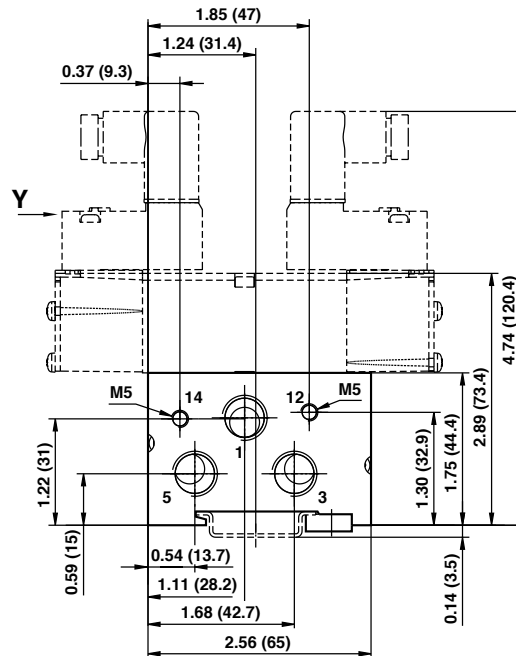
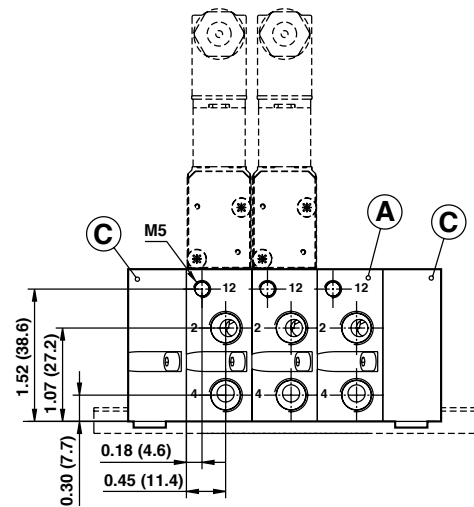

Side ported sub-base

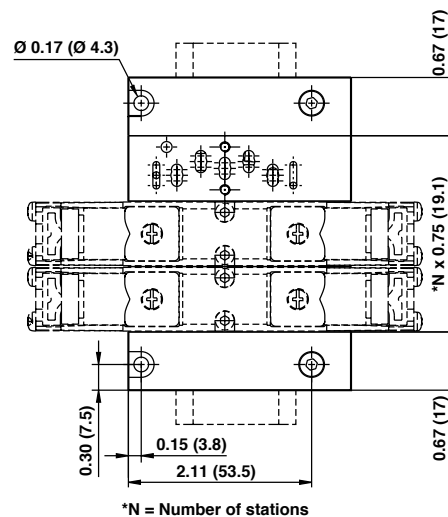
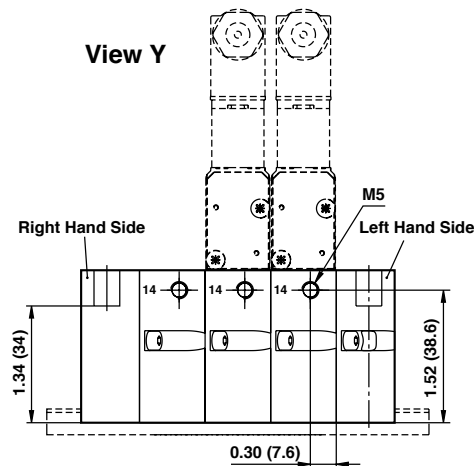

Note:
 Port 14 either used for external pilot air supply or for collected pilot air exhaust.
Therefore, never plug port 14 when using valves with internal pilot air supply.
 Port 12 is not used, plugging not necessary.

Individual components

- Modular Subbase (A) 0.26 lb (0.12 kg)
V70425-x5F
- Double Station Modular Subbase 0.53 lb (0.24 kg)
V70432-y5F
- Modular Subbase (A) 0.26 lb (0.12 kg)
 Ports 2+4 on side
V70426-x5F
- End Plate Kit (C) 0.46 lb (0.21 kg)
V70424-B5C (G1/4)
V70424-R5C (1/4NPTF)
 End ported end caps
 1 left hand and 1 right hand
- End Plate Kit with Valve Station
 Ports 2+4 on side 0.88 lb (0.4 kg)
V70431-A5F (1/3/5 G1/4, 2/4 G1/8)
V70431-P5F (1/3/5 1/4NPTF, 2/4 1/8NPTF)
 End ported end caps
 1 left hand and 1 right hand

Accessories

- DIN EN 50022 rail 35 x 7.5 mm, 1m 0.68 lb (0.31 kg)
V10009-C00
- DIN EN 50022 rail 35 x 15 mm, 1m 2.25 lb (1.02 kg)
V10592-C01
- DIN rail (D) 0.02 lb (0.01 kg)
 Mounting Kit
V70531-KAO
- Blanking Disk to Modular Subbase
 Ports 1, 3, 5 0.02 lb (0.01 kg)
V70422-K50
- Blanking Disk to Modular Subbase
 Ports 12+14 0.02 lb (0.01 kg)
V70423-K50

x/y = Insert port type from table below

Code x	Code y	Ports 2+4	Ports 12+14
A	A	G1/8	M5
P	P	1/8 NPTF	M5
8	-	Ø 8 mm PIF	M5
6	-	Ø 6 mm PIF	M5
1	-	Ø 1/4" PIF	M5

Dimensions in inches (mm)

Single Station Subbase - Side Ported with Pilot Ports

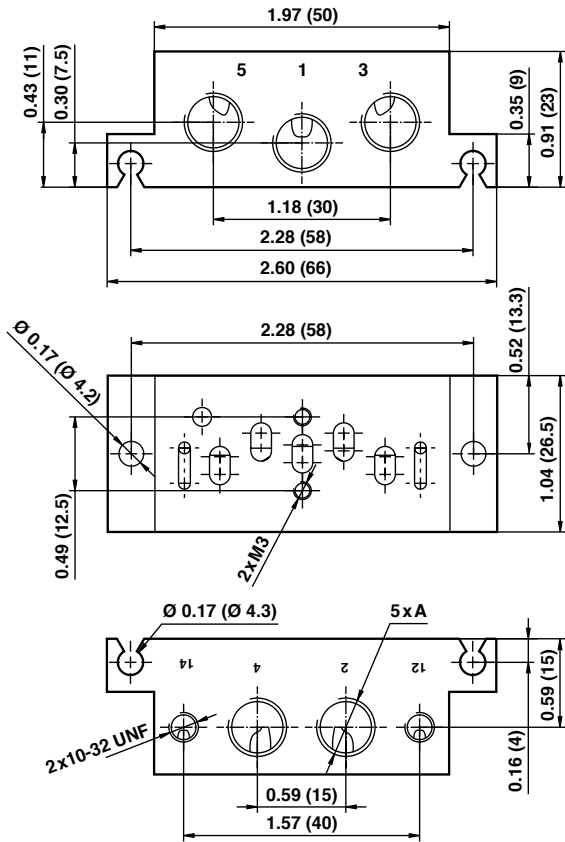

Dimensions in inches (mm)

Model	Port Size A	Weight lb (kg)
V70401-P5B	1/8NPTF Side Ported with Pilot Ports	0.18
V70401-A5B	G1/8 Side Ported with Pilot Ports	(0.08)

Note: Pilot Ports for both types = 10-32 UNF

Intermediate Supply / Exhaust Module

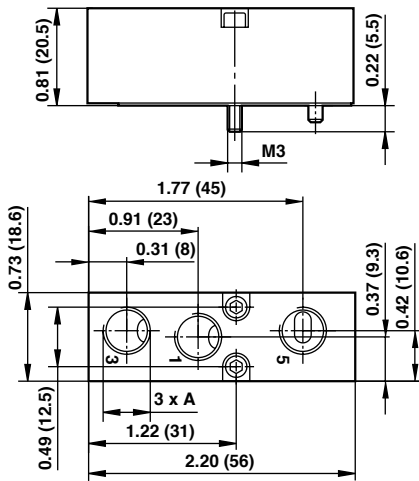

Model	Port Size A	Weight lb (kg)
V70429-P50	1/8NPTF	0.11
V70429-A50	G1/8	(0.05)

Provides additional porting on Modular- or Fixed Length Sub-base.
 Occupies one valve station.
 Supplied with gasket for both sub-bases.

Can be used to:

- Improve supply flow
- Increase exhaust capacity
- Pneumatically separate valves for fail save emergency
- Multipressure system and system solutions

Single Valve Shut-Off Plate

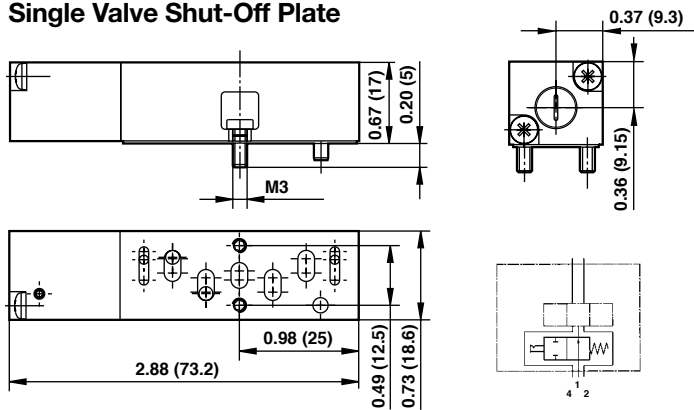

Model	Description	Weight lb (kg)
V70430-K50	Single Shut-Off Plate supplied with gasket	0.13 (0.06)

Allows individual exchange of valve, while valve manifold is pressurized by port 1.

Note: Flow restricted to maximum .24 Cv

Sandwich Flow Control

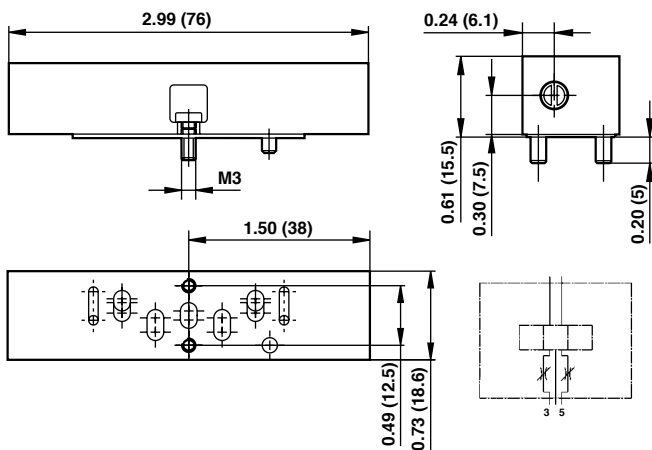

Model	Description	Weight lb (kg)
V70428-K50	Flow Control supplied with gasket	0.13 (0.06)

Dual Regulation of Exhaust Ports 3 and 5

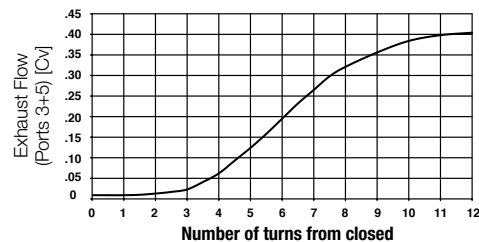

Flow: Port 1 → 2 and 1 → 4: remains unchanged
 Flow measured at 6 bar inlet, Pressure drop 1 bar

Dimensions in inches (mm)

Blanking Plate

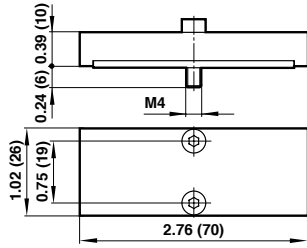

Model	Description	Weight lb (kg)
V70400-K50	Blanking Plate for blocking of unused Stations (supplied with gasket)	0.04 (0.02)

Pressure Regulator Plates (including gauge and adapter tube)

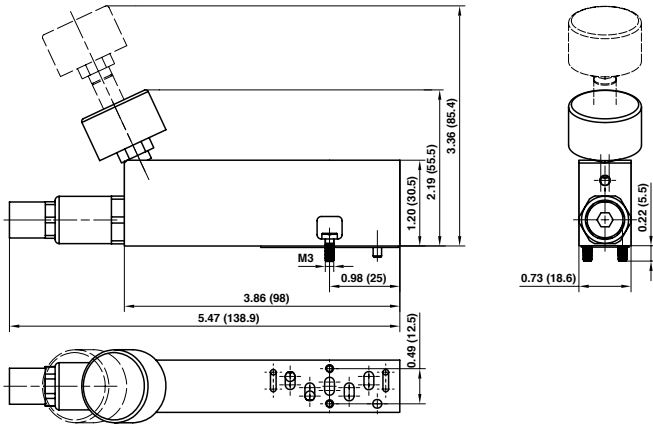

Model	Description	Weight lb (kg)
V70427-K51	Regulation of Port 1	0.46 (0.21)

Maximum inlet pressure 232 psig (16 bar)
Regulated pressure 14.5–145 psig (1–10 bar)

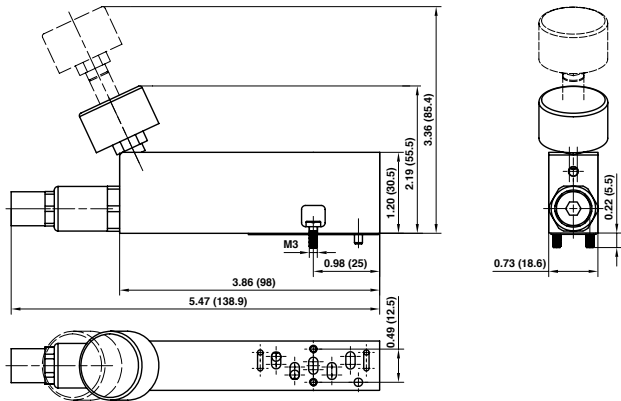
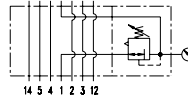

Model	Description	Weight lb (kg)
V70427-K52	Regulation of Port 2	0.46 (0.21)

Maximum inlet pressure 232 psig (16 bar)
Regulated pressure 14.5–145 psig (1–10 bar)

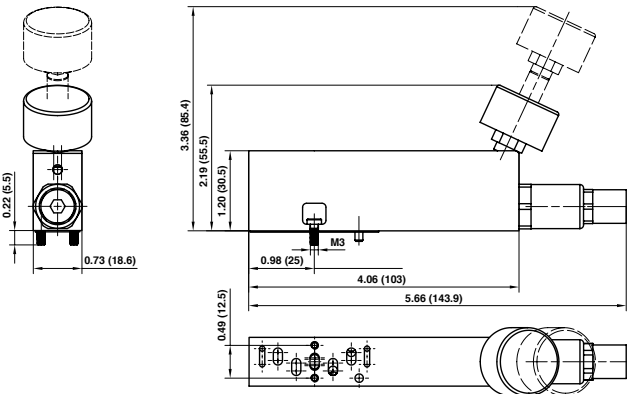
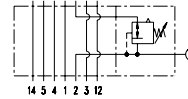

Model	Description	Weight lb (kg)
V70427-K53	Regulation of Port 4	0.46 (0.21)

Maximum inlet pressure 232 psig (16 bar)
Regulated pressure 14.5–145 psig (1–10 bar)

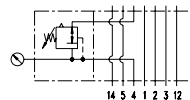

Dimensions in inches (mm)

Dual regulator

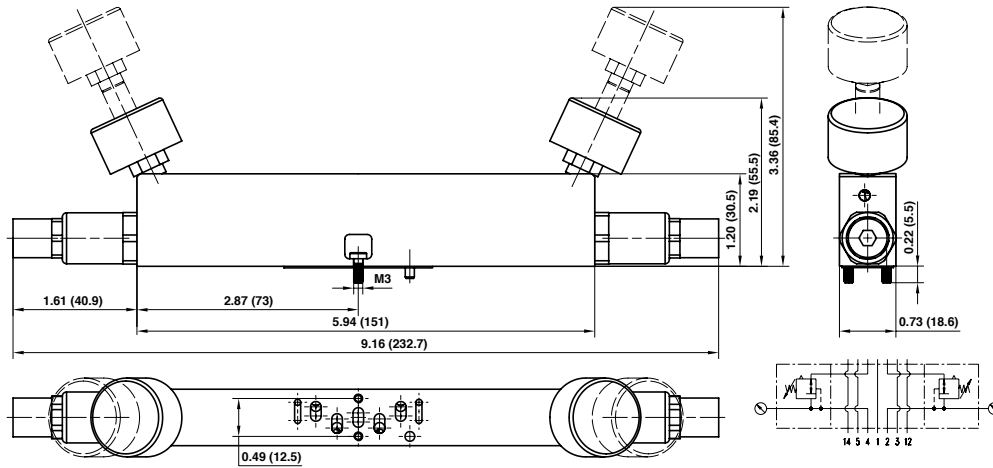

Model	Description	Weight lb (kg)
V70427-K54	Regulation of Ports 2+4	0.79 (0.36)

Maximum inlet pressure (16 bar) 232 psig
 Regulated pressure 14.5–145 psig (1–10 bar)

Flow Characteristics for
 Pressure Regulator Plates

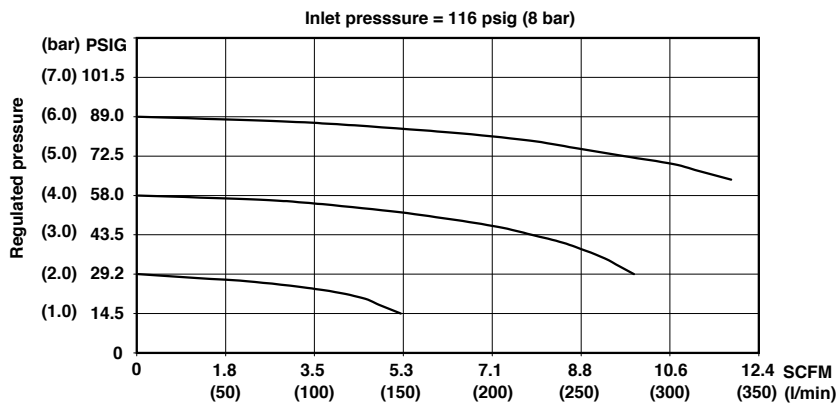

Dimensions in inches (mm)

Model	Description	Weight lb (kg)
V70435-P50	Sandwich Plate with additional Port 1, supplied with gasket	0.09 (0.04)

Sandwich Plate with additional Pressure Port 1

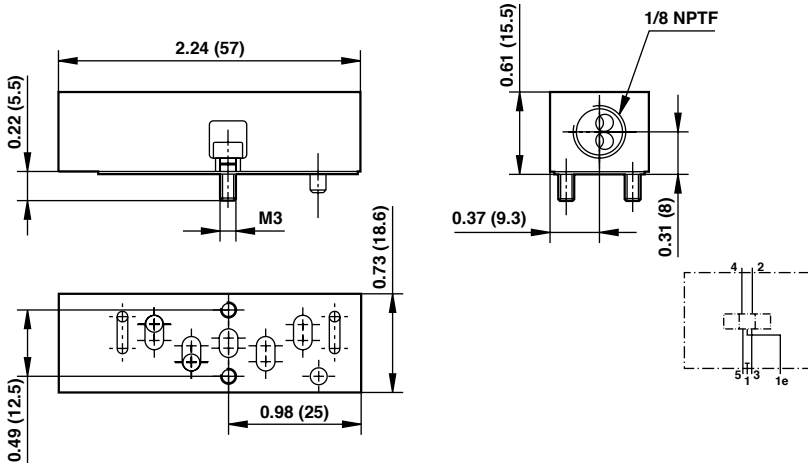

Transition Plate #18 mm to #26 mm

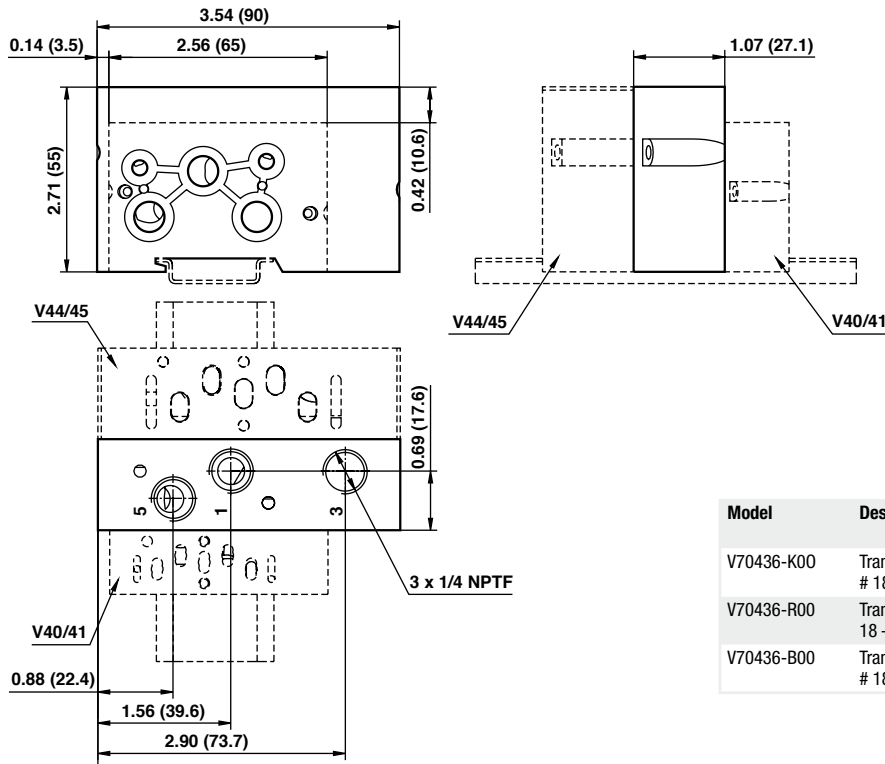

Model	Description	Port 1/3/5	Weight lb (kg)
V70436-K00	Transition Plate # 18 – # 26 mm	without Ports 1/3/5	0.71 (0.32)
V70436-R00	Transition Plate# 18 – # 26 mm	1/4 NPTF	0.68 (0.31)
V70436-B00	Transition Plate # 18 – # 26 mm	G1/4	0.68 (0.31)

Dimensions in inches (mm)