

# Spring-Set Electrically Released Brakes

## Spring Set Brakes

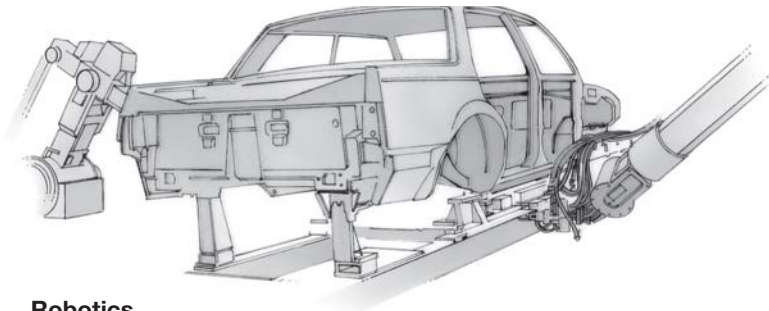

### Robotics

ERS Brakes can position and hold robotic equipment. Emergency braking in the event of power loss can prevent damage to equipment.

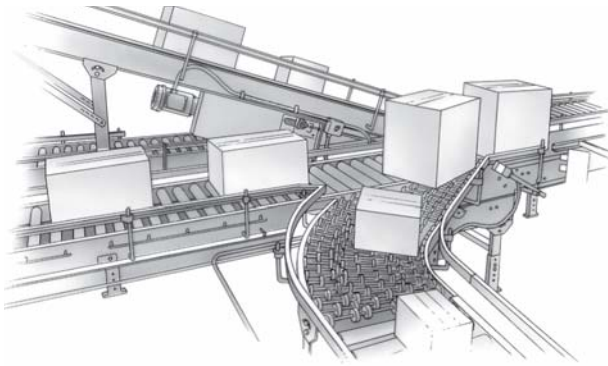

### Automated Material Handling Systems

ERS Brakes hold rollers and lift mechanisms in place, and lock drive wheels in place.

### Overhead Door

The ERD can be used in conjunction with a photo eye. In this application, whenever the light beam is broken, voltage to the brake is removed. The brake then applies and holds the door in position. Further, the manual release feature allows the operator to open/close the door in the event of a power failure.

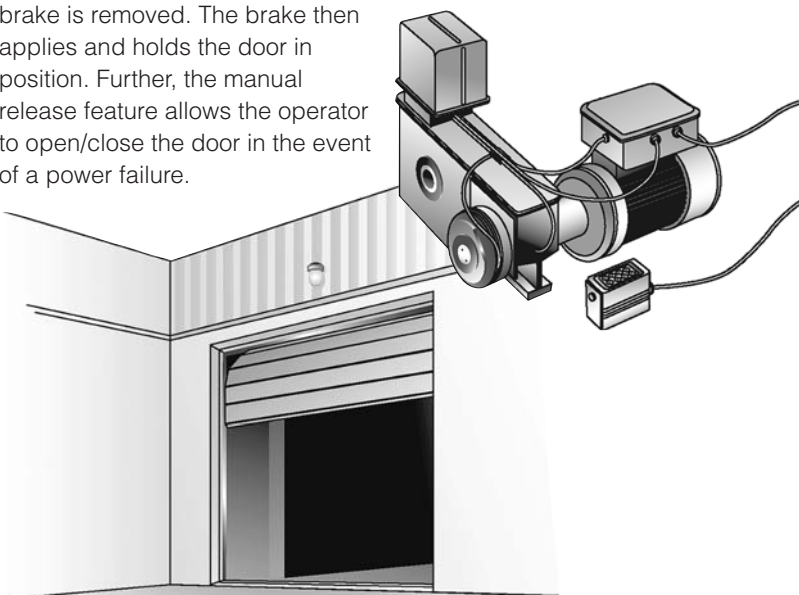

### Medical Equipment

ERS brakes are used as parking brakes in wheelchairs and holding brakes in medical apparatus such as mammography and cat scan equipment.



### Mobile Equipment

ERS Brake, applied as a parking brake function on lift trucks, prevent rolling on slanted surfaces without the need for manual brake linkage or expensive hydraulic brakes.

# ERS Series Electrically Released Brakes

## For Static Holding and Emergency Stopping

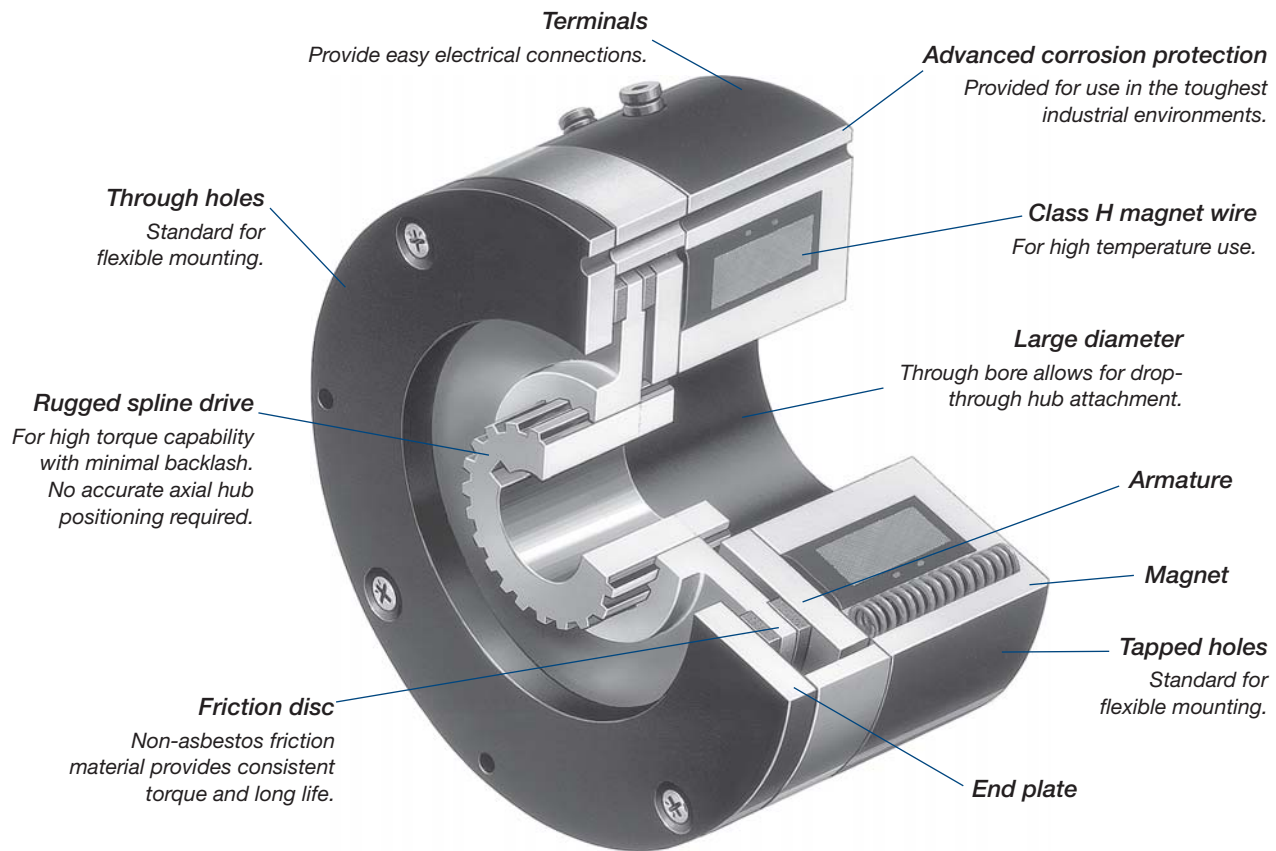

### Packaged Performance

Warner Electric ERS Brakes are pre-assembled and burnished at the factory. The engineering is built-in. Each unit is checked to ensure full rated torque right out-of-the-box. Just secure the hub, bolt down the brake and wire it up. An optional AC to DC control is available for use with all 90 volt units. Unique mounting features make it easy to adapt the ERS Brake to almost any application requirement.

ERS brakes are available in NEMA C-face mounted modules. Please consult factory for assistance.

### Features

- Designed for static holding operations
- Brake automatically engages when power is turned off
- Flexible mounting
- Electrically released – spring actuated
- Quick, quiet response for rapid engagement
- Compact, low profile design saves space
- Spline drive for high torque, minimal backlash and long life
- Available in five sizes. Static torque ratings from 1.5 lb.ft. to 100 lb.ft.
- ERS-26 and ERS-42 UL listed.

### Principle of Operation

ERS Brake torque is developed when springs apply a clamping force between the brake armature and the friction disc to the end plate. Spring clamping force provides the holding torque of the brake.

To release the brake, electrical power is applied to the magnet coil, generating a magnetic attractive force between the armature and magnet. The magnetic force overcomes the spring action, allowing the friction disc to rotate freely.

“Electrically Released” brakes are so named because, when power is removed, the brake will stop and hold a load. This occurs when power is lost either intentionally or unexpectedly due to a machine malfunction. When power is on, the brake electrically releases the load, allowing it to move freely.

# ERS Series Electrically Released Brakes

## Selection



### Sizing

Three factors are important for proper sizing:

- Static holding torque requirement
- System inertia and brake RPM
- Stopping time

### Step 1

#### Holding Torque

Select the size unit with torque capacity closest to, but not less than, the holding torque required.

Brake Size	Holding Torque Rating lb. ft.
ERS-26	1.5
ERS-42	7.0
ERS-49	15.0
ERS-57	34.0
ERS-68	100.0

### Step 2

#### System Inertia/Emergency Stop

In an emergency stop (when power is interrupted), the ERS Brake will engage and bring the load to a stop. To properly size a brake for this application, load inertia must be known. This is the total inertia of all components which are to be brought to a stop. Adding the inertia of the ERS Brake is not necessary; it has been included in the selection chart.

With the load inertia and brake RPM known, use the Emergency Stop Selection Chart to verify your brake selection. Simply locate the intersection of your RPM and inertia and make sure you are not above the line for the brake you selected based on Holding Torque (Step 1). If you are above the line, select the brake designated by the next higher line.

### Selection Procedure

ERS Brakes are available in five models for an optimum size to match your application requirements. Static torque capabilities range from 1.5 lb.ft. to 100 lb.ft.

The stopping function is an important consideration when deciding which brake to use. Will the brake be engaged and disengaged in a static condition (zero speed difference between the armature disc and the friction disc)? If yes, the ERS Brake is the right choice.

Will the brake be normally engaged and disengaged in a static condition with intermittent engagements dynamically? An emergency stop is a good example. If yes, the ERS Brake is the ideal choice.

Will the brake be subject to frequent dynamic braking action? If yes, then a Warner Electric ER, FB or ERD brake should be considered. The ERS Brake is not the best choice for use as a high cycle rate dynamic brake.

### Emergency Stop Selection Chart

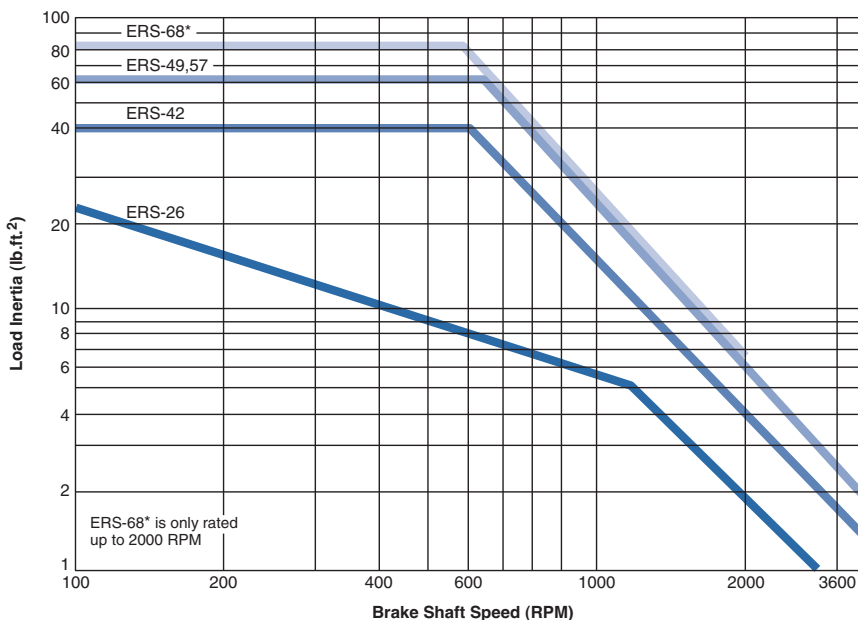

\*ERS-68 is only rated up to 2000 RPM

### Step 3

#### Stopping Time

In some applications, it is desirable to know how fast a brake will bring a load to rest. The time to stop a load can be determined if the system inertia and brake holding torque are known, according to the following equation:

$$\text{Where: } t = \frac{WR^2N}{308T}$$

t = time to stop the load in seconds (sec.)

WR<sup>2</sup> = system inertia at the brake location in pound-feet squared (lb.ft.<sup>2</sup>)

N = speed of the brake shaft in revolutions per minute (RPM)

T = rated brake holding torque in pound-feet (lb.ft.) See step 1, page 110.

Actual stopping times depend on application variables, which include brake temperature, electrical suppression (see the brake apply time data below), manufacturing tolerances, friction material wear, etc. For this reason, specific stop times should be evaluated under actual application conditions.

If your application has special requirements, please call us.

### Step 4

#### Select Control

Consult the Controls Section for control product overview. The holding torque for an ERS is not adjustable. Therefore, an adjustable torque control is not required.

### Brake Apply/Release Time (Typical Values)

Model	Brake Release Time (Seconds)		Brake Apply Time (Seconds)			
	24V	90V	Suppression Circuit A		Suppression Circuit B	
			24V	90V	24V	90V
ERS-26	0.03	0.03	0.04	0.04	0.01	0.01
ERS-42	0.05	0.06	0.10	0.10	0.01	0.02
ERS-49	0.07	0.08	0.15	0.15	0.02	0.02
ERS-57	0.11	0.11	0.15	0.15	0.02	0.02
ERS-68	0.16	0.20	0.20	0.20	0.03	0.03

Note: Release and Apply Times are armature engagement and release only.

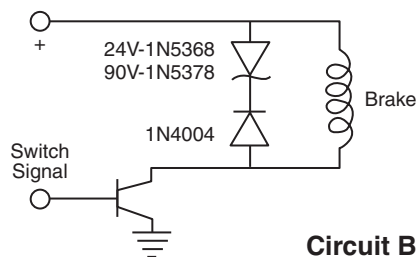
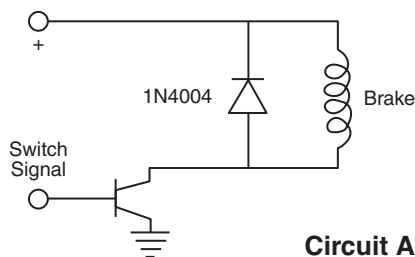

# ERS Series Electrically Released Brakes

## Armatures/Hubs

### Armature Drives

The rugged splined drive provides flexibility in selecting the most efficient method of coupling a load to the ERS Brake. Each unit size has standard splined hubs available for common shaft sizes.

#### Recessed Hub

For maximum space efficiency, mount hub on shaft, then mount brake over hub.

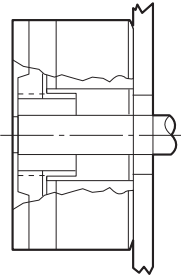

#### Extended Hub

Mount brake first, then position hub on shaft so hub is beyond the brake.

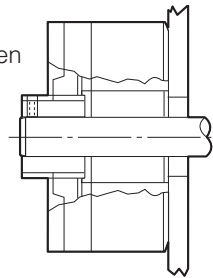

#### Mating Splined Member

Machined spline on drive member matches armature spline to operate brake.

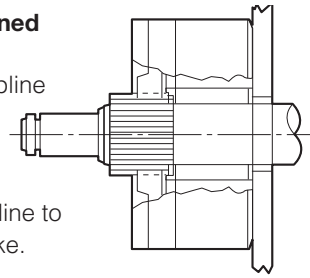

### Drive Hub/Spline and Interface Data

#### Set Screw Orientation

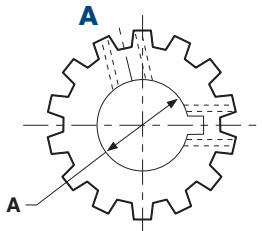

#### Set Screw Orientation

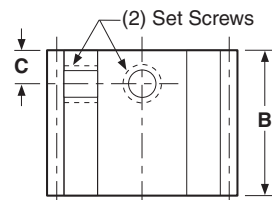
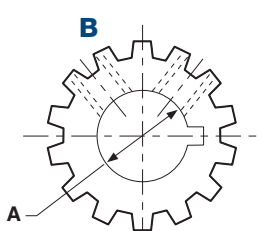

Model	A Bore	Mating Key (Not furnished)	Set screw Orientation	B Nom.	C Nom.	Set Screws	No. of Teeth	Dia. Pitch	Pressure Angle
ERS-26	.2525/.2505	1/16 x 1/16	B	.600	.135	6-32	14	20/40	30°
	.3150/.3130	1/16 x 1/16	B						
	.3775/.3755	3/32 x 3/32	B						
ERS-42	.3775/.3755	3/32 x 3/32	A	.700	.150	8-32	19	16/32	30°
	.5025/.5005	1/8 x 1/8	A						
	.6275/.6255	3/16 x 3/16	A						
	.7525/.7505	3/16 x 3/16	B						
	.3775/.3755	3/32 x 3/32	A						
ERS-49	.5025/.5005	1/8 x 1/8	A	.800	.160	10-32	21	16/32	30°
	.6275/.6255	3/16 x 3/16	A						
	.7525/.7505	3/16 x 3/16	B						
	.8775/.8755	3/16 x 3/16	B						
	.3775/.3755	3/32 x 3/32	A						
ERS-57	.5025/.5005	1/8 x 1/8	A	.800	.190	1/4-20	15	10/20	30°
	.6275/.6255	3/16 x 3/16	A						
	.7525/.7505	3/16 x 3/16	A						
	.8755/.8755	3/16 x 3/16	B						
	1.0025/1.0005	1/4 x 1/4	B						
ERS-68	1.0025/1.0005	1/4 x 1/4	A	.900	.190	1/4-20	22	10/20	30°
	1.1275/1.1255	1/4 x 1/4	A						
	1.2525/1.2505	1/4 x 1/4	A						
	1.3775/1.3755	5/16 x 5/16	A						
	1.5025/1.5005	3/8 x 3/8	B						

Note: Involute spline data per ANSI B92. 1a-1976, Class 5.

### Backlash

Total unit backlash includes spline and armature movement. It is typically less than one degree of rotation. Spline backlash alone is typically 15 minutes of rotation or less.

# ERS Series Electrically Released Brakes

## Mounting

### Mounting Orientation

ERS Brakes are easily modified to accommodate different mounting orientations. The brake can be mounted with either face against the mounting surface. The following mountings are possible with the standard ERS brake.

### Mounting Requirements

1. Mounting surface to be perpendicular to shaft with in .006" T.I.R.
2. Mounting holes to be within .015" true position to the shaft.

#### Through Bolt

Provides rigid support. May be mounted on either side of brake.

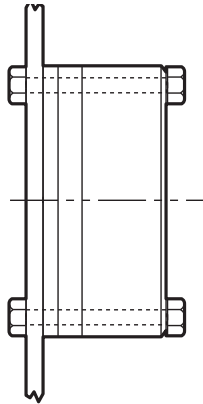

#### Tapped Hole

Works well where through bolt mounting is impractical.

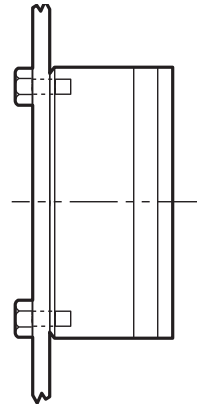

#### Flange

Flange mounting to brake tapped holes for most versatile attachment to many different housings, motors, and frames.

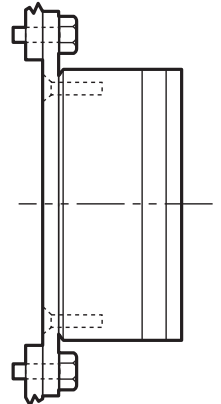

### Optional Adapter Mounting Flange

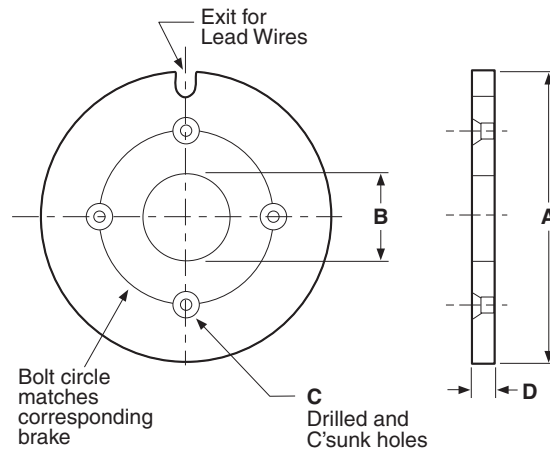

Model	A Nom.	B Nom.	C Holes	D Nom.
ERS-26	4.000	.935	#4	.100
ERS-42	5.000	1.450	#6	.144
ERS-49	6.250	1.575	#8	.193
ERS-57	7.500	1.825	#10	.193
ERS-68	9.500	2.500	1/4	.224

Note: Holes for attaching flange to mounting surface to be provided by customer.

# ERS Series Electrically Released Brakes

## Ordering Information

### Accessories

#### Adapter Flanges

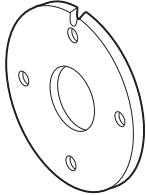

Model	Part Number
ERS-26	686-0182
ERS-42	686-0183
ERS-49	686-0184
ERS-57	686-0185
ERS-68	686-0186

#### Conduit Box

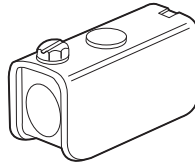

Model	Part Number
Conduit Box	5154-101-001
Mounts to ERS-49, 57 and 68 only	

#### Controls

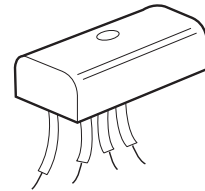

Model	Part Number
CBC-100-1	6003-448-101
AC to DC Control	
To be used with 90V ERS brakes	
See the Controls Section on page 201 for complete information.	
CBC-100-1 is 110 volt only	

### Ordering Information

Ordering the appropriate ERS brake for your application is a simple, step-by-step procedure based on the intended function, brake size, mounting configuration and operating voltage of the unit best suited for your needs, including any optional parts and accessories that you may require. A Warner Electric sales representative or distributor is always happy to provide assistance.

### How to Order

1. Verify that the brake is to be used in a static holding/intermittent engagement application.
2. Choose the correct size ERS Brake from the selection procedure on pages 110-111. Select the correct brake part number for the appropriate size and desired operating voltage.
3. Choose the splined hub part number for the required bore diameter and unit size.

4. Select optional accessories, such as: adapter flange kit, AC to DC control and conduit box kit.

### ERS Brake

Model	Voltage	Part Number
ERS-26	24V	5158-170-016
	90V	5158-170-015
ERS-42	24V	5151-170-002
	90V	5151-170-001
ERS-49	24V	5155-170-002
	90V	5155-170-001
ERS-57	24V	5153-170-003
	90V	5153-170-002
ERS-68	24V	5154-170-002
	90V	5154-170-001

### Splined Hub

Model	Bore Dia.	Part Number
ERS-26	.250	5158-541-006
	.312	5158-541-007
	.375	5158-541-008
ERS-42	.375	5151-541-002
	.500	5151-541-003
	.625	5151-541-004
ERS-49	.750	5151-541-005
	.375	5155-541-002
	.500	5155-541-003
ERS-57	.625	5155-541-004
	.750	5155-541-005
	.875	5155-541-006
ERS-68	1.000	5153-541-004
	.625	5153-541-005
	.750	5153-541-006
ERS-68	.875	5153-541-007
	1.000	5153-541-008
	1.000	5154-541-005
ERS-68	1.125	5154-541-006
	1.250	5154-541-007
	1.375	5154-541-008
ERS-68	1.500	5154-541-009

### Special Requirements

ERS Brake modifications such as metric bores, special voltages and low torque units are available. Consult factory.

# ERS Series Electrically Released Brakes

ERS-26, ERS-42, ERS-49, ERS-57, ERS-68

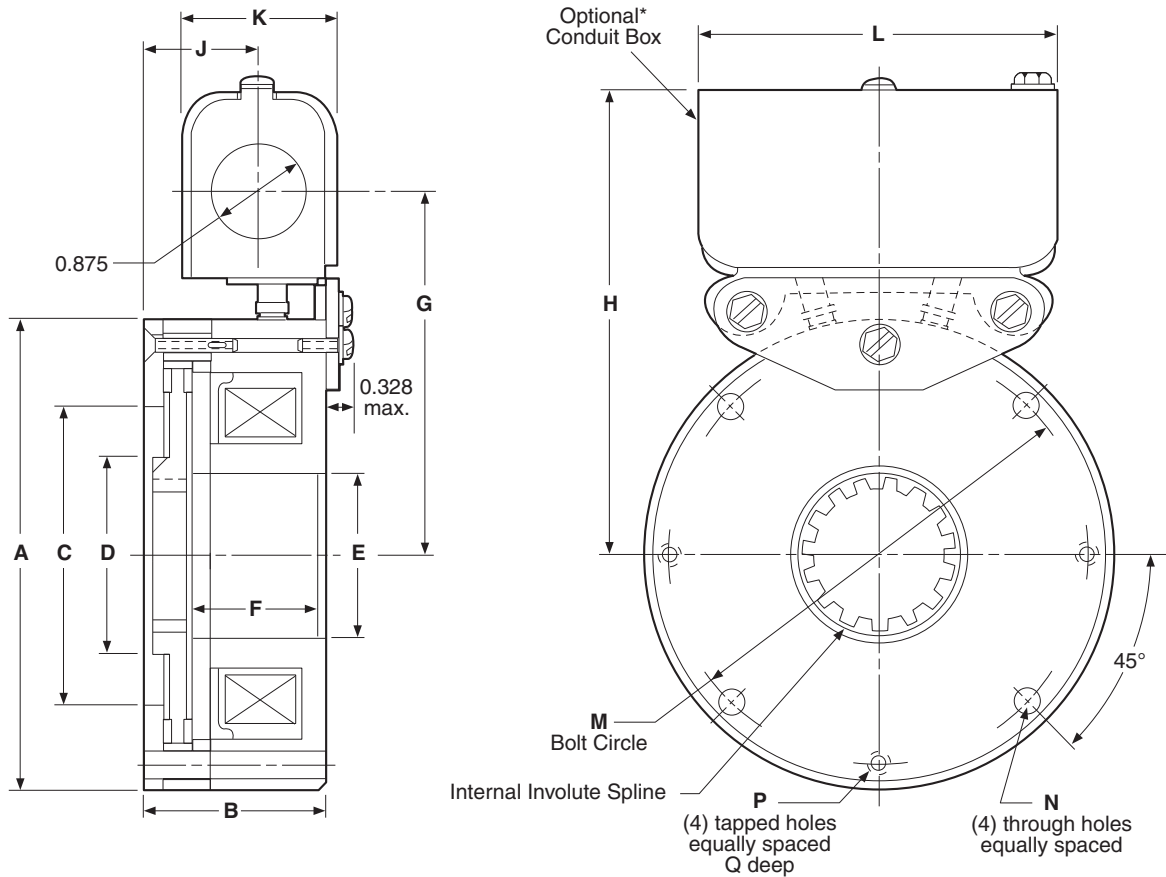

\*Available only for the ERS-49, 57, and 68 sizes



# ERS Series Electrically Released Brakes

## ERS-26, ERS-42, ERS-49, ERS-57, ERS-68

### Dimensions

All dimensions are nominal, unless otherwise noted.

Model	A Max.	B Max.	C	D	E	F	G
ERS-26	2.460	1.515	1.375	1.125	.860	1.250	—
ERS-42	3.520	1.595	2.000	1.600	1.375	1.255	—
ERS-49	4.270	1.767	2.600	1.750	1.500	1.332	3.625
ERS-57	5.020	1.937	3.240	2.100	1.750	1.503	4.000
ERS-68	6.520	2.030	4.504	2.800	2.425	1.565	4.750

Model	H	J	K	L	M Dia.	N Dia.	P	Q
ERS-26	—	—	—	—	2.125	.172/.164	4-40	.375
ERS-42	—	—	—	—	3.125	.200/.190	6-32	.400
ERS-49	4.625	1.000	1.625	3.750	3.750	.228/.218	8-32	.400
ERS-57	5.000	1.170	1.625	3.750	4.500	.288/.278	10-24	.400
ERS-68	5.750	1.265	1.625	3.750	5.875	.413/.404	1/4-20	.500

### Specifications

Model	Voltage DC	Power (Watts)	Current (Amperes)	Resistance (Ohms)	Static Torque (lb.ft.)	Inertia (lb.in. <sup>2</sup> )		Weight (lbs.)	
						Unit	Hub	Unit	Hub
ERS-26	24V	17.6	0.733	32.75	1.5	0.03	0.004	1.20	0.06
	90V	16.0	0.178	506.5					
ERS-42	24V	23.3	0.973	24.67	7	0.14	0.040	2.50	0.20
	90V	21.5	0.239	376.2					
ERS-49	24V	27.3	1.136	21.12	15	0.45	0.060	4.30	0.25
	90V	25.8	0.287	313.6					
ERS-57	24V	36.2	1.510	15.9	34	0.54	0.110	6.50	0.38
	90V	35.2	0.391	230.1					
ERS-68	24V	54.9	2.286	10.5	100	1.44	0.550	11.30	0.75
	90V	51.9	0.577	155.9					