

MAINA GEAR COUPLINGS

Maina is a high-quality manufacturer of gear coupling products that provide very long service life. Maina couplings are competitively priced for initial installation and because of their robust design are cost-effective in the long run. For these reasons they are specified by OEMs and users worldwide. The installed base of Maina couplings is growing very quickly also in the USA as customers become acquainted with their high performance and reliability.

Below are the ratings and maximum bore sizes for the range of standard Maina couplings now in stock at Johnson Power. Hubs are stocked rough bore and can be delivered rough bore or we will be happy to finish bore the hubs.

Size	Nominal Torque		Max. Torque		Max. Speed (rpm)	Max. Bore			
						Flex Hub		Rigid Hub	
	(kNm)	(10 ³ lb.-ft.)	(kNm)	(10 ³ lb.-ft.)		(mm)	(in.)	(mm)	(in.)
0	1.80	1.32	4.32	3.18	6000	52	2.05	60	2.36
1	2.76	2.03	6.62	4.88	4620	62	2.44	75	2.95
2	5.56	4.09	13.30	9.80	4140	78	3.07	90	3.54
3	8.70	6.41	20.90	15.40	4000	98	3.85	110	4.33
4	14.10	10.39	33.80	24.91	3860	112	4.40	130	5.11
5	22.80	16.80	54.70	40.31	3720	132	5.19	150	5.90
6	34.80	25.65	83.50	61.54	3190	156	6.14	175	6.89
7	44.00	32.43	105.60	77.83	2900	174	6.85	195	7.68
8	69.80	51.44	167.50	123.45	2570	190	7.48	220	8.66
9	83.80	61.76	201.20	148.28	2330	210	8.26	240	9.45
10	152.00	112.02	364.80	268.86	2150	233	9.17	260	10.45
11	203.50	149.98	488.40	359.95	1800	280	11.02	300	11.81

Standard Couplings

Standard couplings consist of two flex half couplings (GO-A) or the combination of a flex half coupling with a rigid hub (GO-FA). The GO-A flex-flex coupling permits angular, axial, and parallel offset. The GO-FA flex-rigid couplings will permit only angular and axial offsets. Up through size 3 all of the main coupling parts; flex hubs, sleeves, and rigid hubs are nitro-oxidized as a standard process. This treatment, which is identifiable from the black color it imparts, results in higher corrosion resistance and greater surface hardness for improved life.

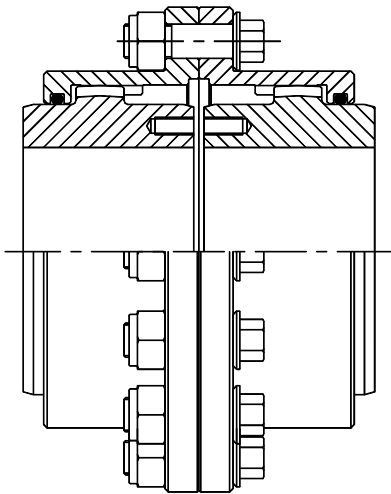

GO-A Coupling

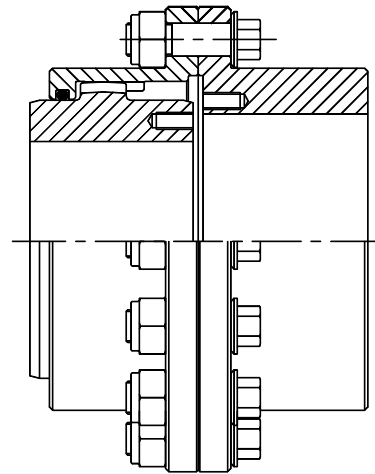

GO-FA Coupling

Extended Hub Couplings

Extended length hubs are used to increase the bore length to diameter ratio. This is useful to reduce keyway stresses and achieve the full coupling rating for hubs that are near the maximum bore size. The sleeves for these couplings are the same as for the standard couplings. Extended hub flex couplings may be used together (GO-AMM) or combined with rigid hubs (GO-FAM).

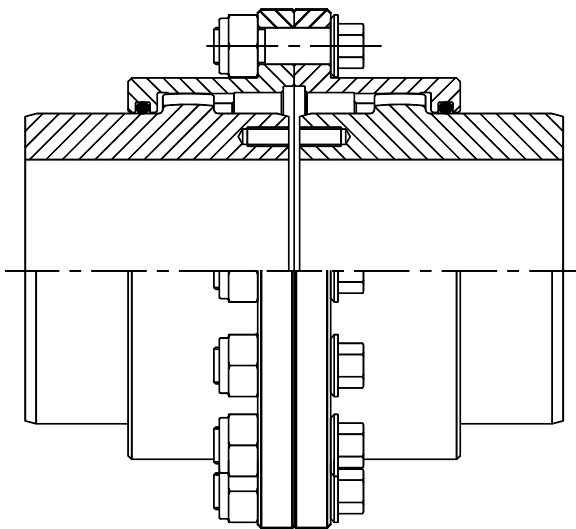

GO-AMM Coupling

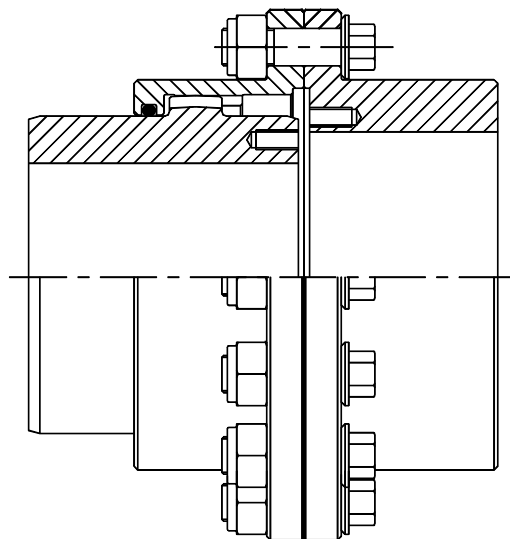

GO-FAM Coupling

Standard Couplings

It is possible to modify the distance between the shaft ends and overall coupling length by reversing one or both of the flex hubs. No modification to the standard parts is necessary when installing the parts in this fashion.

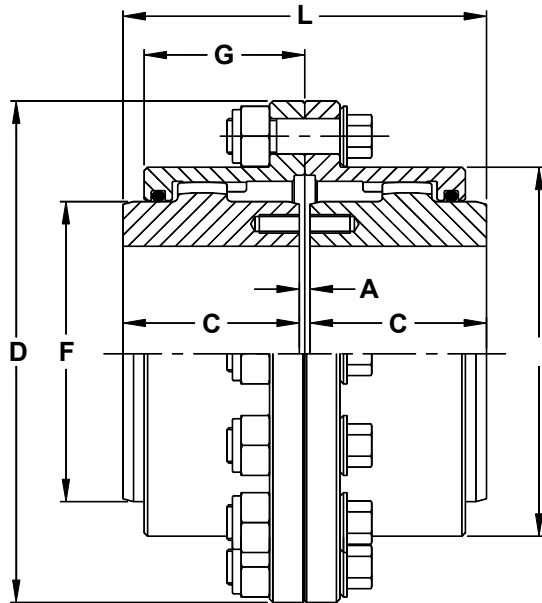

GO-A COUPLING

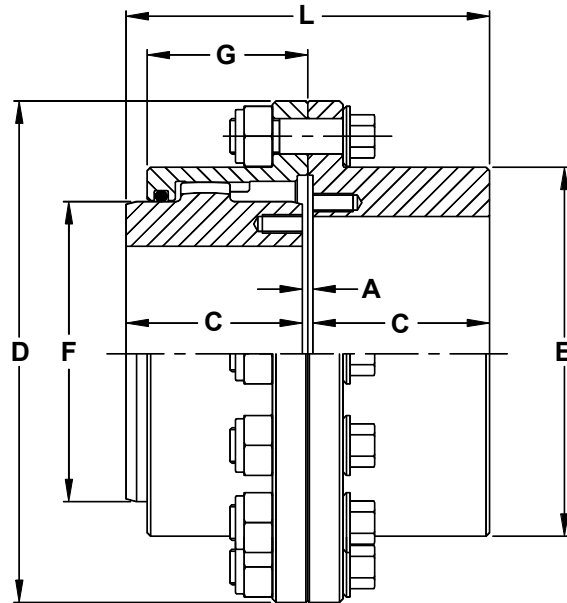

GO-FA COUPLING

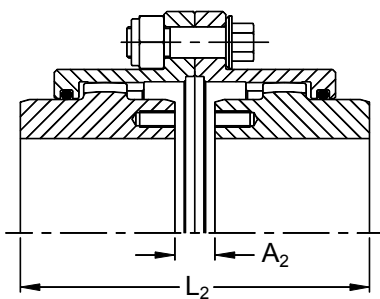

GO-ARR COUPLING

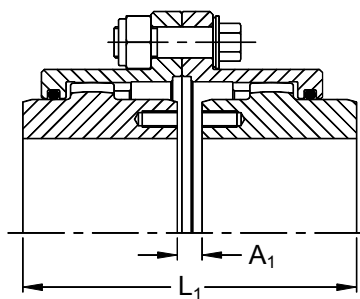

GO-AR COUPLING

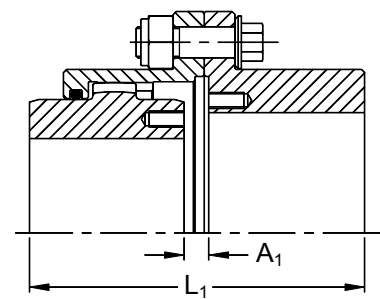

GO-FAR COUPLING

Coupling Dimensions in Millimeters

Size	D	E	F	G	C	A	A ₁	A ₂	L	L ₁	L ₂
0	111	82.5	69	39	43	3	5	7	89	91	93
1	142	104.5	85	45.5	50	3	8	13	103	108	113
2	168	130.5	107	59	62	3	14	25	127	138	149
3	200	158.5	133	68.5	76	5	12	19	157	164	171
4	225	183.5	152	82.5	90	5	24	43	185	204	223
5	265	211.5	178	93	105	6	27	48	216	237	258
6	300	245.5	209	106	120	6	32	58	246	272	298
7	330	275	234	118	135	8	37	66	278	307	336
8	370	307	254	138	150	8	50	92	308	350	392
9	406	335	279	154	175	8	53	98	358	403	448
10	439	367	305	166	190	8	58	108	388	438	488
11	505	423	355	193	220	10	72	134	450	512	574

Extended Hub Couplings

In addition to being used together or with rigid hubs, extended hub half couplings may also be used with standard flex half couplings. Extended hubs cannot be installed in the reversed position, but if an extended hub half coupling is combined with a standard flex half the hub can be either standard (GO-AM) or reversed (GO-AMR).

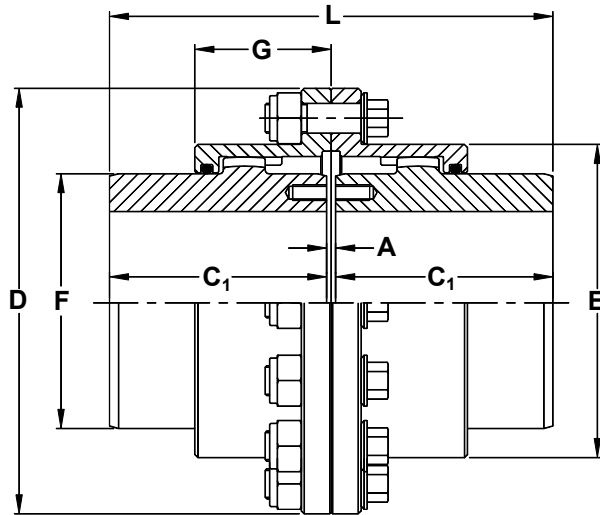

GO-AMM COUPLING

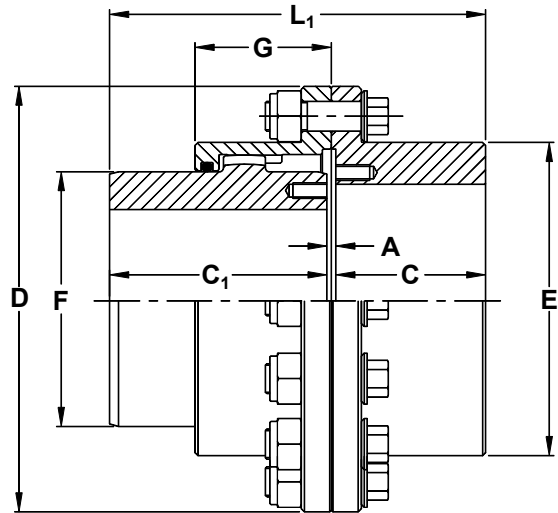

GO-FAM COUPLING

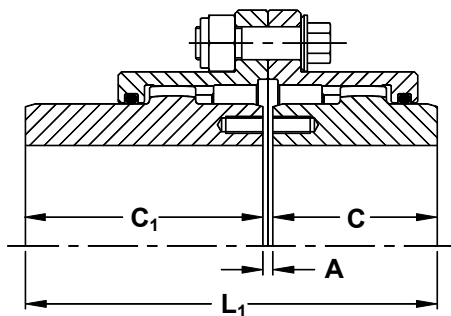

GO-AM COUPLING

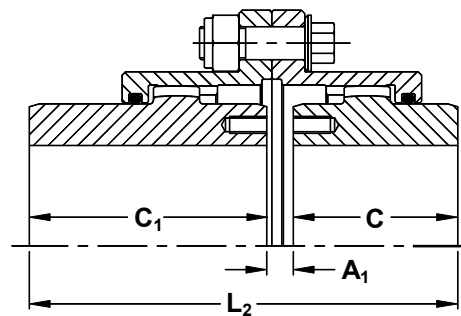

GO-AMR COUPLING

Coupling Dimensions in Millimeters											
Size	D	E	F	G	C	C ₁	A	A ₁	L	L ₁	L ₂
0	111	82.5	69	39	43	105	3	5	213	151	153
1	142	104.5	85	45.5	50	115	3	8	233	168	173
2	168	130.5	107	59	62	130	3	14	263	195	206
3	200	158.5	133	68.5	76	150	5	12	305	231	238
4	225	183.5	152	82.5	90	170	5	24	345	265	284
5	265	211.5	178	93	105	185	6	27	376	296	317
6	300	245.5	209	106	120	215	6	32	436	341	367
7	330	275	234	118	135	245	8	37	498	388	417
8	370	307	254	138	150	295	8	50	598	453	495
9	406	335	279	154	175	300	8	53	608	483	528
10	439	367	305	166	190	305	8	58	618	503	553
11	505	423	355	193	220	310	10	72	630	540	602

Mill Motor Couplings

Extended hubs can be modified and taper bored for use on AISE mill motor frames. The following table shows the available combination of coupling sizes and mill motor bores. Prices are available on request.

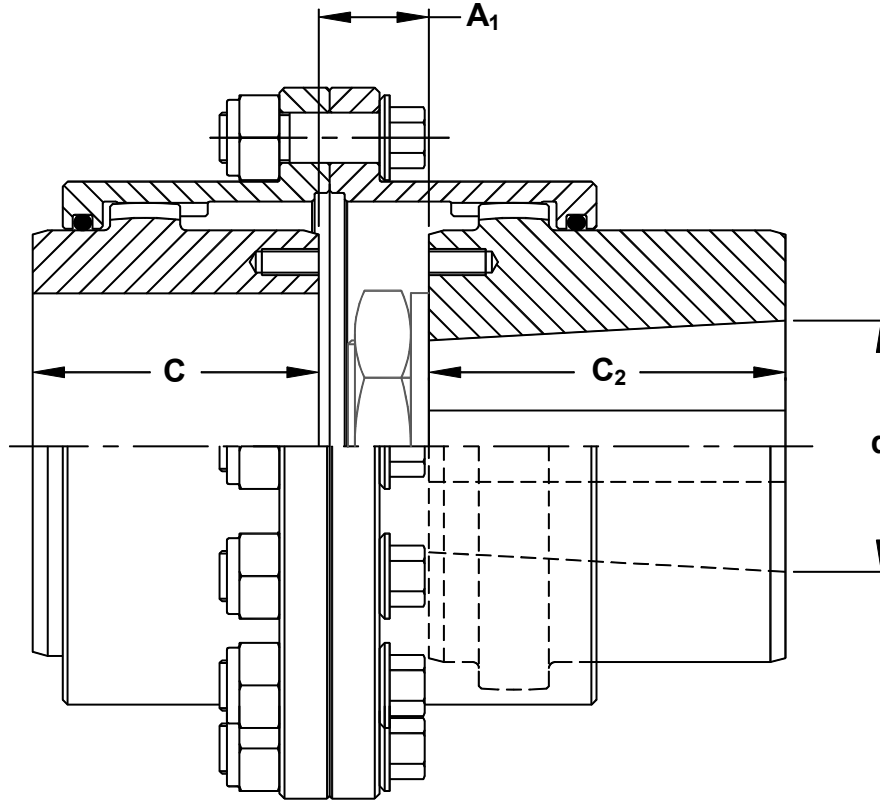

GO-AM.mm COUPLING

MILL MOTOR AISE 600-800 SERIES														
FRAME SIZE	Dimensions in Millimeters			A_1										
	d		C_2	Coupling Size										
	(in.)	(mm)		0A	1A	2A	3A	4A	5A	6A	7A	8A	9A	10A
602-802	1.750	44.450	75	28	28	28								
603-803	2.000	50.800	88		30	30	32							
604-804														
606-806	2.500	63.500	100			33	35	35						
608-808	3.000	76.200	113				38	38	39					
610-810	3.250	82.550	113					41	42	42				
612-812	3.750	92.075	125					45	46	46	48			
614-814	4.250	107.950	125						49	49	51	51		
616-816	4.625	117.457	138						52	52	54	54		
618-818	5.000	127.000	150							41	43	43	43	43
620-820	5.875	149.225	170								53	53	53	53
622-822	6.250	158.750	183									70	70	70
624-824	7.000	177.800	233										70	70



Spacer and Floating Shaft Couplings

For low angle applications with longer distances between shaft ends Johnson Power can modify standard coupling parts and fabricate spacer or floating shaft center sections. These longer length couplings come in two basic styles:

Spacer couplings:

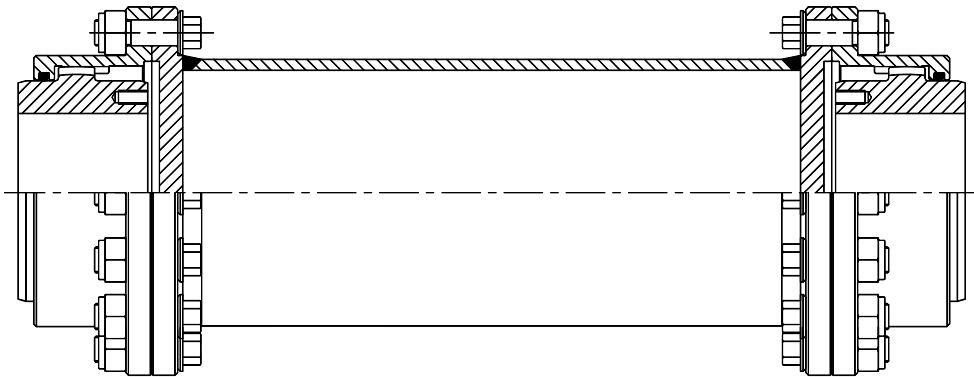

A tubular fabricated spool spacer is used as a center section between flex half couplings that are mounted on the shaft ends that are being joined together. The flex half couplings can use standard hubs, reversed hubs, extended hubs, or mill motor hubs.

Floating shaft couplings:

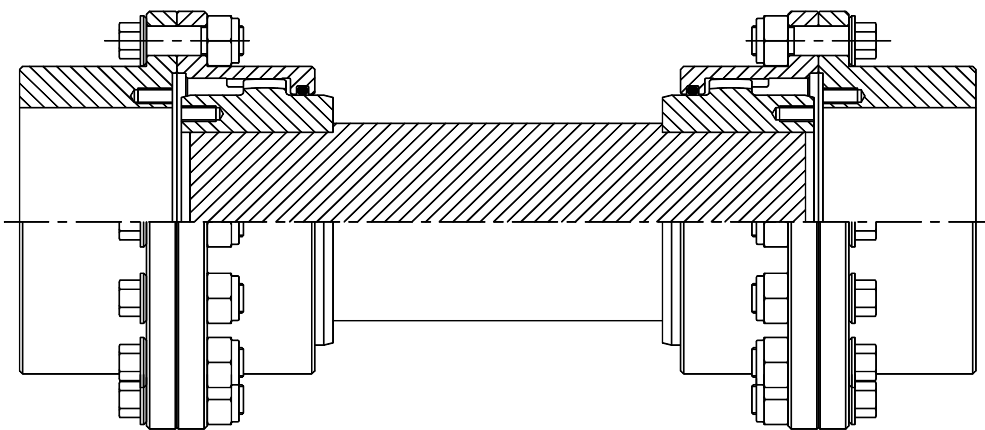

In this design rigid hubs are mounted on the shaft ends that are being joined together. The floating shaft center section consists of a machined shaft with flex halves on both ends. The flex half couplings can have standard hubs, reversed hubs, or extended hubs.

Prices for either of these designs are available upon request.

Non-Stock Couplings

Maina manufactures a variety of special coupling configurations and two series of high angle gear couplings. Some examples of these are featured below.

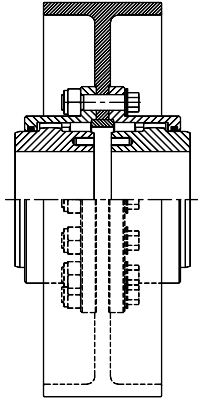

Coupling with integrated drum brake.

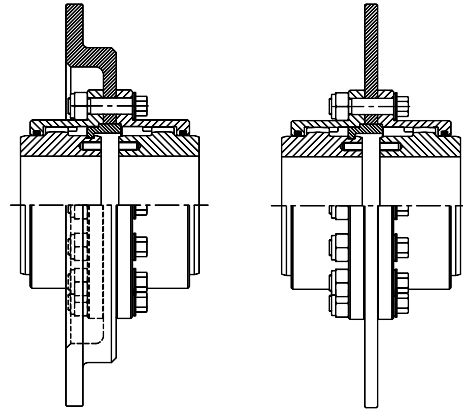

Coupling with integrated brake disc.

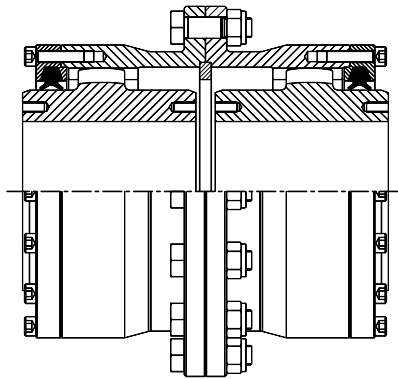

G20 series - high angle couplings
2° max. operating angle
12 different sizes
up to 843,800 lb.-ft. torque capacity

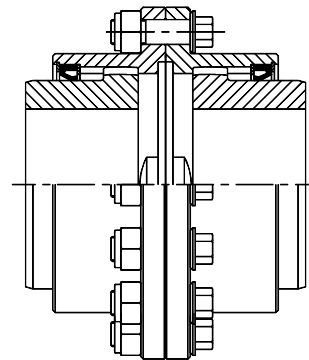

G35 series - high angle gear couplings
3°30' max. operating angle
11 different sizes
up to 202,675 lb.-ft. torque capacity

G60 series - high angle gear couplings
6° max. operating angle
11 different sizes
up to 114,235 lb.-ft. torque capacity

In addition to these, other designs are available. Please contact us with your inquiries for your custom gear coupling requirements. We will be happy to quote your special applications.

Installation and Maintenance (summary)

Below is a summary of the most important procedures and considerations suggested to maximize coupling life. Because of the widespread use of gear couplings, most of these recommendations are well known to gear coupling users. Further details are available upon request.

Proper alignment is the key to long life.

Standard gear couplings accommodate angular and axial offsets, but the lower the operating angle, the longer the life. The couplings should be installed with as small an angle as can be reasonably achieved. Laser alignment or other alignment tools should be used to facilitate meeting this objective.

Proper lubrication is essential to long life.

1. Couplings should be lubricated with a lithium soap based grease with EP additive. Examples include, but are not limited to, Esso Beacon EP and Mobil Temp 78. There are many alternatives from which to choose, since almost every grease manufacturer makes a grease for this and similar applications. It is very important that different kinds of greases not be mixed and even different brands of the same kind of grease should be checked for compatibility before use. Please consult us for special applications such as high speed, extreme temperatures, extreme humidity or water, etc. for special recommendations.

2. After shrink mounting the hubs on the shaft and positioning gear sleeves the cavity between the hub and sleeve should be filled with grease using a spatula. A thin mastic film should be applied to the mating flange faces and the coupling bolts should be tightened to the proper torque (refer to adjacent table).

GO-A SIZE	BOLT	TIGHTENING TORQUE (Nm)	NUMBER OF BOLTS
0	M8	18	6
1	M10	36	8
2	M10	36	10
3	M12	65	10
4	M12	65	12
5	M16	150	12
6	M16	150	14
7	M16	150	14
8	M18	220	14
9	M22	400	14
10	M22	400	14
11	M24	520	16

3. After connecting the flange halves fill the couplings through the grease nipples. When filling through the grease fittings make sure that the coupling is being filled. If there is difficulty in filling, remove a grease fitting or plug. Once you are sure that the coupling is filled, replace any of the grease fittings or plugs you have removed and properly tighten them.

4. After the first 3 months of operation the coupling should be relubricated. From then on the lubrication interval can be extended to 6 months but not exceed a maximum of 1 year. The lubrication interval should take into account the severity of operation.

5. When lubricating, totally replace the grease in the coupling. This is best done by removing the grease fitting 180° from the fitting that is being used to fill the coupling. Pump in fresh grease until it begins to purge from the opening. Once you are sure that the coupling is filled, replace any of the grease fittings or plugs you have removed and properly tighten them.

6. Every 8,000 working hours or 2 years, the coupling should be opened and the grease should be completely removed and replaced with fresh grease. The flange faces should be cleaned and reconnected following the instructions above in point 2.