

# The Ensat® – self-tapping threaded insert ...

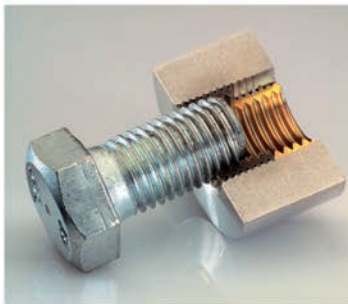

Ensats® is a self-tapping threaded insert with external and internal thread, cutting slots or cutting bores. A continuous process of further development has brought about a number of major improvements to product characteristics.

### Ensats®-S 302

(with cutting slot) is recommended for most application cases. In certain materials, this Ensats® demonstrates a minimal inward springing action, so creating a certain screw locking effect. (see page 7 to page 10)  
If this effect is not required, we recommend using Ensats®-SB 307/308.



### Ensats®-SB 307/308

(with cutting bores) was developed for materials with difficult cutting properties. This insert has a thick wall and the cutting force is distributed over three cutting edges. The short version Ensats® 307 is particularly suitable where minimal material thicknesses are involved. (see page 11 to page 15)

### Ensats®-SBS 337/338

with three chip reservoirs. Used primarily wherever only a small amount of chips may be permitted to occur during the tapping process (see page 16 to page 18).

### Thin-walled Ensats®-SBD 347/348

for applications involving special space conditions (residual wall thicknesses), and also suitable for driving using a thread tapping machine (same internal and external thread pitch, see page 19).

### Ensats®-SBT 357/358

with closed floor for additional sealing from below. (see page 21).



## Fields of application

The Ensats® is used throughout the whole of the metal and plastics processing industry.

- Automotive
- Plant and equipment construction
- Railway supply industry
- Electro-technics and laboratory techniques
- Household appliance
- Medical engineering
- Offshore

## Thread reparation

Ensats® is ideally suited for the fast repair of torn and damaged threads. The same screw size can be used again. (see page 30).

## Product features

- The Ensats® has a large effective shearing surface, so ensuring a higher degree of pull-out strength, i.e. an Ensats® M4 is often sufficient instead of a cut M5 thread (see page 5, Fig. 2).
- The Ensats® is driven subsequently into the finished workpiece. This means a higher casting machine output, no rejects due to incorrectly cast-in insert components, no moulding sand trapped in the thread.
- A pre-cast or pre-drilled retaining hole with normal tolerance requirements is sufficient for driving in the Ensats®. The thread is always precisely positioned.
- The Ensats® is insensitive to small areas of shrinkage. The Ensats®-system prevents damage caused by torn threads.



# The Ensats® – pull-out resistance due to flange cover ...

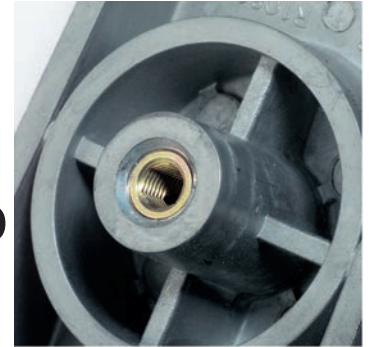

Connections using threaded insert Ensats® permit substantially smaller dimensions and consequently material and weight-saving designs.

The illustration below (Fig. 2) shows a screw connection with different screw cross-sections. Despite the smaller

screw cross-section, a screw joint with an Ensats® is capable of withstanding higher axial forces than the screw joint with larger screw cross-section; because the force - both under static and dynamic load - in the Ensats® male thread is distributed evenly over the individual thread turns of the Ensats® male thread.

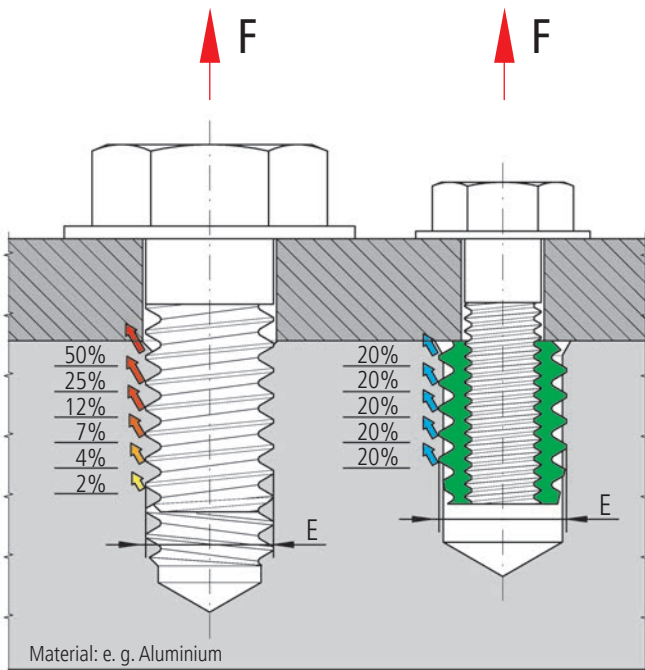

E = Diameter cut thread = Outside diameter of the Ensats®

Fig. 2

### Flange cover

In a workpiece made of a light alloy, the Ensats® 302 achieves almost maximum pull-out strength with only 30 % flange cover (Fig. 3).

### Pull-out strength

The Ensats® is capable of withstanding high loads. When used in light alloys, for example, a degree of pull-out strength is achieved which far exceeds the yield strength of the mating screw 8.8 (Fig. 4).

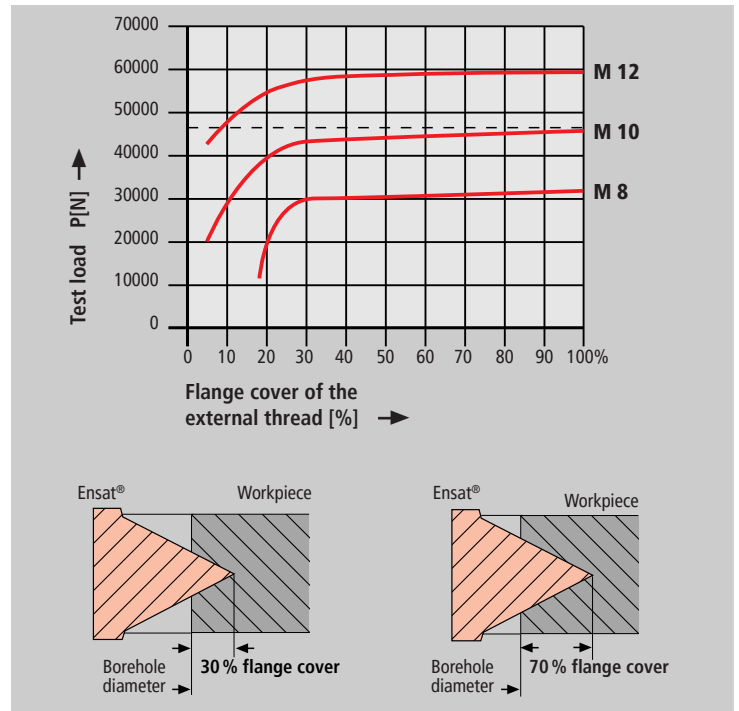

Fig. 3

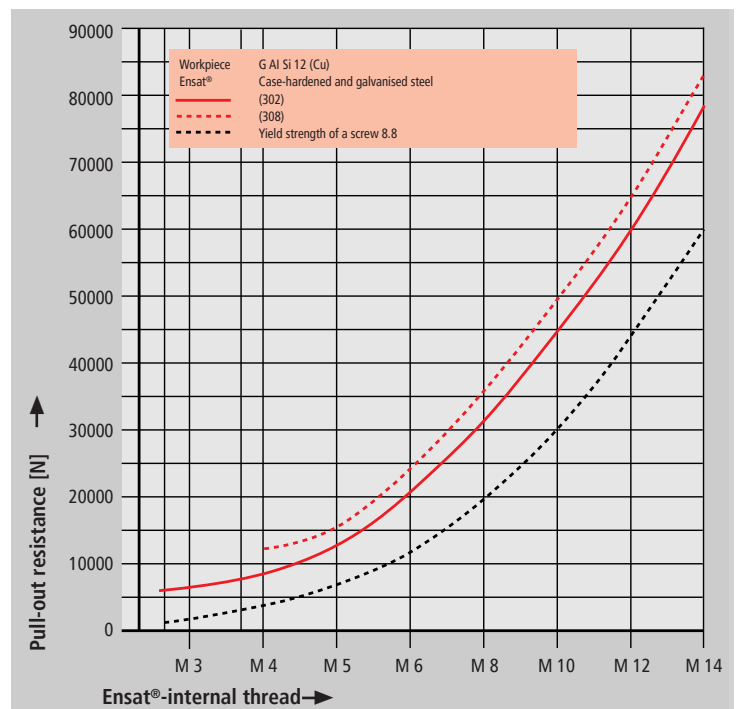

Fig. 4

# The Ensat® in the workpiece ...

## Installation recommendation

The Ensat® should be recessed appr. 0,1 – 0,2 mm recessed (Fig. 5). After processing, the Ensat® can be immediately subjected to load. If the component material permits subsidence of the Ensat® under load, the Ensat® can only execute an axial movement of 0,1 to 0,2 mm. In other words, the pretension of the screw union is largely retained, loosening of the screw connection under dynamic load is impeded

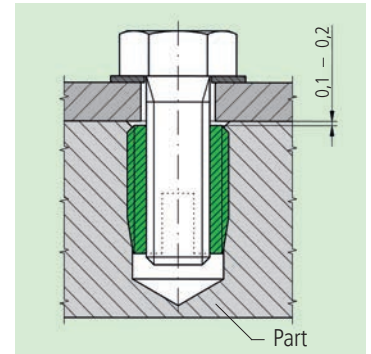



Fig. 5

The adjacent table is used to determine the recommended bore hole diameter depending on the material of the workpiece and the Ensat® type/dimension.

### Example:

Light alloy workpiece  
Internal thread M8,  
recommended bore hole diameter for  
**Ensats®-S 302:** 11,2 to 11,4 mm  
**Ensats®-SB 307/308:** 11,2 to 11,5 mm

In case of processing problems (e.g. markedly increased screw-in torque levels) there is generally no harm in selecting diameter data in the next highest column. In case of doubt, we advise carrying out a test.

Light alloys Ms, Bronze, NF-Metal, Cast iron								
Borehole diameter [mm]		Guideline values for Ensats® 302			Guideline values for Ensats® 307/308			
					337 / 338 357 / 358			
<b>Ensats® internal thread</b>	M 2 / M 2,5	Inch	4,1	4,2	4,3	–	–	–
	M 3	N° 4	4,6	4,7	4,8	4,7	4,8	–
	M 3,5	N° 6	5,5	5,6	5,7	5,6	5,7	–
	M 4	N° 8	6,0	6,1	6,2	6,1	6,2	–
	M 5	N° 10	7,3	7,5	7,6	7,5	7,6	7,7
	M 6(a)	–	8,3	8,5	8,6	–	–	–
	M 6	1/4"	9,0	9,2	9,4	9,4	9,5	9,6
	M 8	5/16"	11,0	11,2	11,4	11,2	11,3	11,5
	M 10	3/8"	13,0	13,2	13,4	13,2	13,3	13,5
	M 12	7/16"	15,0	15,2	15,4	15,1	15,2	15,4
	M 14	1/2"	17,0	17,2	17,4	17,1	17,2	17,4
	M 16	5/8"	19,0	19,2	19,4	19,1	19,2	19,4
	M 18	–	21,0	21,2	21,4	21,1	21,2	21,4
	M 20 / M22	3/4"	25,0	25,2	25,4	25,1	25,2	25,4
M 24	–	29,0	29,2	29,4	29,1	29,2	29,4	
M 27	–	33,0	33,2	33,4	–	–	–	
M 30	–	35,0	35,2	35,4	–	–	–	
<b>Flange cover appr.</b>			50 %	40 %	30 %	70 %	60 %	50 %

**Recommended borehole diameter for easy assembly.**

Fig. 6

## Retaining hole

The retaining hole (L) can be simply drilled or integrated into in the casting.

Countersinking (N) the borehole (Fig. 7) is recommended in order to:

- Prevent the workpiece surface from being raised
- Permit screwing in to a greater depth
- Ensure improved initial cutting characteristics

### Material thickness:

Length of the Ensats® = smallest admissible material thickness M.

### Depth of the blind hole:

Minimum depth – (T) see Works Standard page 7 to 21

### Borehole diameter:

Brittle, tough and hard materials call for a larger borehole than soft or elastic materials. For guideline values, see the table above (Fig. 6).

### Edge distance:

The smallest still admissible edge distance W (Fig. 7) depends on the planned stress level and the elasticity of the material into which the Ensats® is screwed.

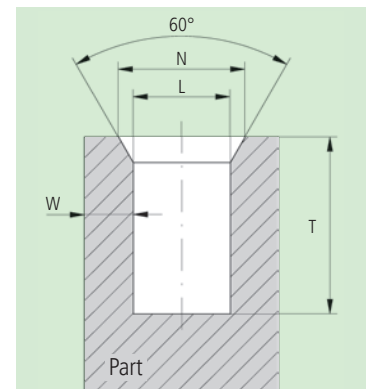

**Guideline values for countersink:**  
N = 0,06 to 0,08 x E + E

**Guideline values for light alloys:**  
W 0,2 to 0,6 x E

**Guideline values for cast iron:**  
W 0,3 to 0,5 x E

E = Outside diameter of the Ensats® [mm]

Fig. 7

# Ensat® – driving tools...

On this page, you can configure the optimum tool for your application. A configuration is provided in the following as an illustrative example.

The article number is composed of two sequences of numbers and starts with the tool shank (Fig. 9) which should be selected in accordance with your output.

Also encrypted in this number are the special versions for thin-walled Ensat® (620 1 and 621 1) and for very high driving torques (622 0 and 623 0) which are available as standard only as a square shank. Other non-standard geometries can be evaluated as standard besides the tools illustrated. The second sequence of numbers in the table (Fig. 10) indicates the thread code of the female thread. The tightened dimensions of the tools are shown on the next page.

**Tool for accessible retaining boreholes (short)**

- 1 Shank
- 4 Stop pin
- 9 Ball
- 5 Fixing screw
- 6 Ball bearing
- 2 Shell
- 3 Guide bush
- 7 Stud

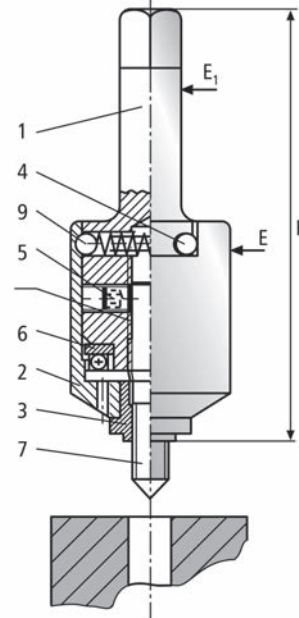

**Tool for deep located retaining boreholes (long)**

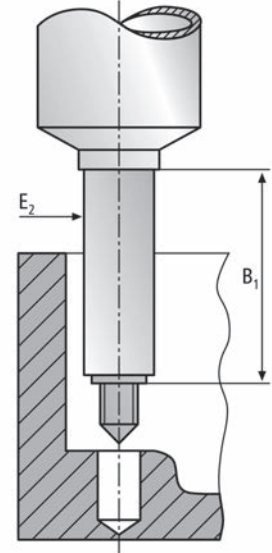

Fig. 8

**Example:**

You wish to insert an Ensat® 308 000 050. 110. For the installation process, you have selected a driving tool with spindle hexagon socket to DIN ISO 1173 and have to mount the insert into a deep positioned borehole.

- Shank: **636 0...** (long for deep positioned borehole)
- Thread code: **...00 050...** (for thread M5)
- Suffix numbers: **.... 000** (with always the same tools)

Order no: **636 000 050.000**

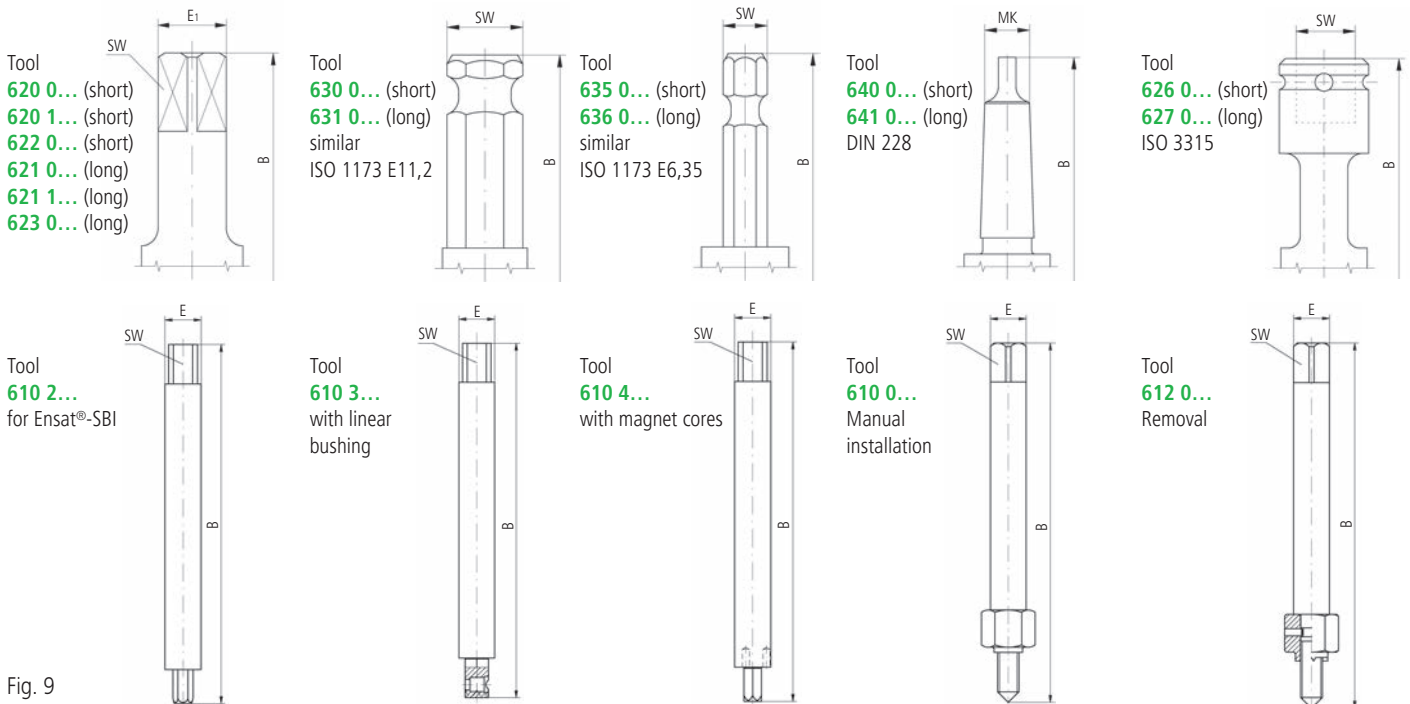

Fig. 9

Art. no.	For Ensaf®	M 2	M 2,5	M 3	M 3,5	M 4	M 5	M 6	M 8	M 10	M 12	M 14	M 16	M 18	M 20	M 22	M 24	M 27	M 30
Metric	...0 020.000	...0 025.000	...0 030.000	...0 035.000	...0 040.000	...0 040.000	...0 050.000	...0 060.000	...0 080.000	...0 100.000	...0 120.000	...0 140.000	...0 160.000	...0 180.000	...0 200.000	...0 220.000	...0 240.000	...0 270.000	...0 300.000
Whit worth	—	—	—	—	—	—	—	...0 525.000	...0 531.000	...0 537.000	...0 544.000	...0 550.000	...0 562.000	—	—	—	—	—	—
UNC	—	—	...0 604.000	...0 606.000	...0 608.000	...0 608.000	...0 610.000	...0 625.000	...0 631.000	...0 637.000	...0 644.000	...0 650.000	...0 662.000	—	—	—	—	—	—
UNF	—	—	...0 704.000	...0 706.000	...0 708.000	...0 710.000	...0 731.000	...0 725.000	...0 731.000	...0 737.000	...0 744.000	...0 750.000	...0 762.000	—	—	—	—	—	—
<b>Measurement table</b>																			
<b>Tool type 620 0... (short version), 620 1... (Variant for thin-walled ENSAF®) und 621 0... (long version), 621 1... (Variant for thin-walled ENSAF®)</b>																			
E <sub>1</sub>	8	8	8	8	8	8	12,5	12,5	12,5	16	16	25	25	25	25	25	30	30	30
SW	6,3	6,3	6,3	6,3	6,3	6,3	10	10	10	12,5	12,5	20	20	20	20	20	25	25	25
B	78	78	78	78	78	78	95	95	95	118	118	145	145	145	169	169	198	198	198
B <sub>1</sub>	40	40	40	40	40	40	50	50	50	60	60	60	60	60	60	60	60	60	60
E	18	18	18	18	18	18	24	24	24	32	32	50	50	50	58	58	70	70	70
E <sub>2</sub>	7	7	7	7	7	7	9	10	12	15	18	20	22	24	26	28	32	35	38
<b>Tool type 622 0... (short version, reinforced version for high installation torques) and 623 0... (long version, reinforced version for high installation torques)</b>																			
E	○	○	○	○	○	○	36	36	36	43	43	○	○	○	○	○	○	○	○
<b>Tool type 630 0... (short version, hexagonal shaft) and 631 0... (long version, hexagonal shaft)</b>																			
SW	11,11	11,11	11,11	11,11	11,11	11,11	11,11	11,11	11,11	11,11	11,11	11,11	11,11	11,11	—	—	—	—	—
B	71	71	71	71	71	71	83	83	83	98	98	118	118	118	—	—	—	—	—
<b>Tool type 635 0... (short version, hexagonal shaft) and 636 0... (long version, hexagonal shaft)</b>																			
SW	6,35	6,35	6,35	6,35	6,35	6,35	6,35	6,35	6,35	6,35	6,35	—	—	—	—	—	—	—	—
B	66	66	66	66	66	66	78	78	78	93	93	—	—	—	—	—	—	—	—
<b>Tool type 640 0... (short version, morse taper shaft) and 641 0... (long version, morse taper shaft)</b>																			
MK	MK0	MK0	MK0	MK0	MK0	MK0	MK2	MK2	MK2	MK3	MK3	MK4	MK4	MK4	MK4	MK4	MK4	MK4	MK4
B	○	○	○	○	○	○	○	○	○	○	○	○	222,5	○	○	○	○	○	○
<b>Tool type 626 0... (short version, square socket shank) and 627 0... (long version, square socket shank)</b>																			
SW	—	—	—	—	—	—	1/2"	1/2"	1/2"	1/2"	1/2"	1/2"	1/2"	1/2"	1/2"	1/2"	1/2"	1/2"	1/2"
B	—	—	—	—	—	—	94,5	94,5	94,5	117,5	117,5	140,5	140,5	140,5	168,5	168,5	197,5	197,5	197,5
<b>Tool type 610 2..., 610 3... (from M 8), 610 4... (from M 6) – (for ENSAF® with hexagon socket)</b>																			
E	—	—	—	—	—	—	8	10	10	12	14	16	18	—	—	—	—	—	—
B	—	—	—	—	—	—	90	100	100	110	125	125	125	—	—	—	—	—	—
SW	—	—	—	—	—	—	6,2	8	8	9	11	12	15	—	—	—	—	—	—
<b>Tool type 610 0..., 612 0... (manual driving tools)</b>																			
E	—	6	6	6	6	6	10	10	10	16	16	16	—	—	—	—	—	—	—
B	—	55	55	60	60	60	75	75	75	95	95	95	—	—	—	—	—	—	—
SW	—	5	5	5	5	5	8	8	8	12,5	12,5	12,5	—	—	—	—	—	—	—

In order to obtain the length dimension of the extended tool versions, the specified dimensions B must be added in each case to the dimension B<sub>1</sub>.

○ = available on request

Fig. 10

# Manual Ensat® - installation ...

Manual installation with driving tool and tap wrench:

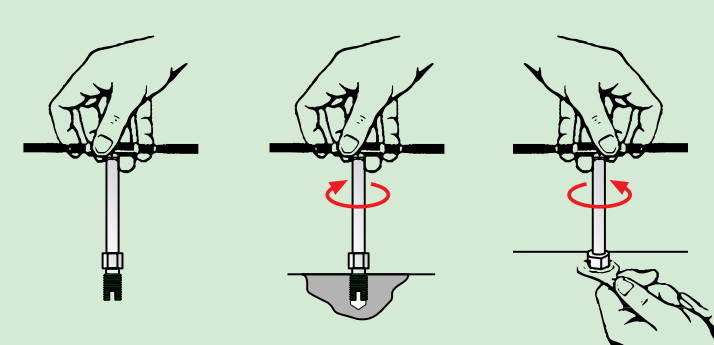

Fig. 11

Emergency installation using screw and nut:

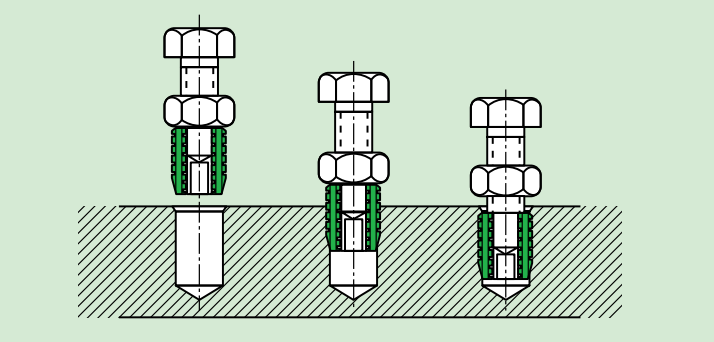

Fig. 12

The right length of the threaded pin for the Ensat® with cutting slot or with cutting bore is calculated from the pitch of the female thread (see also Fig. below;  $P$  = pitch of the female thread).

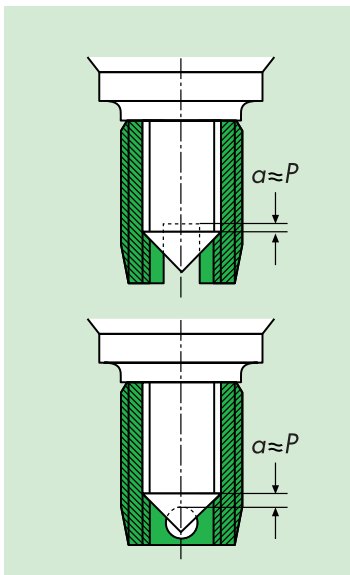

Fig. 13

## Setting or exchanging the stud

- Pull the shell (2) downwards off the shank (1).
- Release the locking screws (5).
- Screw the stud (7) in or out. Yellow colour marking indicates flattened surfaces for the locking screws.
- When assembling, tighten both screws (5) evenly.
- Insert the ball bearing (6).
- Push on the shell (2) until the ball stop locks into place. For the tool to function perfectly, the shell must be very easy to rotate. Shorten the thread of tool 610 accordingly for short Ensat®.

## Manual installation

Manual installation usually takes place using the manual driving tools 610 0... at the female thread or when using tools 610 2... at the hexagonal socket. The machine tools can naturally also be used for manual installation. However, here it is important to ensure that the rotatable shell (2) is positioned correctly (see Fig. 17 process description).

1. Drill the hole: Diameter, countersink if necessary (see page 6)
2. Screw the Ensat® onto the driving tool, with the cutting slot or cutting bore pointing downwards.
3. Take care not to tilt sideways. In machine tools, the rotatable shell (2) must rest against the externally visible stop pins so that it is driven by the pins in the clockwise direction. Screw in the Ensat® until around 0.1 – 0.2mm under the workpiece surface.
4. Back out the driver tool. This causes the machine tool to become automatically released from the Ensat®. With tool 610 0..., the shoulder must be held by means of a spanner until the lock breaks.

## Conditions for flawless tool function

- Unscrew the guide bush (3) at the front if the Ensat® is to be installed deeper than 0.2 mm under the surface of the workpiece. Diameter: 0.1 to 0.2 mm smaller than Ensat® retaining hole.
  - Locking and unlocking the tool on the Ensat® surface is guaranteed by a thrust bearing (6).
  - The stop pins (4) execute the impact at the shell (2) which unlocks the tool.
  - Wear at the stud (7) can result in unlocking problems.
- For mounting thin-walled Ensat® (page 19), special guide bushes must be used (tools 620 1 and 621 1).

The components are also offered as single parts to allow you to carry out your own repairs to the tool. Simply give us a call.



Fig. 14

# Machine Ensats® - installation...

## Machine driving process

1. Precisely position the workpiece so that the bore and machine spindle are at right angles to each other (do not tilt).  
Set the machine to the precise installation depth (appr. 0.1 to 0.2 mm below the surface of the workpiece see page 6).
2. Actuate the operating lever of the machine.  
The rotatable outer shell of the tool must be resting against the outer visible stop pins at the beginning of the turning process so that it is driven by the pins in the clockwise direction.
3. Feed the Ensats® towards the tool (slot or cutting hole facing downwards) and grip for the duration of 2 to 4 revolutions.
4. Continue to actuate the operating lever of the machine and to guide the tool to the hole until the Ensats® cuts into the borehole. The remainder of the driving process takes place without actuating the feed.
5. Switch on the reversing function (depending on the type and structure of the device, this takes place automatically by means of a limit switch / depth sensor). Avoid setting the tool down hard on the workpiece as this can lead to breakage of both the tool and the Ensats®. It can also damage the play-free fit of the Ensats® and so reduce the pull-out strength. If necessary, adapt the driving speed in line with the necessary reversal time.

Machine installation takes place using the driving tools illustrated on page 27, mounted in:

### 1. Thread tapping machine

### 2. Drill press

with reversing system by means of depth stop or thread cutting head. Without guide cartridge, without feed.  
Important: Do not exceed tightening torques.

### 3. Manual machine

With depth sensor and reversing system. See Fig. 13.

### 4. Single or multiple installation machines

With pneumatic or electric drive; semi or fully automatic, computer controlled (CNC).  
Note different pitches.

## Guideline speed values for light alloy:

Ensats® female thread	Speed rpm [min <sup>-1</sup> ]
M 2,5 / M 3	650 – 900
M 4 / M 5	400 – 600
M 6 / M 8	280 – 400
M 10 / M 12	200 – 300
M 14 / M 16	150 – 200
M 18 / M 20	120 – 200
M 22 / M 24	100 – 160
M 27 / M 30	80 – 140

Fig. 15

## Guideline values for driving torques

Ensats® M 2,5	1,5 Nm
Ensats® M 3	2,5 Nm
Ensats® M 4	5,5 Nm
Ensats® M 5	10 Nm
Ensats® M 6	15 Nm
Ensats® M 8	28 Nm
Ensats® M 10	40 Nm
Ensats® M 12	60 Nm
Ensats® M 14	100 Nm
Ensats® M 16	160 Nm
Ensats® M 18	220 Nm
Ensats® M 20	310 Nm
Ensats® M 22	420 Nm
Ensats® M 24	530 Nm
Ensats® M 27	770 Nm
Ensats® M 30	1050 Nm

Fig. 16

## Torque M<sub>D</sub>

The maximum admissible torque is dependent on:

1. The axial load capacity of the tool stud
2. The pressure resistance capacity of the Ensats® in the axial direction

## Lubrication

Only in the case of materials with difficult cutting properties.

**For medium-hard light alloys:**  
Cutting oil, spirit or petroleum.

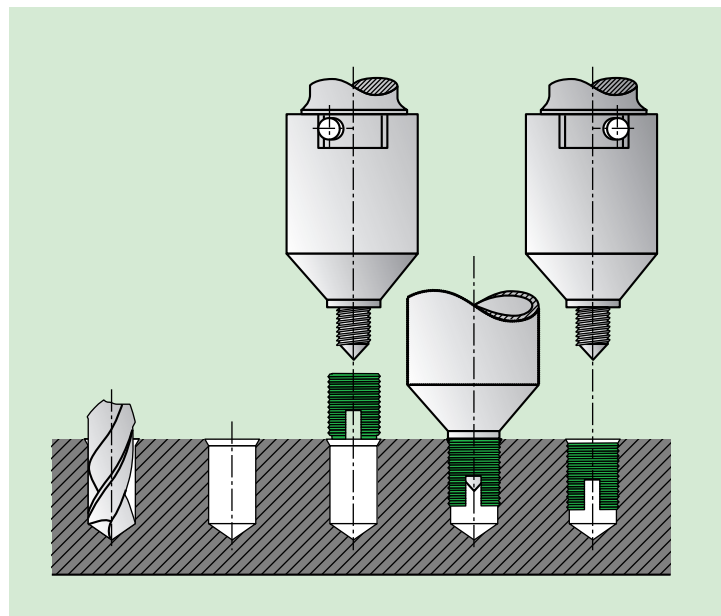

Fig. 17