



BRAND
HYDRAULICS Co.

Made in the Heartland of America
Serving the World

Engineering & Manufacturing Solutions

AO

4-Way Directional
Control Valve

Specifications:

- Rated for 0-18 gpm (0-68.1 lpm)
- Rated for 3000 psi (207 bar)
- Weighs 5-1/2 lbs. (2.5 kg)
- 30 – Micron filtration recommended



ISO 9001:2008 WITH DESIGN
Certificate #02.002.1

AO12004GS

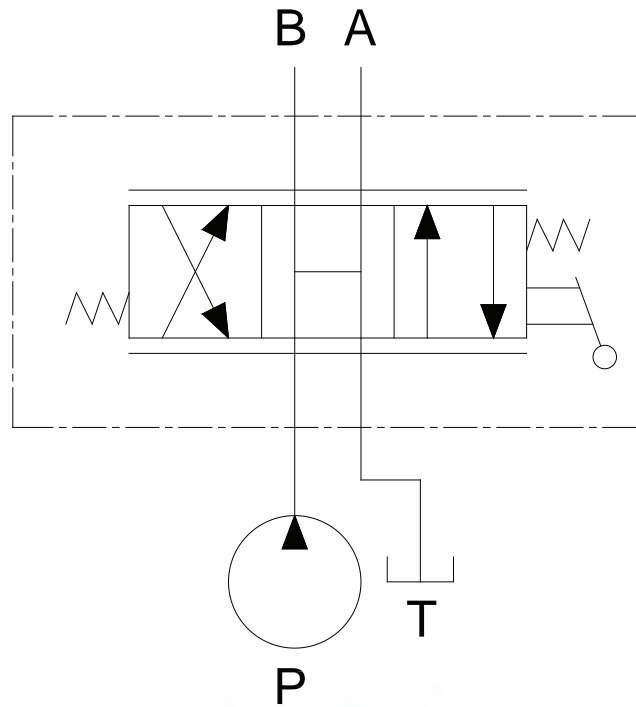
**MATERIALS:**

- Cast Iron Body
- Buna N O'Rings
- IOSSO Plated Steel Spool
- Consult Factory for Stainless Steel Spools
- Black Nylon Ball Knob

FEATURES:

- SMALL AND COMPACT to fit your design requirements.
- POSITIVE METERING in either direction with the manually shifting handle.
- PRECISION GROUND IOSSO PLATED SPOOL that assures long life.
- OPTIONAL O-RING PORTS to eliminate leakage.

AO – GENERAL INFORMATION:

The Brand, 4-way directional control valve is designed to be durable and dependable. The manually shifted handle provides metered flow to either port. Port flow is directly proportional to the movement of the lever. The tank port must go directly back to tank.

SPOOL TYPE – The spool types offered are tandem center 4-way (**T**), open center 4-way (**O**), fine metering (**M**), tandem metering (**TM**), closed center 4-way (**C**), and tandem 3-way (**T3**). (See schematics page for information on spool types)

HANDLE OPTIONS –

- **Standard enclosed lever handle (G)** pressurizes the B port when the handle is pushed towards the valve body (vertical mount).
- **Enclosed lever handle (C)** is similar to (**G**) except horizontal mount.
- **Lever handle (L)** pressurizes the B port when the handle is pushed towards the valve body.
- **Lever handle (J)** pressurizes A port when the handle is pushed towards the valve body.
- **Pilot operated (P)** is used to shift the valve from a remote location.
- **Rotary handle (H)** is used to rotate spool in or out of valve body.
- **No actuator (N)** G type spool.
- **No actuator (M)** J type spool.

SPOOL ACTION –

- **Three-position detent (D)** holds the spool in neutral and both active positions.
- **Friction detent (F1)** applies friction to the spool so that the spool does not move when the handle is released either side of neutral, a detent groove clearly indicates neutral position.
- **Spring center (S)** returns the handle to neutral when the handle is released.
- **Spring center detent (SD)** springs back to neutral from one position and is mechanically detented in the other position (flow out port A in detent).
- **Spring center friction detent (SF1)** springs back to neutral from one direction and functions similar to standard F1 in other direction (flow out port B in friction detent).
- **Spring offset (SO)** spring holds spool in one active position (P to B in offset position and neutral).
- **Spring offset (SO2)** spring holds spool in one active position (P to B in offset position, neutral and P to A).
- **Rotary friction detent (E)** applies friction to the spool as it is rotated so that the spool does not rotate when the handle is released either side of neutral, a detent groove clearly indicates neutral position.
- **Two-position detent (2D)** P to B and neutral.
- **Two-position detent (D2)** P to A and neutral.
- **Adjustable relief (R)** set to 1500 psi (103 bar) at factory.
- **Normally closed electric switch (WC)** used with (S), (F1) and (D) options only.
- **Normally open electric switch (WO)** used with (S), (F1) and (D) options only.

SPOOL SCHEMATICS:

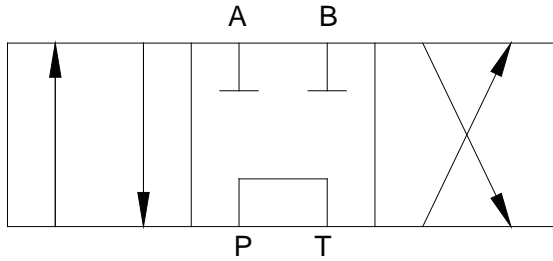

Tandem Center (T) - Powers cylinder or motor in both directions. Pump unloads to tank when spool is in neutral. Cylinder or motor blocked when spool is in neutral.

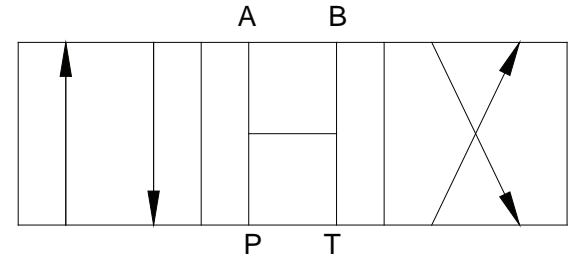

Open Center (O) - All of the ports are connected to tank when the spool is in neutral. Allows cylinder to move or motor to rotate when spool is in neutral.

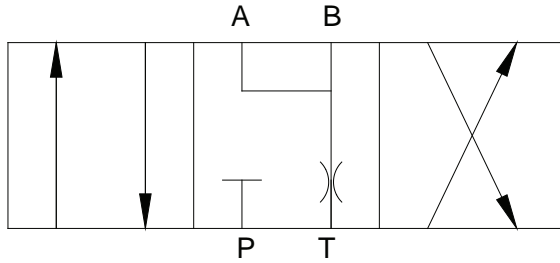

Fine Metering Spool (M) - Requires external locking valves to hold cylinder when spool is in neutral position. Extremely fine metering control. This spool requires a pressure compensated pump.

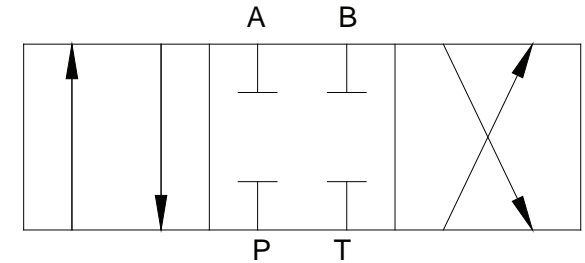

Closed Center (C) - All ports are blocked in neutral. Blocks cylinder or motor in neutral. Required for use with pressure compensated pump.

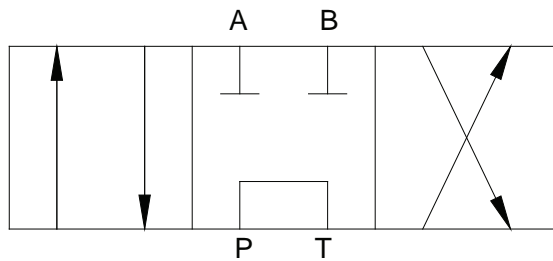

Tandem Metering Spool (TM) - Similar to (T) spool except much finer metering control. Cylinder or motor blocked in neutral and pump unloads to tank.

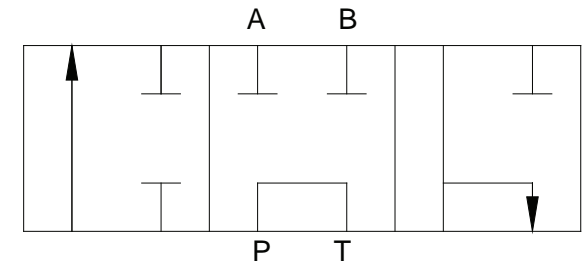

Tandem Three Way (T3) - Powers the cylinder in one direction. Pump unloads to tank when spool is in neutral, or when spool is being reversed. Cylinder is blocked when spool is in neutral. Port "B" is plugged.

AO – CREATING A MODEL CODE FOR AO’S:

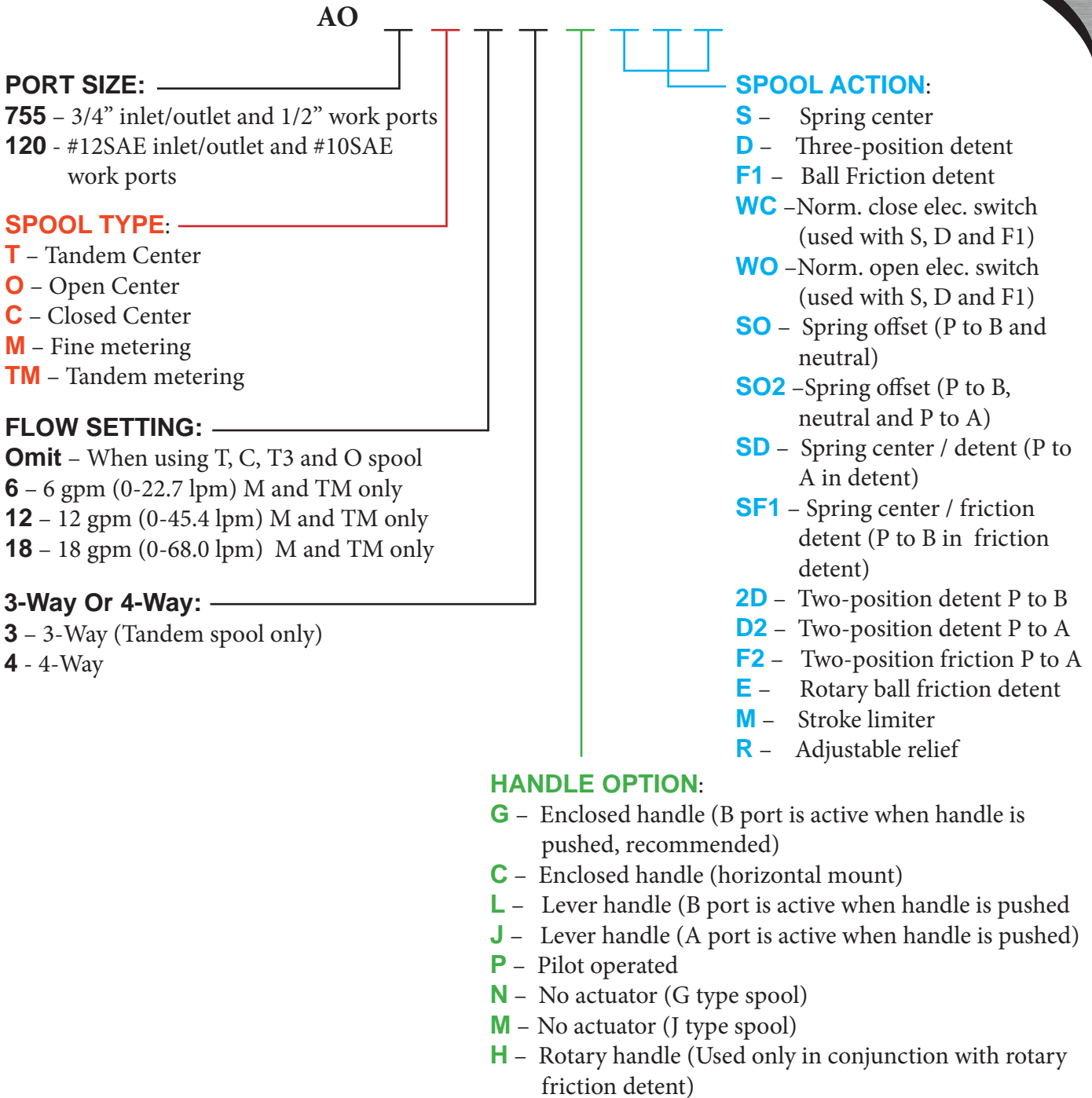

AO – EXAMPLES OF COMMON MODEL CODES:

- AO755T4GRS**.....3/4” inlet and outlet ports, 1/2” work ports, tandem center 4-way spool, G style handle, adjustable relief set at 1500 psi (103 bar) and spring centering.
- AO755O4GD**.....3/4” inlet and outlet ports, 1/2” work ports, open center 4-way spool, G style handle, and three position detent.



AO - COMPLETE LIST OF KITS:

- SDC-D**.....Three-position detent kit.
SDC-F1.....Ball friction detent.
SDC-S.....Spring centering kit.
SDC-SD.....Spring centering detent kit (P to A in detent).
SDC-SF1.....Spring center / friction detent (P to B in friction detent).
SDC-SO.....Spring offset kit (P to B in offset position and neutral).
SDC-SO2.....Spring offset kit (P to B in offset position, neutral and P to A)

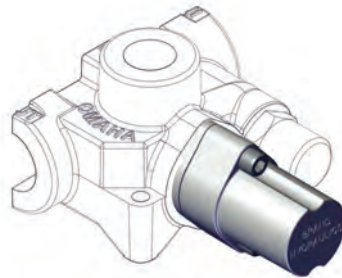
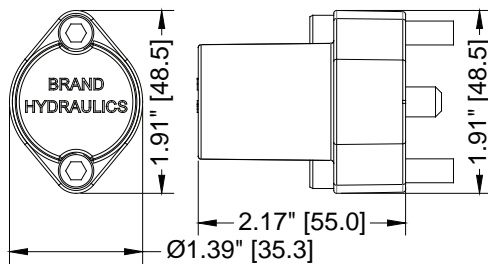

External dimensions are the same for all kits listed above.

- SDC-SWC**.....Spring centering kit with normally closed electric switch.
SDC-SWO.....Spring centering kit with normally open electric switch.

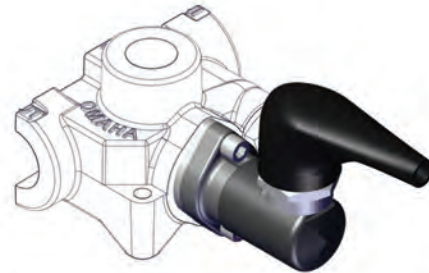
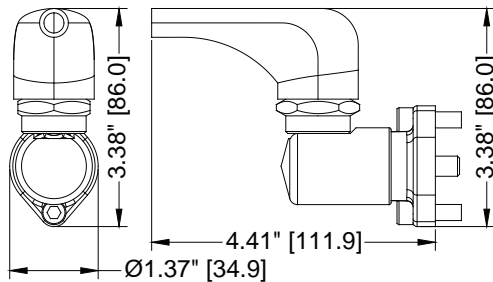

External dimensions are the same for all kits listed above.

- SDC-WC**.....Three-position detent kit with normally closed electric switch.
SDC-WO.....Three-position detent kit with normally open electric switch.
SDC-F1WC.....Ball friction detent with normally closed electric switch.
SDC-F1WO.....Ball friction detent with normally open electric switch.

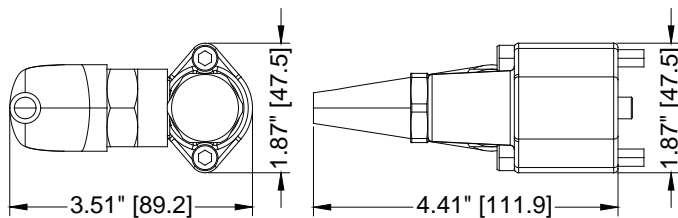

External dimensions are the same for all kits listed above.

AO – COMPLETE LIST OF KITS: (continued)

SDC-HG.....G style handle kit.

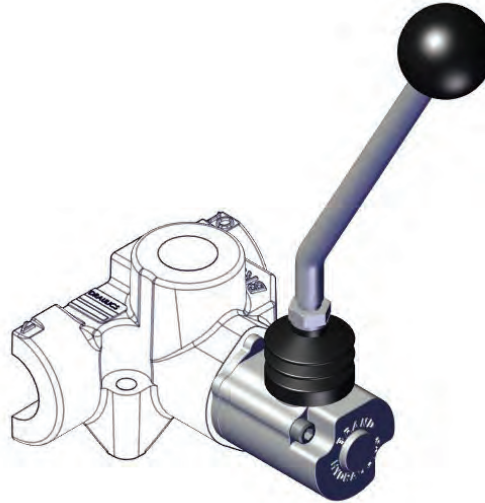
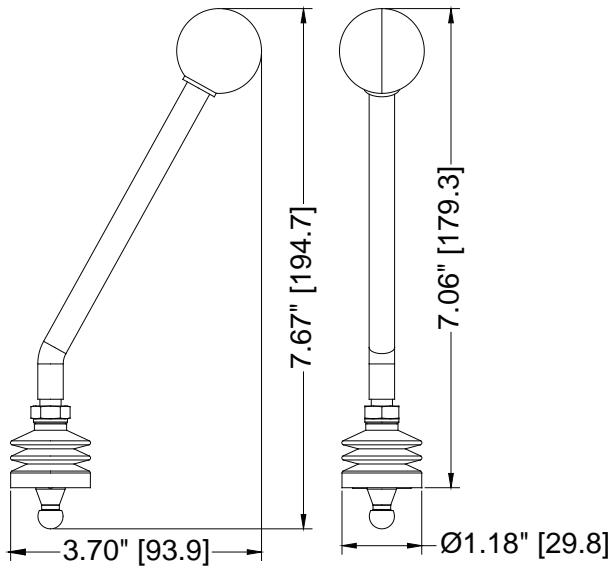

SDC-HJ.....J style handle kit.

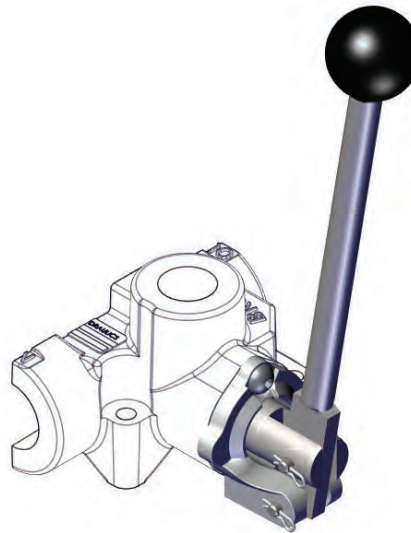
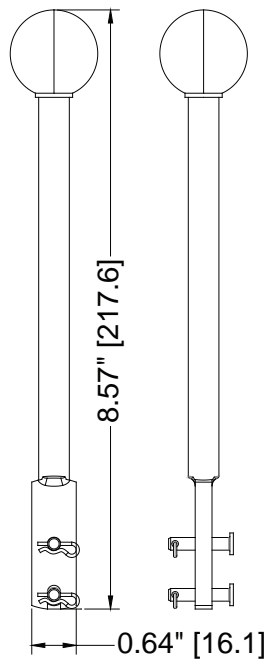

AO - COMPLETE LIST OF KITS: (continued)

SDC-HL.....L style handle kit.

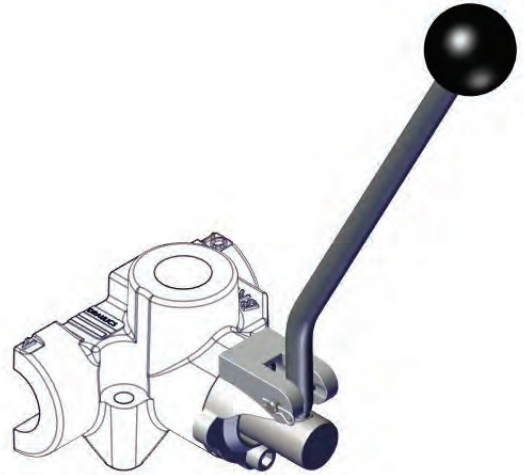
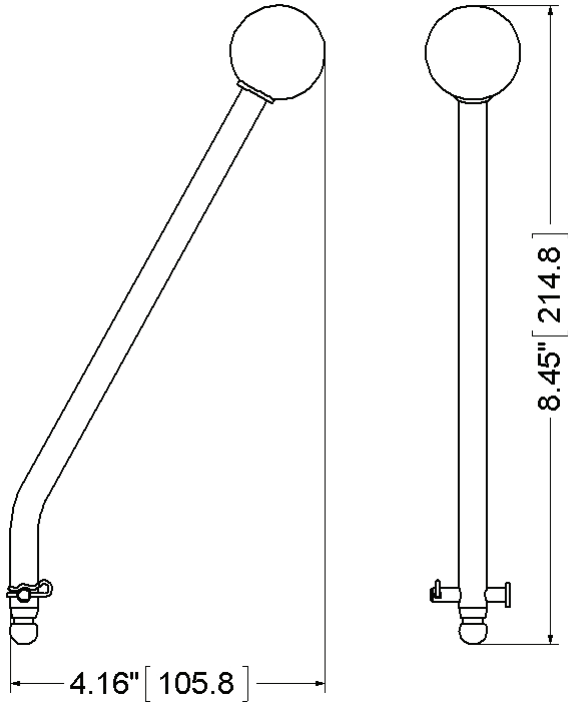

SDC-K.....Seal kit for SDC-K.

AO – FLOW AND PRESSURE INFO:

Pressure Drop VS. Flow

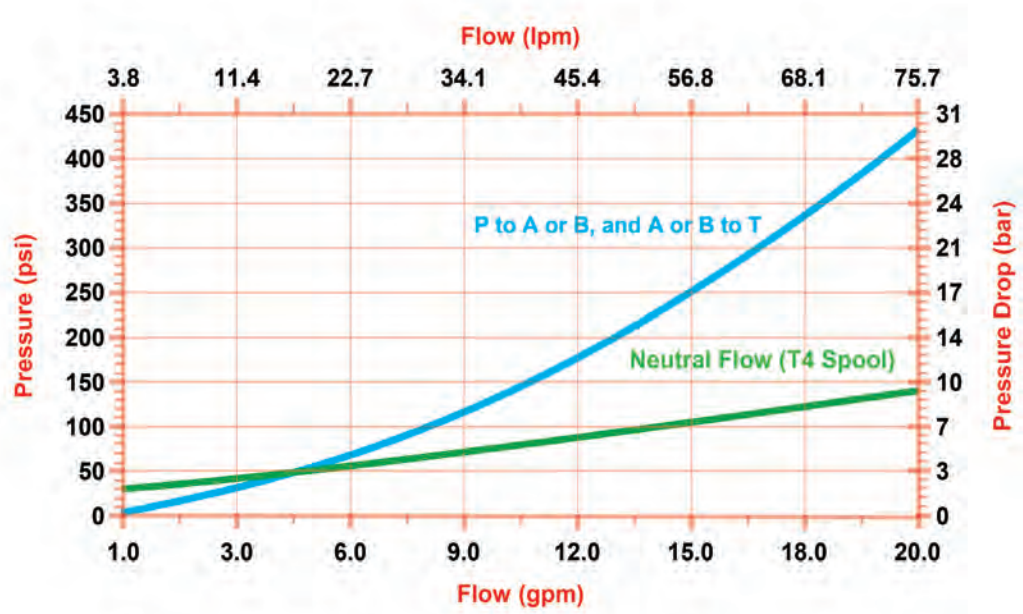

Pressure VS. Flow for AO Relief (R)

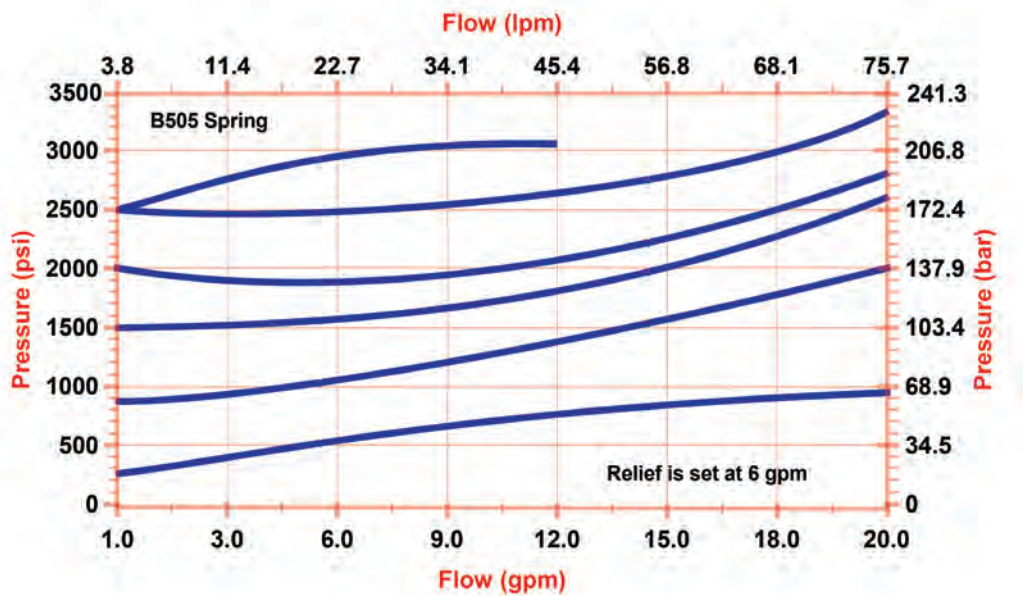

DIMENSIONAL DATA (AO120T4GRS SHOWN): inches & [millimeters]

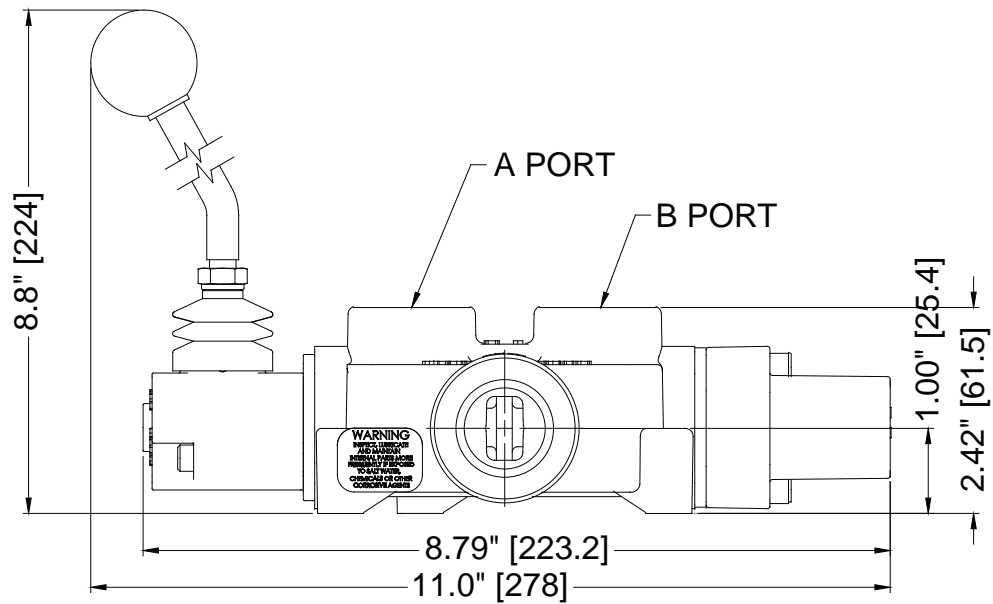

**ADJUSTABLE RELIEF
(1500 PSI (103 BAR) FACTORY SETTING)**

