



**SNOL**  
Innovation in  
Performance and Economy

**SNR - Industry**





## SNOL oil-lubricated plummer block for rolling bearings

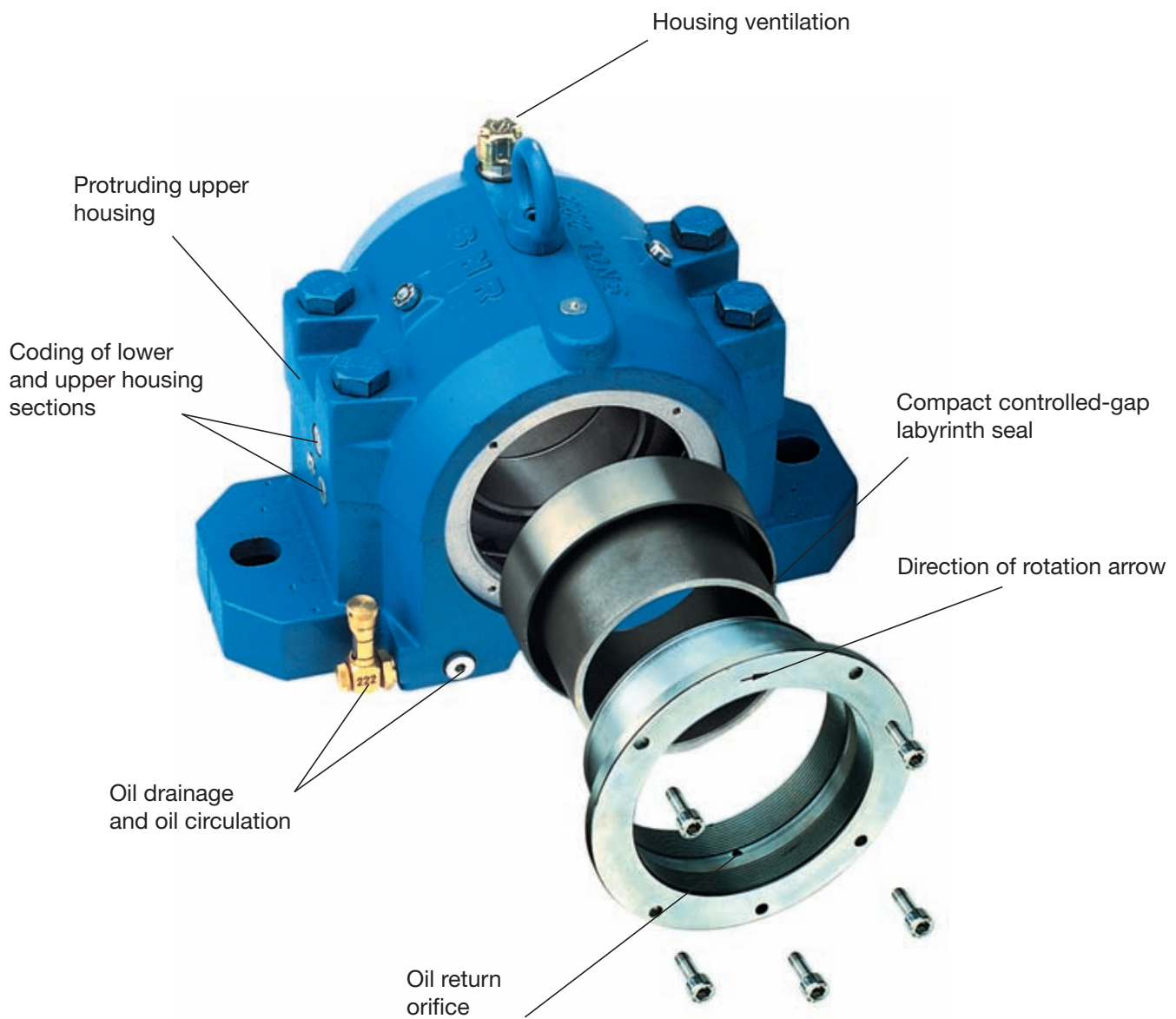

## SNOL oil-lubricated plummer block for rolling bearings excels on account of its functionality at low weights.

### ***Protruding upper housing***

To ensure that moisture cannot penetrate into the housing through the mold seam, the upper housing section juts out over the lower section. This prevents condensation from entering the bearing housing. For several years now SNR has achieved excellent results with this system in grease-lubricated SNB housings.

### ***Coding of lower and upper housing sections***

Both upper and lower housing sections are given the same coding label to prevent mixing when assembling more than one plummer block.

### ***Oil drainage and oil circulation***

The SNOL comes with four oil-drainage bores on the side of the housing. These holes and the four holes at the front can also be used for oil circulation.

### ***Alternative oil-drainage options***

In the lower section of the housing a position has been marked with a graining with which an additional oil-drainage bore can be made.

### ***Housing ventilation***

The housing is ventilated under operation using the latest technology. Contamination such as sand and dust are prevented from entering the housing. When filling the housing the ventilator has to be removed first.

### ***Compact controlled-gap labyrinth seal***

Thanks to our long-standing experience in the area of oil-lubricated bearing housing design we have created a reliable and effective sealing system.

Oil leakage and moisture penetration are thus prevented through the use of various sealing threads in the side cover.

### ***Direction of rotation arrow***

As the function of the sealing threads are dependent on the direction of rotation, they are all marked with direction of rotation arrows – with the exception of the interchangeable lid.

### ***Oil return orifice***

This orifice enables any oil which has penetrated this far to be returned to the interior of the housing.



## SNOL oil-lubricated plummer block for rolling bearings

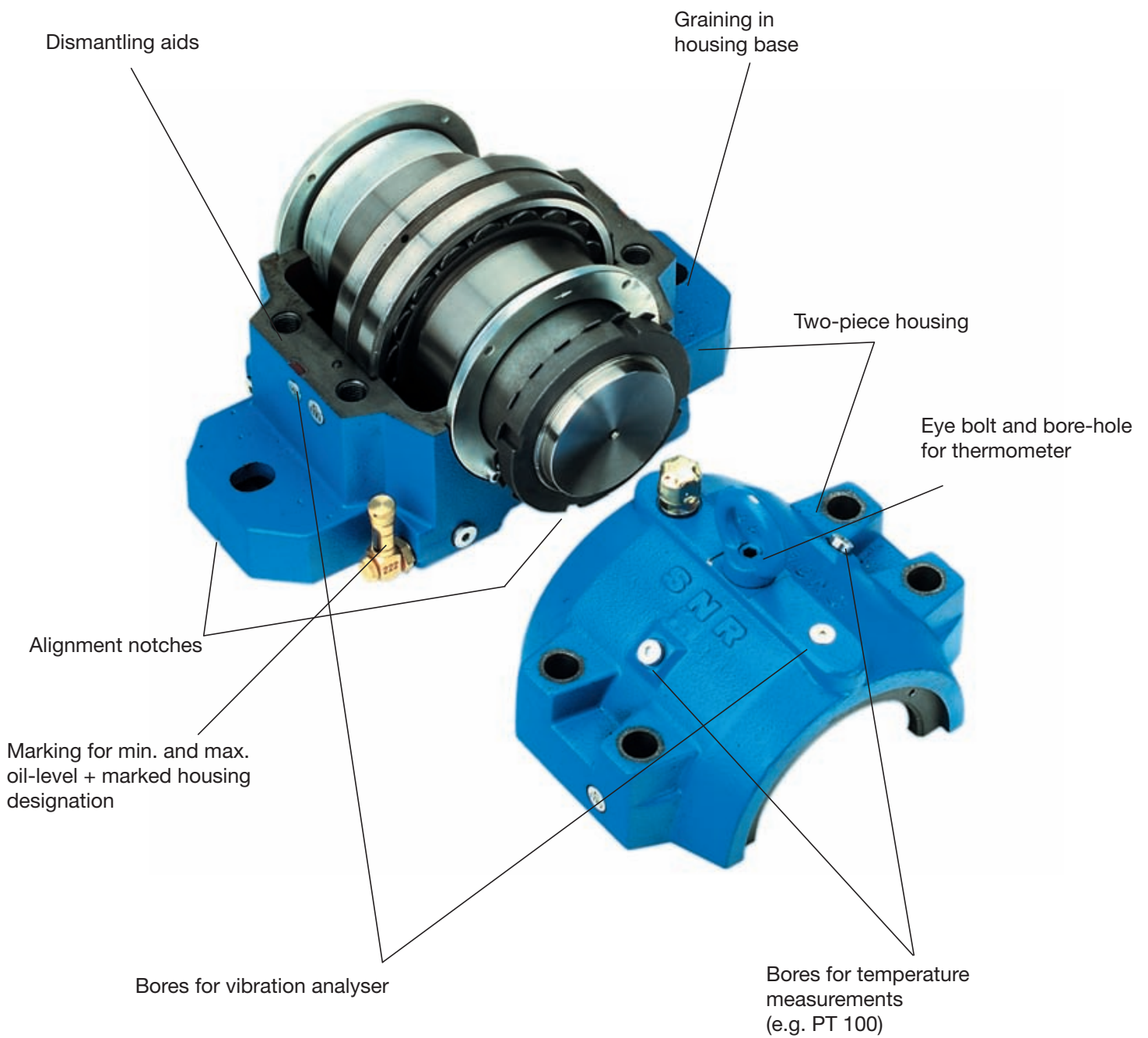

## SNOL oil-lubricated plummer block for rolling bearings

### **Graining in housing base**

Graining has been provided in the base on both sides of the housing in order to be able to locate the housing to the bottom section or to mount it using four instead of two bolts (e.g. to an I-beam) .

### **Dismantling aids**

In order to make it easier to separate the housing sections, small recesses have been cast in both sides of the lower section.

### **Alignment notches in base**

SNR has cast markings on all four sides of the housing in the base in order to make it easier to align the housing when assembling it.

### **Oil-level indicator**

The individual minimum and maximum oil-level markings made on the oil-level indicator enable the oil level to be easily checked during operation.

### **Engraved housing identification**

The oil-level indicators can be assigned to each individual SNOL, as each display is marked with the respective housing model. Thus in case of replacement it is a simple task to determine which display is at issue.

### **Corrosion protection**

The housing shell is painted on both the inside and outside. For the various detachable components SNR has used elements which are rust proof, or corrosion protected by means of a dual chromate coating.

### **Two-piece housing**

The housing has been split in two to facilitate an ideal mounting process. The pins inserted into the interface serve to prevent any incorrect mounting of the upper and lower sections. The upper section is bolted to the lower section using four hexagonal screws and tightened to a specified torque.

### **Eye bolt and temperature measurement**

To better facilitate ease of handling SNR has mounted an eye bolt onto the housing from a size of SNOL 220 and larger. If this is removed, a temperature gauge (e.g. straight-enclosed scale thermometer) can be screwed onto the housing.

### **Bores for vibration analyser and temperature measurements**

Vibration analysers can be mounted at the designated positions either horizontally or vertically, in order to measure vibrations. The gate system mounted to the upper section can also be used to install temperature gauges (e.g. PT 100). These devices also serve to provide valuable information on oil and bearing conditions.



## SNOL oil-lubricated plummer block for rolling bearings

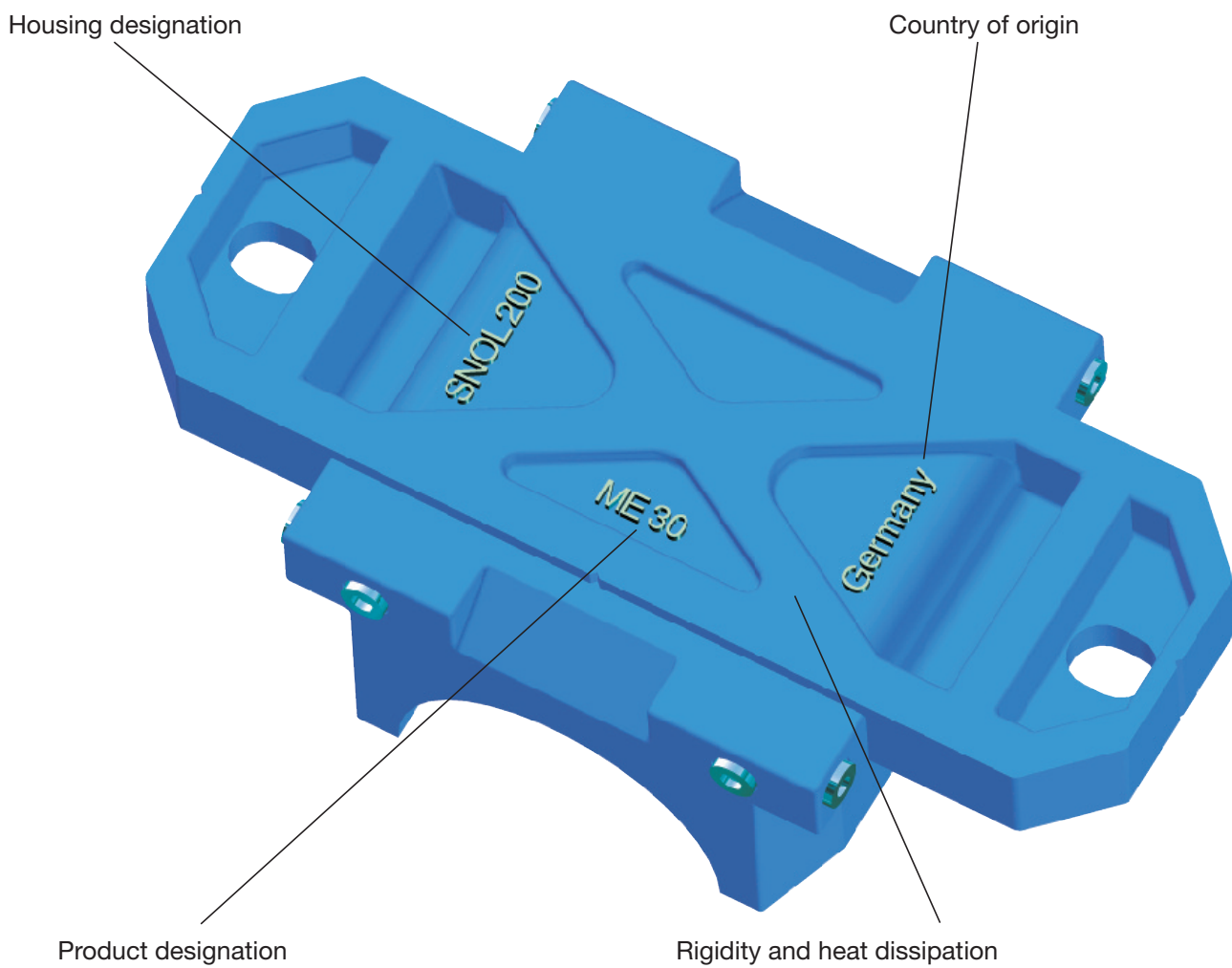

## SNOL oil-lubricated plummer block for rolling bearings

### **Housing designation**

All SNOL housings are marked below the base with the series and size of the housing.

### **Country of origin**

SNR bearing housings are developed and produced in Germany.

### **Rigidity and heat dissipation**

Tests performed have demonstrated the efficiency of the SNOL series' optimized base design with regard to housing rigidity and dissipation of operating heat.

### **Product designation**

For internal purposes SNR has provided all housings with a code number.

**SNOL housings in the following most important sizes can be interchanged with the familiar SN plummer blocks for rolling bearings;**

- shaft diameter
- shaft center height
- spacing of holes for fastening bolts

We have also endeavoured to comply with the SN housings series for the other dimensions.

With the following exceptions this is generally the case:

1. Due to the fact that a large oil volume is critical for oil-lubricated bearing housings and the sealing system is more complicated than that for grease-lubricated housings, the width of the SNOL has been enlarged.
2. In individual cases, the overall height of the housing has to be adapted to the requirements of the specified measuring equipment.

**More detailed information is available in the following lists of dimensions on pages 8 and 9.**



## SNOL oil-lubricated plummer block for rolling bearings

Excellent performance under light loads

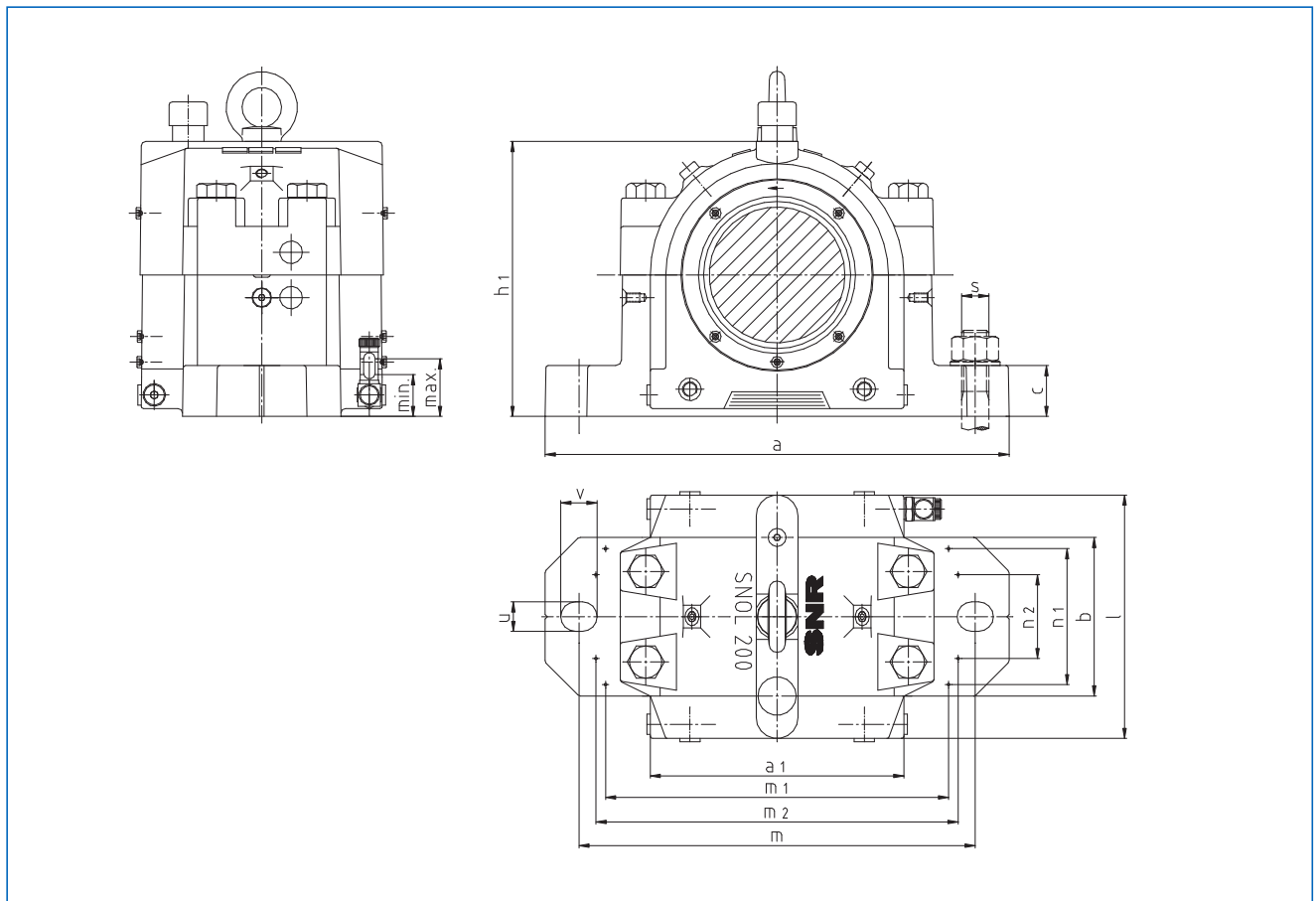

Dimensions in mm

d	d <sub>1</sub> min.	d <sub>2</sub>	B	D	a	a <sub>1</sub>	b	c	g	h	h <sub>1</sub>	l	l <sub>1</sub>	m	m <sub>1</sub>	m <sub>2</sub>	n <sub>1</sub>	n <sub>2</sub>	n <sub>3</sub>	s	u	v	w <sub>1</sub>	w <sub>2</sub>
60	70	M 60 x 2	28	110	255	140	80	30	40	70	139	140	162	210	170	200	52	40	90	M16	18	23	94	29
70	80	M 70 x 2	31	125	275	150	90	30	44	80	158	150	173	230	190	220	60	48	100	M16	18	23	101	32
80	90	M 80 x 2	33	140	315	155	95	32	50	95	179	155	183	260	210	260	65	52	100	M20	22	27	107	36
90	103	M 90 x 2	40	160	345	185	115	35	65	100	196	185	220	290	240	280	95	58	120	M20	22	27	129	41
100	113	M100 x 2	46	180	380	202	125	40	70	112	219	200	234	320	270	300	105	66	130	M24	26	32	139	46
110	123	M110 x 2	53	200	410	224	140	45	80	125	243	215	252	350	303	320	120	74	140	M24	26	32	151	51
120	138	M120 x 2	58	215	410	244	140	45	86	140	271	225	263	350	313	330	120	74	140	M24	26	32	159	55
130	148	M130 x 2	64	230	445	250	145	50	90	150	290	230	266	380	340	370	125	80	160	M24	28	35	163	59
140	160	M140 x 2	68	250	500	270	160	50	98	150	302	250	290	420	360	400	140	92	170	M30	35	42	177	62

The construction of the plummer blocks is constantly developing.  
For this reason we reserve for ourselves the introduction of technical improvement at any time.



## SNOL oil-lubricated plummer block for rolling bearings

Excellent performance under light loads

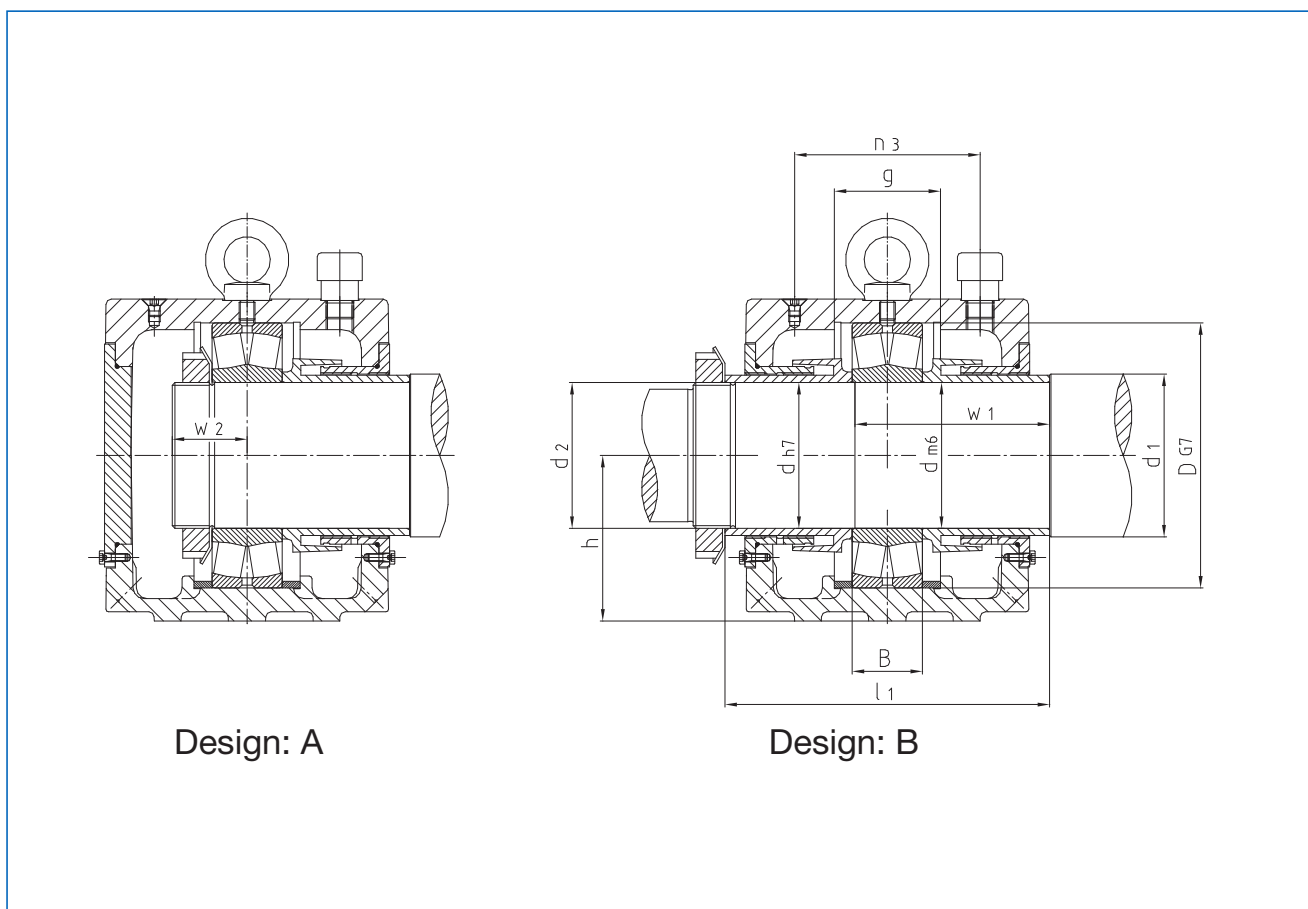

### Parts of application

Code	Bearing	Locating rings	Locknuts	Lock washers	Oil-level	Oil-quantity	Weight
					in operation	incl. bearing	incl. bearing
					min. - max.	approx. ml	approx. kg
SNOL 212	22212 J30	FR 110 / 6	KM 12	MB 12	22 - 28	100	-
SNOL 214	22214 J30	FR 125 / 6.5	KM 14	MB 14	25 - 31	145	-
SNOL 216	22216 J30	FR 140 / 8.5	KM 16	MB 16	34 - 39.5	180	18.5
SNOL 218	22218 J30	FR 160 / 12.5	KM 18	MB 18	31.5 - 36.5	250	-
SNOL 220	22220 J30	FR 180 / 12	KM 20	MB 20	34 - 41	360	39
SNOL 222	22222 J30	FR 200 / 13.5	KM 22	MB 22	37 - 51	580	50
SNOL 224	22224 J30	FR 215 / 14	KM 24	MB 24	45 - 53	620	65.5
SNOL 226	22226 J30	FR 230 / 13	KM 26	MB 26	49 - 58	650	-
SNOL 228	22228 J30	FR 250 / 15	KM 28	MB 28	40 - 56	730	-

It is also possible to deliver SNR plummer blocks as mounted units with shaft.  
In this case, we would require the dimensions of your contacting parts.



## SNOL oil-lubricated plummer block for rolling bearings

---

SNR is not only an expert in all matters relating to anti-friction bearing technology, but also demonstrates with this housing series that successful industrial design is possible in the area of transmission engineering.

### **The main advantages once again at a glance:**

- interchangeability – in most cases with the grease-lubricated SNB plummer blocks for rolling bearings
- significantly greater oil volume than in correspondingly-equipped SN housings
- optimized sealing system
- considerably more cost effective than previous oil-bearing housings
- versatile number of connection options for various measuring and monitoring equipment

## Notes

---

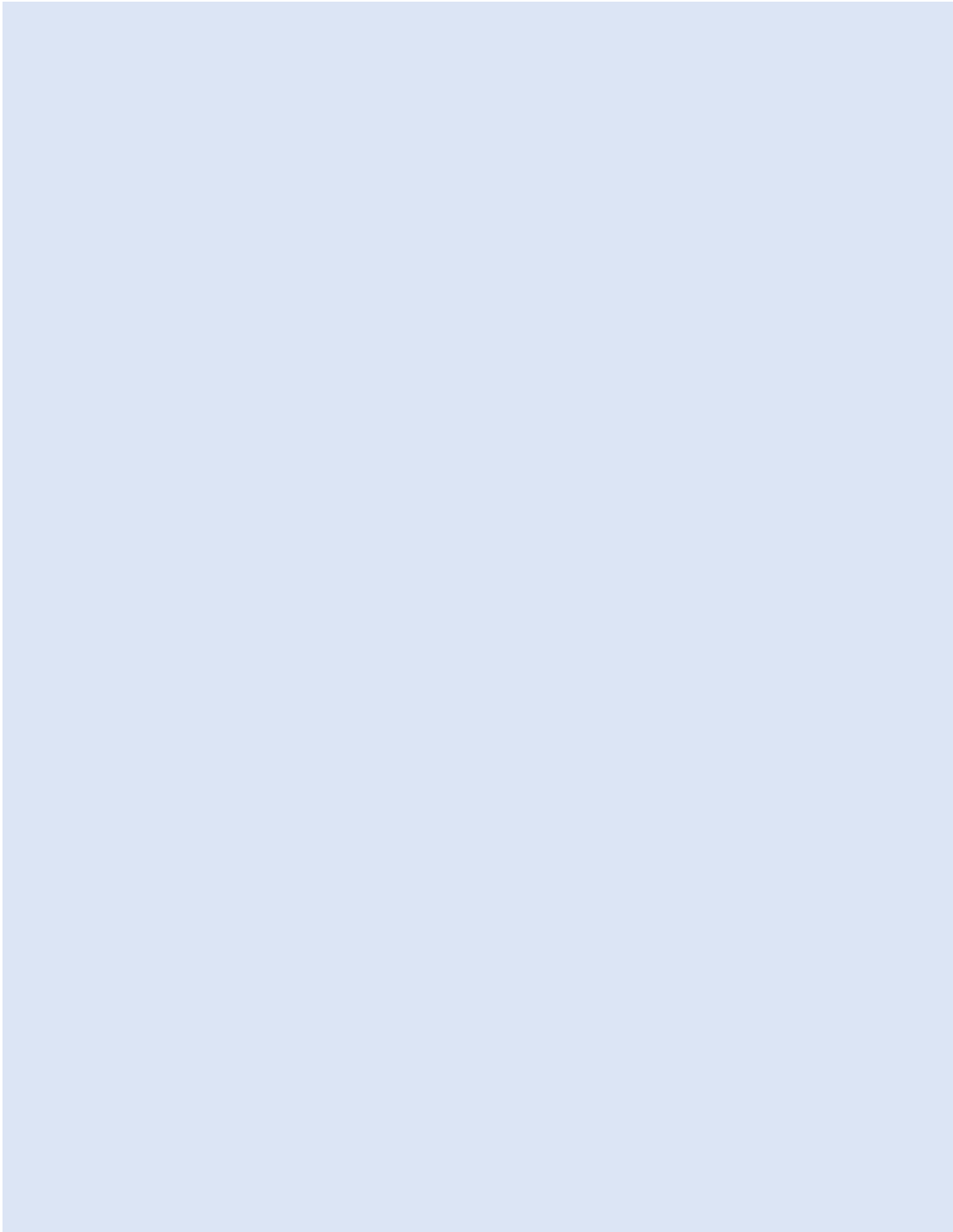

## Europe

### FRANCE

SNR Paris 40, rue Jean Bleuzen  
B.P. 49  
92174 Vanves Cedex  
Tél. 01 40 93 66 00  
Fax. 01 40 93 66 10

SNR Logistique 9, avenue Léon Harmel  
92160 Antony  
Tél. 01 46 11 66 50  
Fax. 01 46 11 66 66

SNR Bordeaux 1, rue du Golf - B.P. 173  
33708 Merignac Cedex  
Tél. 05 56 34 69 80  
Fax. 05 56 34 69 81

SNR Lyon Europe\* Le Florentin - 71, chemin  
du Moulin Carron - B.P. 8  
69570 Dardilly  
Tél. 04 78 66 68 00  
Fax. 04 78 66 68 20

SNR Nancy Europe\* 3, allée Forêt de la Reine  
Parc technologique Brabois  
54500 Vandœuvre  
Tél. 03 83 44 64 00  
Fax. 03 83 44 02 31

### DEUTSCHLAND

SNR WÄLZLAGER GMBH www.snr.de  
40472 Düsseldorf Wahlerstraße 6  
40437 Düsseldorf  
Postfach 33 04 10  
Tél. (0211) 6 58 06-0  
Fax. (0211) 6 58 88 86

33719 Bielefeld Friedrich-Hagemann-Str.66  
33701 Bielefeld  
Postfach 17 01 45  
Tél. (0521) 9 24 00-0  
Fax. (0521) 9 24 00 90

70597 Stuttgart Tränkestraße 7  
70574 Stuttgart  
Postfach 70 04 16  
Tél. (0711) 9 00 64-0  
Fax. (0711) 9 00 64 99

### UNITED KINGDOM

NADELLA UK www.nadella.uk.com  
Coventry Progress close  
Leofric Business Park  
Binley - Coventry CV3 2TF  
Tél. 24 7629 6900  
Fax. 24 7629 6991

### ITALIA

SNR Italia  
Milano Via Keplero, 5  
20019 Settimo  
Milanese (MI)  
Tel. (02) 33 55 21  
Fax (02) 33 50 06 56

Bologna Via E.Zago, 2/2  
40128 Bologna  
Tel. (051) 36 79 46  
(051) 36 29 78  
Fax (051) 36 85 38

### ESPAÑA

SNR Rodamientos Hispania  
Madrid C/ Llanos de Jerez, 22  
Polígono Industrial  
28820 Coslada  
Tél. 91 671 89 13  
Fax. 91 673 65 48

### BELGIQUE

NADELLA  
Bruxelles Langveldpark  
Basteleusstraat 2-4-6 unit 9  
1600 Sint-Pieters-Leeuw  
Tél. 02 523 81 92  
Fax. 02 522 52 57

### \*EUROPE

(Subsidiaries excepted)  
SNR Nancy - Europe : Benelux - Suisse - Autriche  
SNR Lyon - Europe : Other Countries Fax. 04 78 66 68 21

## Amériques / Americas

### USA

SNR Bearings USA www.snrbearings.com  
Atlanta 4600 K Highlands Pkwy  
Smyrna, G.A. 30082  
Tél. (770) 435-2818  
(800) 232-1717  
Fax. (800) 742-5215

### LATIN AMERICA

SNR Argentina  
Buenos-Aires Viamonte 1145 - Piso 11  
1053 Buenos-Aires  
Tél. (54) 11-4 372-1272  
Fax. (54) 11-4 372-0088

## Autres pays / Other countries

### SNR Intermondial (Overseas)

Annecy 18, rue du Val-Vert  
74600 Seynod  
France  
Tél. (33) 4 50 65 96 00/01/02  
Fax. (33) 4 50 65 96 15

### MAROC

SNR Maroc e-mail : snrroulements@snrmaroc.com  
Casablanca 17, rue Buzancy  
Belvédère  
Casablanca 20300  
Tél. (212) 02 2 241 530  
Fax. (212) 02 2 241 532  
(212) 02 2 241 542

