

Sensor control

TF 6-100 and TF 6-200 Contact temperature sensor



The temperature sensors of the TF 6 series are used when ever it is reasonable to detect the temperature in the material instead of measuring it's surface temperature. The TF 6 temperature sensor can be used in batch scales or silos, but also on belt conveyors as well. The holder of the thermo element is made of tempered stainless steel, guaranteeing best results even in longer measuring periods. On demand, we will also offer you the device with a ceramics covering.

A) CONVEYOR INSTALLATION

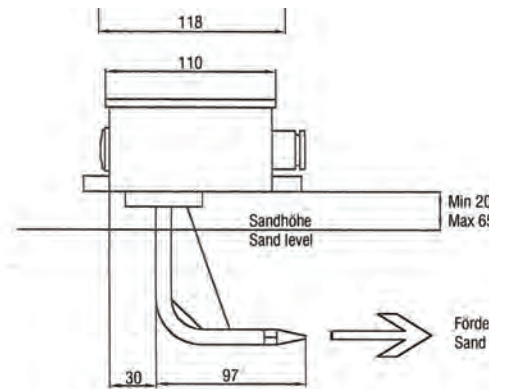
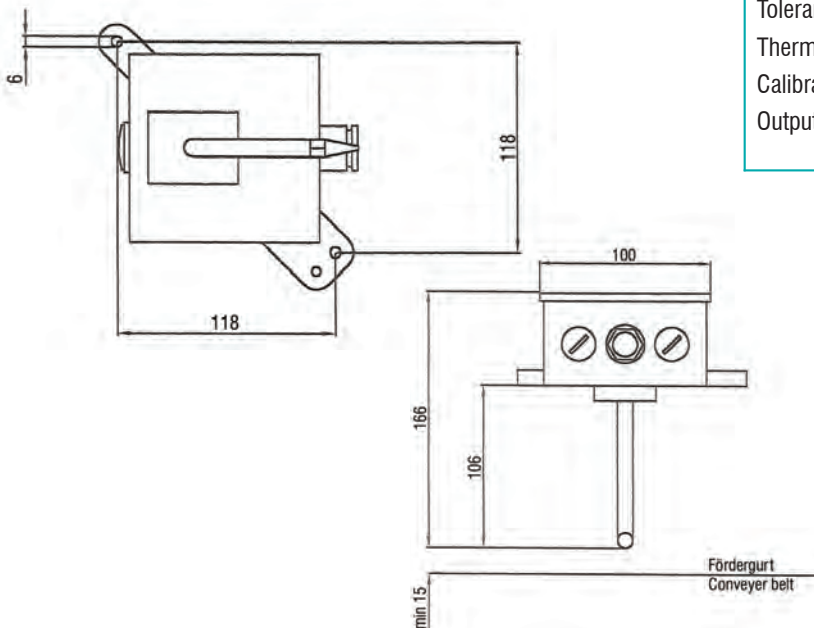

Technical Data:

Temperature	100°C / 200°C
Tolerance max.	+/- 1,5%
Thermo unit	Pt 100
Calibration	0-100°C / 0-200°C
Output signal	4-20mA

B) BATCH SCALE INSTALLATION

