



High-Performance Bolt Heaters

Boron Nitrid Technology

TIGHTENING / UNTIGHTENING OF DRILLED BOLTS THROUGH THERMAL EXPANSION



Smaller equipment

Less space, weight, heat loss, cost saving, reduced thermal inertia



Increased Productivity

More heat in less time for shorter production cycles



High Temperature

Longer heater life in extreme conditions, very high temperatures



Power control panels and connecting cables available on demand



Rev 1.1

www.cetal.com





CETAL bolt heaters reduce the nut tightening and untightening time by heating while improving the safety of operators and heated material.

High performance through boron nitrid insulation

The use of boron nitrid as insulation allows to concentrate a lot of energy in a small space. The power is transmitted by radiation.

With this technology, high temperatures can be obtained in a short time, thus reducing to a few minutes the nut tightening/untightening time.

Applications

- Tightening/untightening of drilled bolts through thermal expansion
- Maintenance of turbine engines

Advantages

- Very short heating time
- Heating to approx. 350 °C (depending on the bolt material)
- Easy handling
 - one operator per machine
 - one power outlet per bolt heater
- Significantly reduces the assembling/ deassembling time of large forged and cast-iron parts
- Capacity to heat only the central part of the bolt
- Long lifetime: 10 000 cycles
- Workstation safety through low voltage < 50 V

Industrial sectors

- Shipyards
- Thermal power stations
- Metallurgy
- ...

Design

The bolt heaters are designed according to specifications using standard tube diameters.

Length and power are defined according to the bolt to be heated (size, Ø of drilling, mounting tolerance).

The bolt heaters can be supplied with 24 V (BT plug), 110 V, 230 V or other voltage.

The heating part of the bolt heaters is indicated through small machined grooves. To avoid incorrect installation, a positioning ring helps identifying the active zone.

The CETAL expertise

After customer specification analysis, our engineers will drive you to the best solution for your process.



Bolt heater application – Tightening through thermal expansion

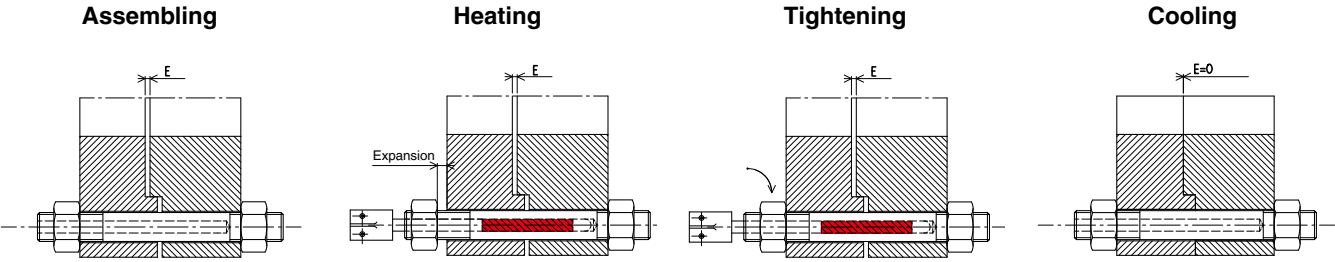

Main advantages of Boron Nitrid technology

- Temperature gradient improved by 10 compared to Magnesia
- Heating 100% homogeneous (Straight wire)
- Medium voltage
- No leakage current at high temperature
- Boron Nitrid heating elements are smaller and lighter: they save space and are easy to handle

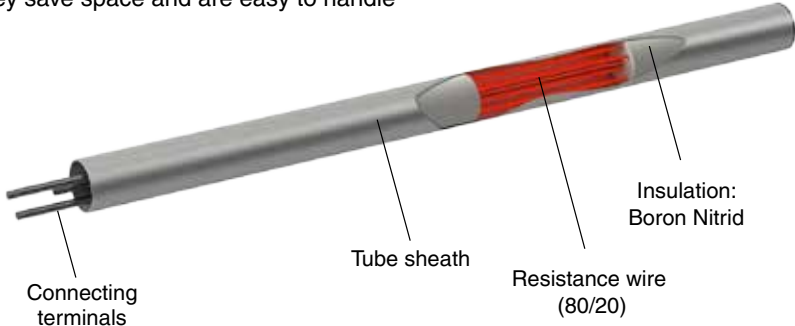

Benefit from the CETAL advantages!



Design and manufacturing experts since 50 years!



Calculation and design tools specifically developed for industrial heating applications



End-to-end control of design and production chain for products which suit your process perfectly



Benefit from the CETAL know-how to optimize your process and reduce costs!

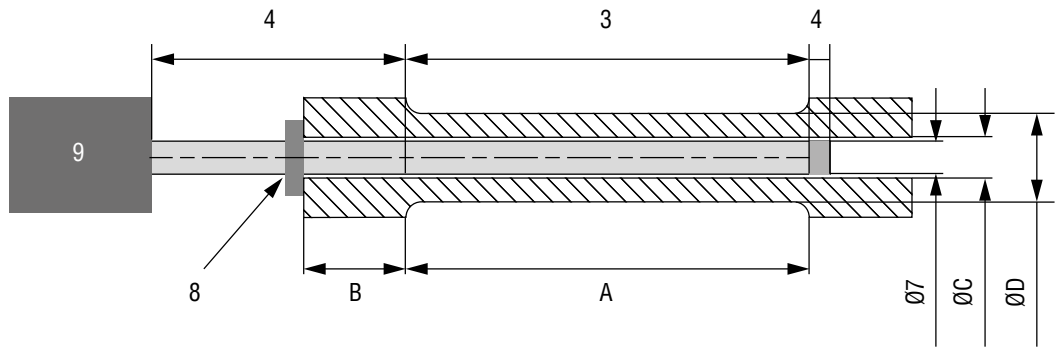

Design of your bolt heater

Input data

- Bolt material, ideally incl. specific heat and expansion coefficient
- Thinned length of the bolt (A)
- Length of bolt end (B)
- Bolt drilling diameter (C)
- Outer diameter of the thinned length (D)
- Straight or angled?
- Power (W)
- Voltage (V) 1PH or 3PH
- Supply, connecting box
- Total length (including 30-40 mm cold length)
- Power control panel and cables? (please specify the cable length)

CETAL thermal design and offer

Design procedure to optimize your product

1. Power
2. Voltage
3. Heating length
4. Cold length
5. Total length
6. Watt density (W/cm^2)
7. Material / Tube diameter
8. Positioning ring
9. Type of plug or connecting box
10. Power control panel
11. Cables
12. Quotation: price and delivery time

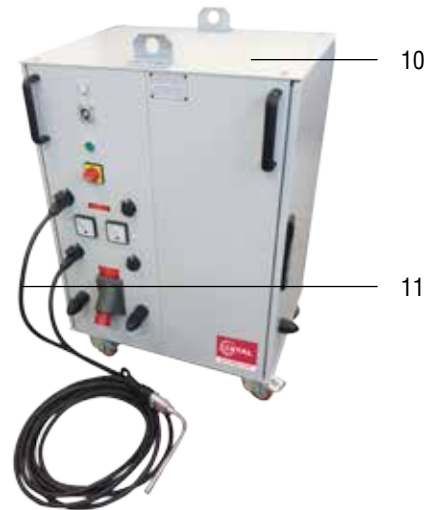

Données techniques

Tube materials

- Inox AISI 316L (1.4404)
- Others on request

Tube / bolt diameters (mm)

Ø bolt heater	Ø H11 bolt
10.70	11
11.70	12
12.20	12.5
15.70	16
17.70	18
19.70	20
21.65	22
24.60	25
25.60	26
29.60	30

Other diameters on request

Electrical

- Voltage: VAC or VCC
- Cabling according to main voltage VAC/VCC
1PH + N or 3PH
- Power: < 10 000 W (higher on request)

Connection / Connection box

- **24 V or 48 V plug**

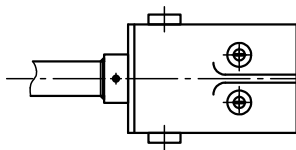

- Female aluminum plug
- Male plug, plastic, with cable
- Thermal grease

- **Box filled with resin, 230-400 V**



- With HO7RNF or silicone cable
- Thermal grease

- **Box with handle, 230-400 V**

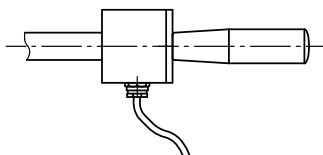

- With or without LED
- With HO7RNF or silicone cable
- Thermal grease

- **Other connection boxes on request**
(e. g. RATEAU connection box),
can be supplied with simple threaded rods

Standard documentation

- EU Certificate of Compliance
- Instruction manual

On-request documentation

- Certificate of conformity to the order
- Supplied according to directives and standard
- Material certificate 3.1 acc. to NF EN 10204

Certifications (if requested)

- According to standard to comply with
- EAC CU&TR



Options

- **Detachable cable**
(except for box filled with resin)
- **Other connection boxes on request**
- **Power control panels**
 - Power 5, 10, 15, 20 KVA
 - 24 V / 48 V, primary 230 V or 400 V
 - 110 V / 230 V on request



All CETAL products can be adapted to your specifications.

Contact us!



Flange immersion heaters



Screw plug immersion heaters



Removable immersion heaters



Circulation heaters

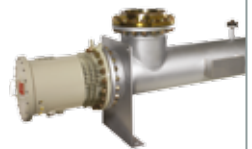

Cast line heaters



Air duct heaters



Industrial convectors



Formed elements



Cast elements



Ribbed heaters

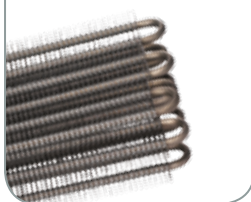

Anti-condensation heating elements



Bolt heaters



Power control panels – Standard range

