

NFE 44121 - DIN 24 256 - ISO 2858 - ISO 5199

Generalities

The horizontal, single stage centrifugal pumps of NI range are intended for the pumping of liquids that required Stainless Steel construction in the most various industrial applications.

NI pumps range offer flow rates up to 300 m³/h (1320 US gpm) and a discharge head up to 100 mcl (327,50 ft).

Normalized

The dimensions and characteristics of NI pumps correspond to standards NFE 44121 - DIN 24256 - ISO 2858 and 5199.

Suction and discharge flanges correspond to standards NFE 29-203 – DIN 2533 – ISO PN 16



Sealings

NI pumps can be mounted with normalised mechanical seals, single or double depending on liquid pumped. For application with magnetic drive, refer to brochure NI-M.

ATEX Conformity



For the EC zone, NI pumps are available certified as per ATEX 94/9/CE.

II 2/3 GcT4 (others on demand).

Voluntary certification INERIS 06 ATEX 3005X.

Construction

All parts in contact with pumped liquid are made of Stainless Steel.

- X2 Cr Ni Mo 17-12-2 (AISI 316L).

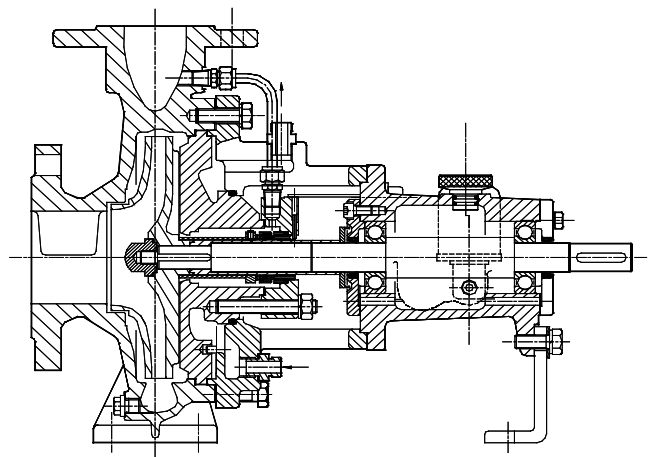

Diagrams

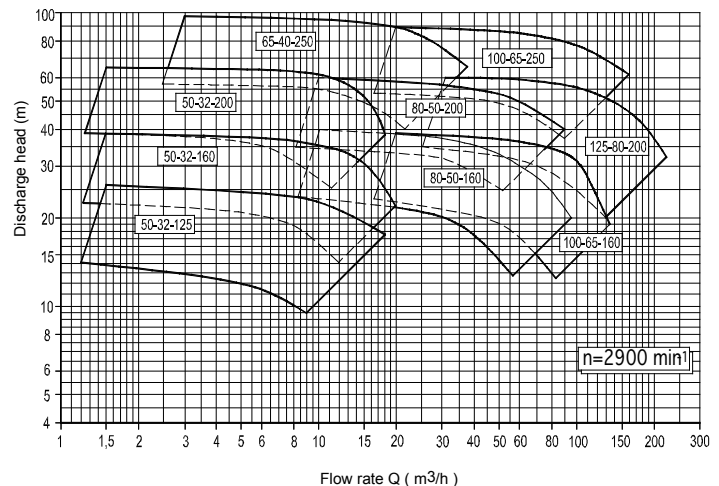
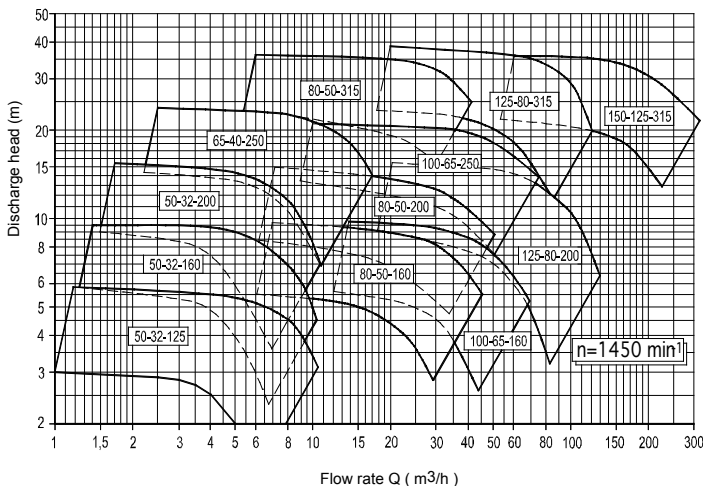

OVERVIEW OF GROUP

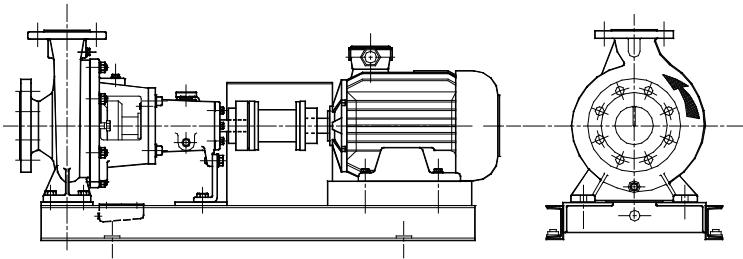

BARE SHAFT DIMENSIONAL DRAWING

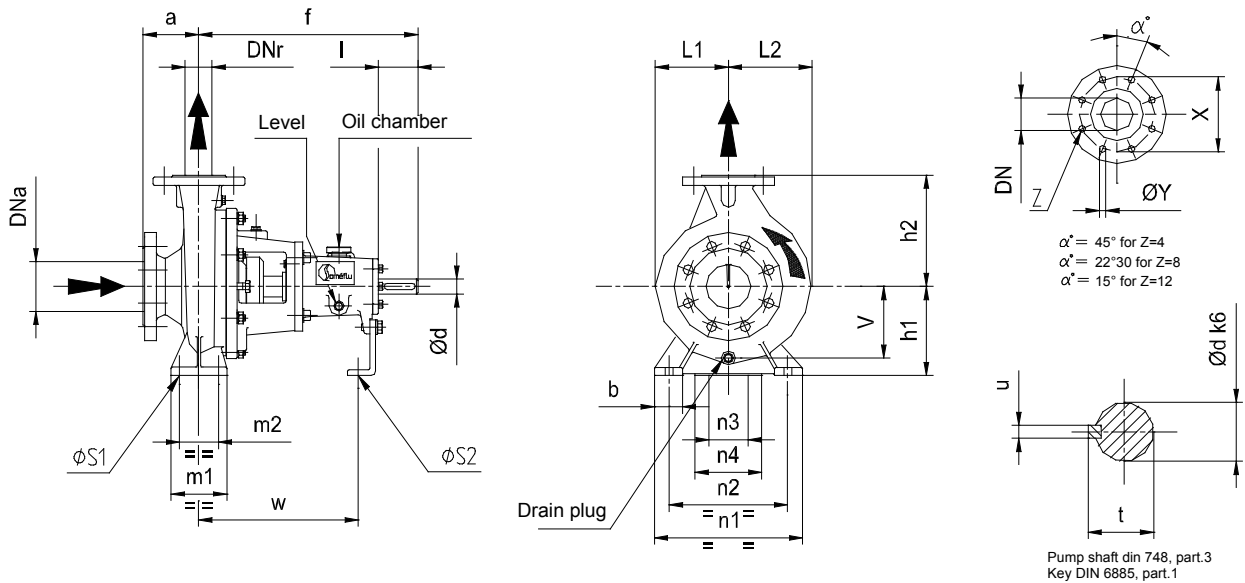

TYPE	Discharge flanges				Suction flanges				Pumps dimensions								Supports dimensions								Shaft end			Weight in Kg		
	DNr	X	Y	Z	DNa	X	Y	Z	a	f	h1	h2	L1	L2	V	b	m1	m2	n1	n2	n3	n4	s1	s2	w	d	l		t	u
50-32-125	32	100	18	4	50	125	18	4	80	385	112	140	94	94	88	50	100	70	190	140	110	160	14	14	285	24	50	26,9	8	38
50-32-160	32	100	18	4	50	125	18	4	80	385	132	160	105	113	97	50	100	70	240	190	110	160	14	14	285	24	50	26,9	8	40
50-32-200	32	100	18	4	50	125	18	4	80	385	160	180	130	130	117	50	100	70	240	190	110	160	14	14	285	24	50	26,9	8	47
65-40-250	40	110	18	4	65	145	18	4	100	500	180	225	159	167	150	65	125	95	320	250	110	160	14	14	370	32	80	35,3	10	85
80-50-160	50	125	18	4	80	160	18	8	100	385	160	180	117	140	115	50	100	70	265	212	110	160	14	14	285	24	50	26,9	8	44
80-50-200	50	125	18	4	80	160	18	8	100	385	160	200	135	153	132	50	100	70	265	212	110	160	14	14	285	24	50	26,9	8	50
80-50-315	50	125	18	4	80	160	18	8	125	500	225	280	191	202	175	65	125	95	345	280	110	160	14	14	370	32	80	35,3	10	110
100-65-160	65	145	18	4	100	180	18	8	100	500	160	200	-	-	-	65	125	95	280	212	110	160	14	14	370	32	80	35,3	10	50
100-65-250	65	145	18	4	100	180	18	8	125	500	200	250	170	193	153	80	160	120	360	280	110	160	18	14	370	32	80	35,3	10	90
125-80-200	80	160	18	8	125	210	18	8	125	500	180	250	154	186	150	65	125	95	345	280	110	160	14	14	370	32	80	35,3	10	92
125-80-315	80	160	18	8	125	210	18	8	125	530	250	315	200	221	191	80	160	120	400	315	110	160	18	14	370	42	110	45,1	12	125
125-100-250	100	180	18	8	125	210	18	8	140	530	225	280	196	228	-	80	160	120	400	315	110	160	18	14	370	42	110	45,1	12	142
150-125-315	125	210	18	8	150	240	22	8	140	530	280	355	225	265	215	100	200	150	500	400	110	160	23	14	370	42	110	45,1	12	164
125-100-315	100	180	18	8	125	210	18	8	140	530	250	315	226	250	-	80	160	120	400	315	110	160	18	14	370	42	110	45,1	12	-
200-150-250	150	240	22	8	200	295	22	12	160	530	280	375	-	-	-	100	200	150	500	400	110	160	23	14	370	42	110	45,1	12	190
200-150-500	150	240	22	8	200	295	22	12	180	670	400	525	-	-	-	120	240	185	720	600	140	200	27	18	500	48	110	51,8	14	485
250-200-315	200	295	22	12	250	355	27	12	200	670	355	450	-	-	-	100	200	150	550	450	140	200	23	18	500	48	110	51,8	14	380
250-200-400	200	295	22	12	250	355	27	12	180	670	355	500	-	-	-	100	200	150	550	450	140	200	23	18	500	48	110	51,8	14	420

Dimensions in mm (subject to change)

Our others models with normalized volute casing

- HMI close coupled pumps with mechanical seal - **documentation FP 05.02 GB**
- NI-M with magnetic drive - NFE 44121- DIN 24256
 ISO 2858 and 5199 - **documentation FP 06.01 GB**
- HMI-M with magnetic drive - **documentation FP 06.02 GB**



FP 05.01 EN