

# PNEUMATIC PUMPS FOR OIL AND ANTIFREEZE

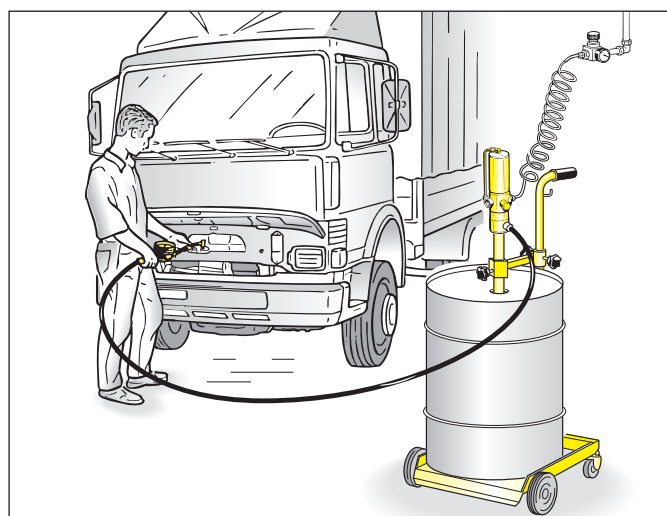

**Ratio 3:1**  
**Capacity 14 l/min**



art. **OE35160**



**OE35173**



**OE35194**

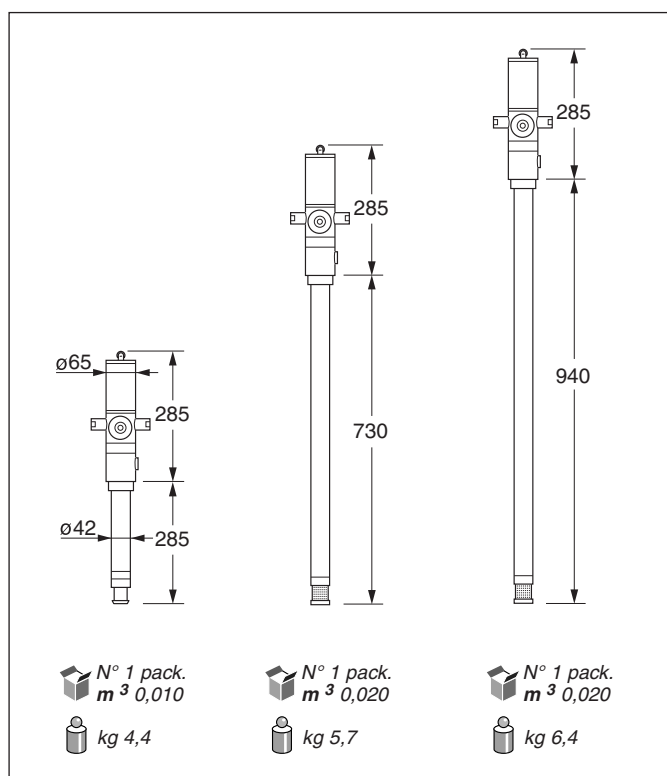

ARTICLE	OE35160	OE35173	OE35194
Suitable for	oil, lubricant and similar products	oil, lubricant and similar products	oil, lubricant and similar products
Gaskets	polyurethane/PU and NBR	polyurethane/PU and NBR	polyurethane/PU and NBR
Suction tube upper body	aluminium	aluminium	aluminium
Suction tube	carbon steel	carbon steel	carbon steel
Inlet air connection	F 1/4" G	F 1/4" G	F 1/4" G
Outlet fluid connection	F 1/2" G	F 1/2" G	F 1/2" G
Suitable for drums of	modular / wall mounted	kg 50/60	kg 180/220
Suction tube diameter	wall mounted	$\phi$ 42	$\phi$ 42
Air consumption (8 bar)	230 l/min	230 l/min	230 l/min
Noise level	80 dB	80 dB	80 dB
Max air pressure	8 bar	8 bar	8 bar
Max viscosity oil delivered	130 SAE	130 SAE	130 SAE