



FACTS

- Outer diameter: 85 mm
- Interchangeable brushblock
- Inspection window

APPLICATION EXAMPLES

- Beverage Filling System • Food Processing • Packaging Machine

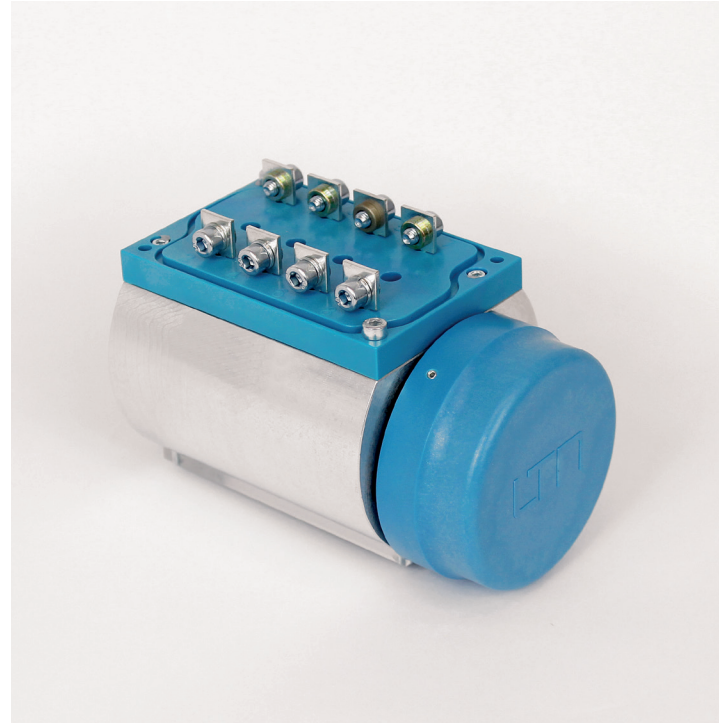

DATA

Number of rings: 4 / 6 / 8 / 10
 Current per ring: max. 25 A
 Voltage: max. 250 V_{AC}
 Dielectric strength: 1250 V_{AC}
 Insulation resistance: > 500 MΩ at 500 V_{DC}

Rotation speed: max. 1500 rpm
 Protection class: IP00 (IP50 with protection caps)
 Operating temperature: -20 °C ... +80 °C
 Electrical connection: screw terminal M5
 Hollow shaft: Ø 25 G7 throughbore
 Housing material: Aluminium & Fibre-reinforced polycarbonate

DESIGN EXAMPLE

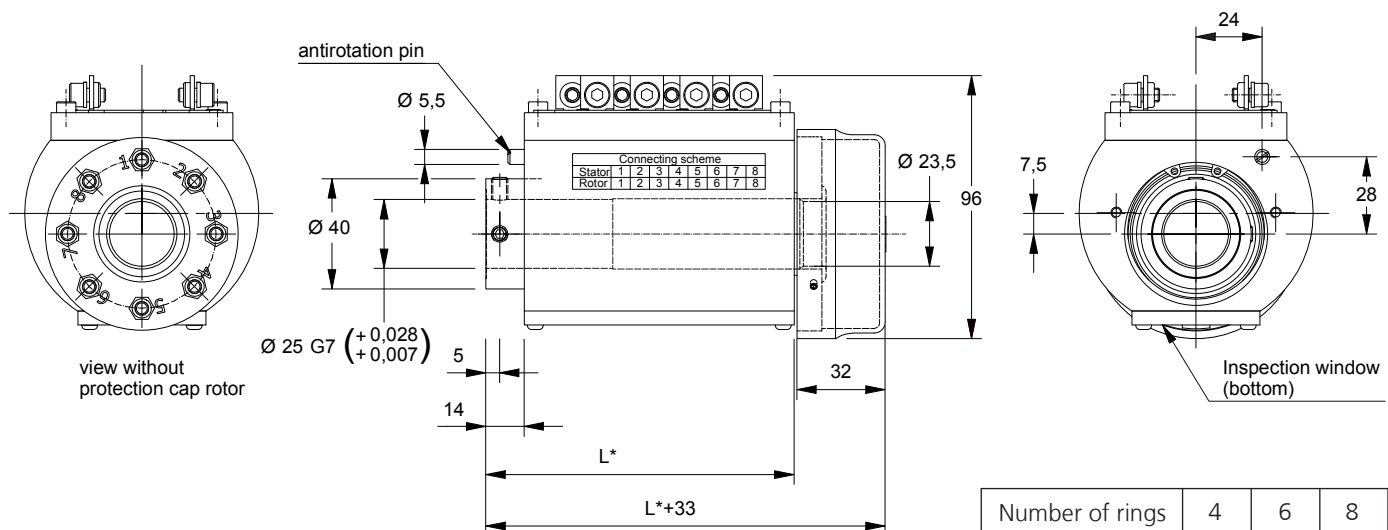

ORDER INFORMATION

- Number of rings: 4 / 6 / 8 / 10
- Operating current
- Operating voltage
- Options: must be ordered separately and will be enclosed with the delivery

OPTIONS

- Positioning-Disc
- Dust box
- Stator protection cap (with cable gland or connector on request)
- All options must be ordered separately and will be enclosed with the delivery

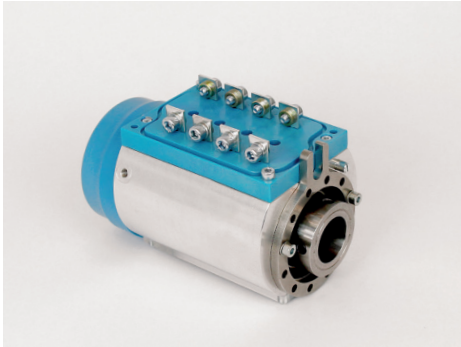

Positioning-Disc (mountable instead of the pin)

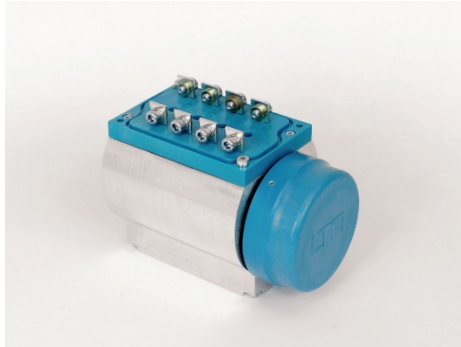

Dust box (mountable instead of the inspection window)

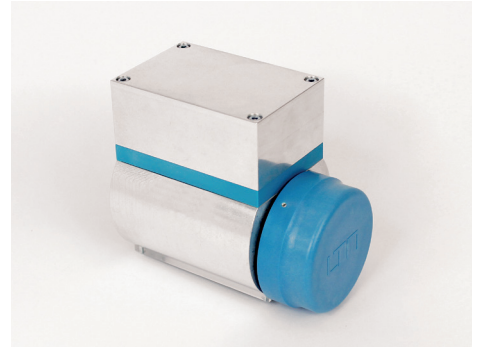

Stator protection cap

