

INDEX

Board description:

Technical characteristics - Dimensions	page. 3
Operating principal	page. 4
Led, trimmer, dip-switch positions.....	page. 4
Connection diagrams	page. 5
Led signal description	page. 6
Trimmer description	page. 6
Dip-switch description	page. 6
Command and power connectors description	page. 7

380S board setting and command instructions:

Board presetting for the number of motor poles	page. 8
Maximum speed setting - zero revolutions offset	page. 8
Acceleration and deceleration ramp regulation	page. 8
DC signal or potentiometer speed regulation	page. 9
Rowan high speed motor couple regulation	page. 10
Command inputs description	page. 11-12
Output description	page. 13

Rowan S series motor connection instructions:

Motor power connector connection	page. 14
Electrical characteristics table of the motors applicable to the 380S board	page. 14
Motor service connector connection	page. 15
Brake connection; table of the power consumption of the 24VDC brake	page. 15

Installation instructions:

Mechanical installation	page. 16
Electrical protection	page. 16
Wiring and electromagnetic compatibility	page. 16
Start up	page. 17-18
Troubleshooting	page. 18
Default settings and standard settings	page. 18

Applicable diagrams:

Forward/backward movement with pre-stop slowing for precise stopping with the brake command ..	page. 19
--	----------

How to substitute the previous (out of production) boards:

Substitution of Cod. 280S.B/0 and 280R with Cod. 380S	page. 5
---	---------

Block diagrams	page. 20
-----------------------------	----------

Components layout	page. 21
--------------------------------	----------

Maintenance instructions for the S series Rowan motors (high slip type)	page. 22-23
--	-------------

TRANSLATION OF THE TEXT IN THE DRAWINGS	pag. 24
--	---------

Warning!

- ROWAN ELETTRONICA s.r.l. declines any responsibility for any inaccuracies contained in this manual, due to printing and/or transcription errors. ROWAN ELETTRONICA s.r.l. reserves the right to make any variations that it considers necessary for better functioning of the product, without prior notification.
- Regarding the data and characteristics mentioned in the manual, a maximum tolerance of 10% has been allowed, if not otherwise indicated.
- The product guaranty is considered ex-works and is valid 6 months from the date of leaving ROWAN ELETTRONICA s.r.l.
- The electrical equipment could create dangerous situations for the safety of both personnel and objects; the user is responsible for the installation of the equipment and for the conformity of the installation with the regulations in force.
- The diagrams contained in this manual are mere examples and should be perfected by the customer according to their specific needs.
- **The equipment must be installed only by qualified personnel**, after having read and understood this manual. In case of doubt, the supplier should be contacted.

COD.380S

ROWAN S SERIES ASYNCHRONOUS MOTOR VARIABLE SLIP BIDIRECTIONAL DRIVE

Technical characteristics

- CE product
- Bidirectional driver for high slip Rowan (S series) with a maximum power of 3kW at 380VAC and 1,5kW at 220VAC.
- Standard power supply limits switcheable between 170 / 260VAC and 330 / 500VAC, frequency 50/60 Hz.
- Rowan 2-4-6 pole motor speed control presetting with a tachometrical dynamo type 20VDC/2800 rpm.
- Operating with linear acceleration and deceleration ramps, regulated by trimmer or external potentiometer from 0,1 sec to 20 sec.
- Speed regulation by potentiometer or ± 10 VDC differential signal.
- Maximum current/couple regulation by internal trimmer, 0 / +10VDC signal or external potentiometer 10Kohm; the current/couple regulation needs an external 4VAC/0.2A TA to be connected in order to measure the current consumed by the motor.
- Maximum voltage regulation for ALQUIST type operation in the case of winder motors.
- Selectable PNP/NPN logic inputs and commutable NO/NC for, START, STOP IN RAMP, SLOW SPEED, INHIBIT ROTATION CLOCKWISE/ ANTI-CLOCK WISE.
- differential tachometrical dynamo input.
- Emergency contact output to signal overload, input line and motor phase loss, Emergency signal delayable from 1 sec to 15sec.
- Contact output for zero command relay.
- Led signals of the logic input states, power supply (power on), emergency relay, zero relay and sense of rotation CLOCKWISE/ ANTI-CLOCK WISE.
- Trimmer regulation of the stability, the acceleration deceleration ramps, maximum and minimum revolutions, maximum couple and slow speed.
- Protection of the logic and pilot circuits by 0.5A fuse.
- Command and power connectors.
- Temperature limit air environment: $+5^{\circ}\text{C} \div +40^{\circ}\text{C}$.
- Storage temperatures: $-25^{\circ}\text{C} \div +70^{\circ}\text{C}$.
- Relative humidity 5 \div 95%.
- Single version in aluminium container IP20, printed with useful designs for operating control and the setting; base dimensions and template fixings interchangeable with mono-directional driver 390S.
- Interchangeable with the previous board series 280R e 280S.B/0.

Conforms to regulations: CEI EN 60204-1 EN 50081-2 EN 50082-2 EN 61800-3

WARNING: Conformity to these regulations is subject to the connection of filtering devices supplied separately and to the careful observance, by the installer, of the instructions on page 16.

OVERALL DIMENSIONS (in mm)

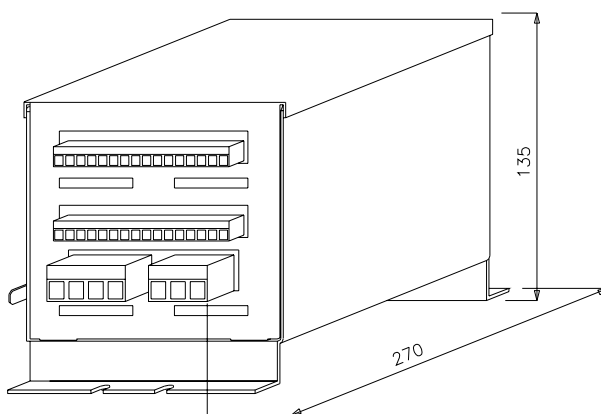
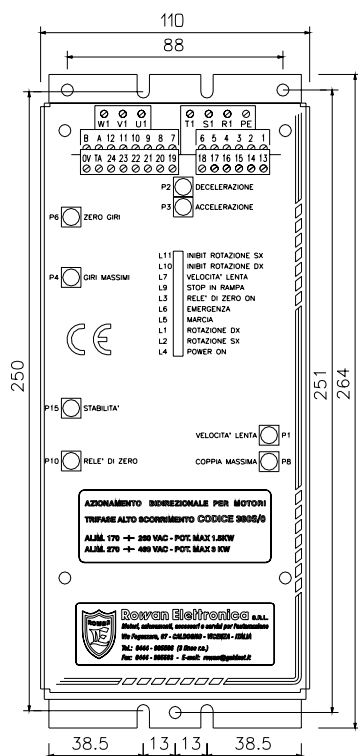

TABLE of MAXIMUM POWER and RECOMMENDED FUSES

CODE	MAX POWER 220 V (240V)LINE		MAX POWER 380V (415-440- 460V)LINE		RAPID GL TYPE RECOMMENDED FUSES	WEIGHT
	HP	kW	HP	kW		
380S	2	1,5	4	3	20	2,1

WORKING PRINCIPLE

The 380S drive was designed to control the speed of **Rowan high slip (S series)** motors, which are equipped with a tachometrical dynamo; it is a three phase voltage regulator with tachometrical feedback, which uses controlled diodes (SCR) piloted by a phase chocking system. The voltage that pilots the motor is the result of an analogic process, that maintains constant revolutions by means of differential control of the actual motor speed, obtained from the tachometrical generator, and that set by a potentiometer or by an external analogic signal.

Combined with a Rowan high slip three phase motor it creates a **extremely quiet and uniform** system with constant speed and coupling, from zero until maximum motor revolutions. The choice of controlled diodes for the power section (moreover already over dimensioned) guarantees reliability in case of extra voltage or extra current. The 380S driver is bidirectional, the motor speed and sense of rotation are set respectively to the value and the polarity of the reference signal with a maximum range of $\pm 10\text{VDC}$.

The operation is extended to all of the 4 quadrants; the combined motor is able to generate a motion couple and braking couple in both senses of rotation with a peak capacity of up to 3 times the nominal couple. The ROWAN 380S+ high speed motor system is particularly indicated therefore for fast movements (e.g.: axle control) also with large inertial loads, not needing any external device such as the braking resistance used for frequency control of normal asynchronous motors or for DC motor drivers.

LED, TRIMMER, DIP-SWITCH POSITIONS

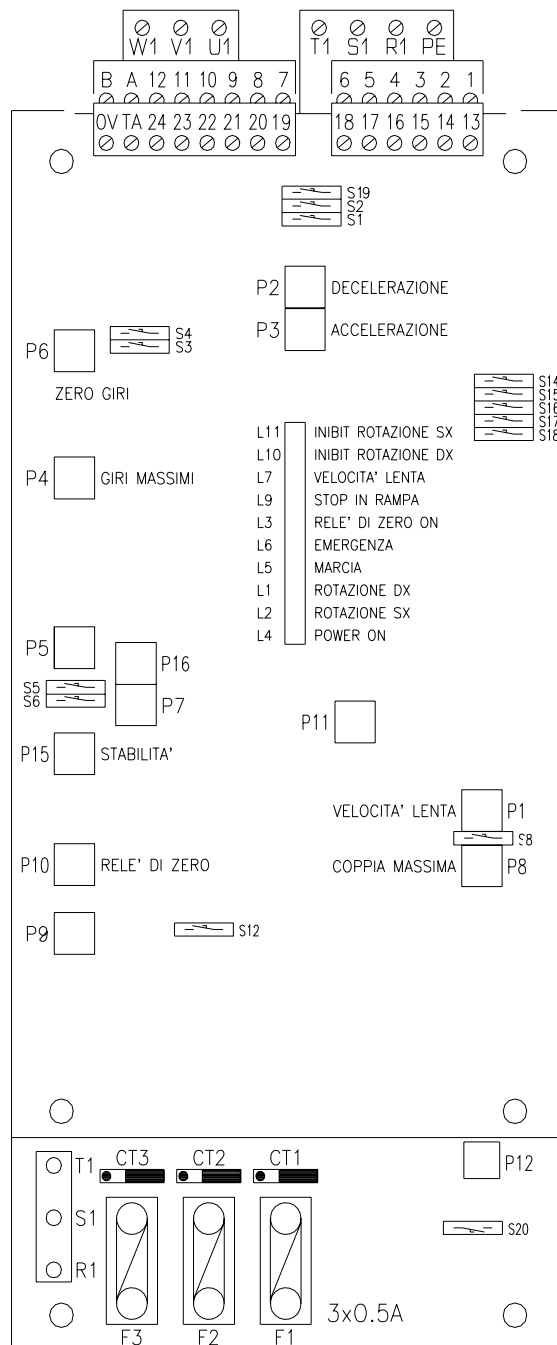

CONNECTION DIAGRAMS
Operating with board in standard preset as described on page. 18

GENERAL CONNECTION DIAGRAM

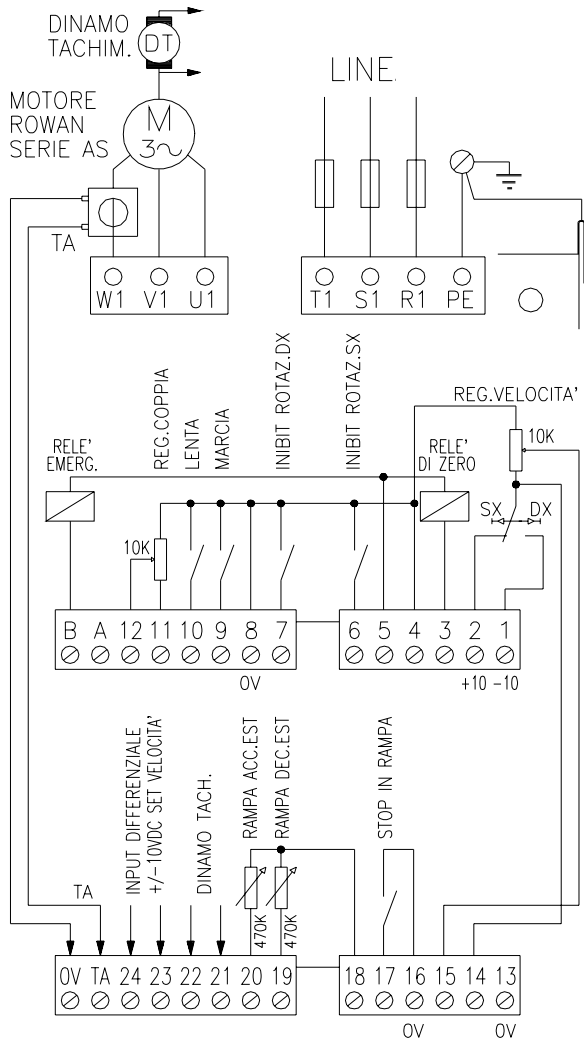

BASE CONNECTION DIAGRAM

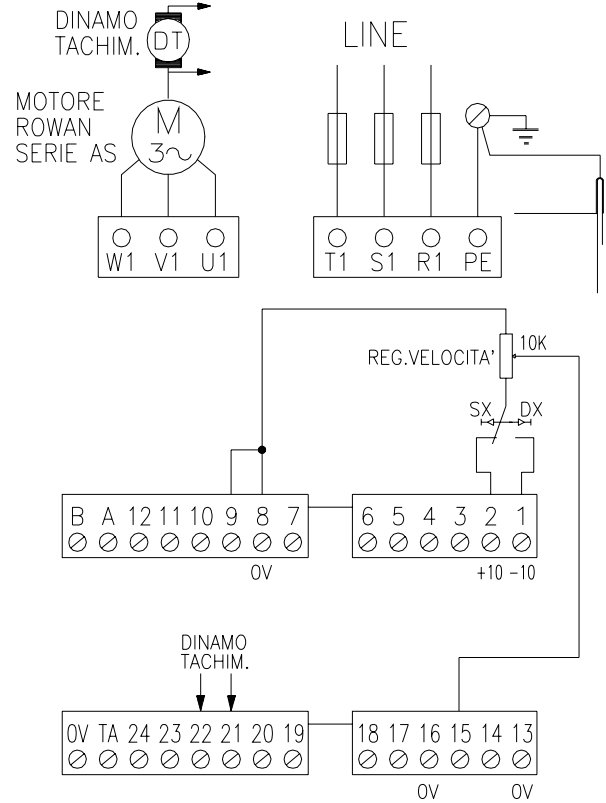

INSTRUCTIONS FOR THE SUBSTITUTION OF Cod. 280S.B/0 and 280R WITH BOARD 380S

- The 380S board is perfectly compatible with the previous series 280/0 and 280R; for the power connector connection simply respect the **same connector initials R1 S1 T1 for the line and U1 V1 W1 for the motor**; for the command connector connection, it is sufficient to insert this into the corresponding connector on the 380S as connector numbers 1 to 22 have the same functions; the last necessary operation is the **standard preset positioning of the dip-switches: S1-S2-S5-S6-S14-S15-S16-S17-S19 CLOSED S3-S4-S8-S12-S18-S20 OPEN - S0 in the NPN position**; in this way the **380S board is standardly preset in the same way as the 280S.B/0 or 280R**.
- If the board to be substituted is set differently from factory standard, bear in mind that the **dip-switches** and the **trimmer with the same initials** on the 380S have kept the **same functions** and therefore it is sufficient to set them in the same way as the 280S.B/0 and 280R.

LED SIGNALS DESCRIPTION

- L1 CLOCKWISE rotation** (Motor rotating field rotation sense):
On with reference to negative speed indicates that the motor is rotating CLOCKWISE .
On with reference to positive speed indicates that the motor, in ANTICLOCKWISE rotation is developing braking couple.
- L2 ANTICLOCKWISE rotation** (Motor rotating field rotation sense):
On with reference to positive speed indicates that the motor is rotating ANTICLOCKWISE.
On with reference to negative speed indicates that the motor, in CLOCKWISE rotation is developing braking couple.
- L3 Zero relay on:** On indicates that the zero relay connected to connectors 3-5 has excited.
- L4 Power on:** On indicates that the board and piloting circuit power supply are present.
- L5 Start:** On indicates the presence of an active command at connector 9, therefore when motor rotation is off, indicates that motor rotation is not enabled.
- L6 Emergency:** On indicates a problem caused by overload, loss of line phase, loss of motor phase; in this case motor start enable is disabled and the externally connected emergency relay is activated; this situation is automatic and can only be unblocked by disconnecting the board power supply; if led L6 comes on consult paragraph "TROUBLESHOOTING" on page. 18.
- L7 Slow insertion:**
On indicates an active slow rotation enable command present at connector 10. In this case the motor passes from the set potentiometer or external signal speed $\pm 10VDC$ to an independent speed, presettable by trimmer P1; the speed change occurs by means of ramps set by trimmers P2 - P3. The slow rotation sense is determined by the reference voltage polarity present at connector 14 and can be taken at connectors 1 or 2.
- L9 Stop in ramp:** On indicates the presence of an active command at connector 17; in this case the motor decelerates with the set deceleration ramp until at zero revolutions; L9 must be off for restart to be allowed.
- L10 Clockwise rotation Inhibited :** On indicates the presence of an active command at connector 7 inhibiting the motor to rotate in the clockwise motor rotating field.
- L11 Anticlockwise rotation Inhibited:** On indicates the presence of an active command at connector 6 inhibiting the motor to rotate in the anticlockwise motor rotating field.

TRIMMERS DESCRIPTION

TRIMMERS ACCESSIBLE WITHOUT REMOVING THE LID

- P1** Slow speed regulation (see page 12).
P2-P3 Acceleration/deceleration ramp regulation (see page 8).
P4 Maximum revolution regulation (see page 8).
P6 Zero revolution Off-Set regulation (see page 8).
P8 Maximum couple limitation regulation (see page 10).
P10 Zero relay SET-POINT regulation (see page 13).
P15 Stability regulation (see TROUBLESHOOTING page18).

TRIMMERS ACCESSIBLE REMOVING THE LID (authorised personnel only)

- P5** 4 pole motor preset - 1400g/m (see page 8)
P9 Minimum couple limitation regulation (see page 10).
P11 Emergency intervention delay regulation (standard setting 7s - minimum 1s - maximum 15s all clockwise).
P12 Zero revolutions hysteresis zone regulation (clockwise increases zero rotation precision).
P7-P16 Stability regulation (see TROUBLESHOOTING page 18).

DIP-SWITCH DESCRIPTION

- S0** logic input settings NPN/PNP.
S1-S2 In/out regulation ramps switching (see page 8).
S3 Ramp time switching (see page 8).
S4 Ramp at S (see page 19).
S5 Motor polarity adaptation (see page 8).
S6 Reply/stability regulation (see page 18).
S8-S12 Couple control setting (see page 10).
S14-S15-S16-S17-S18 Logic command input contact NO/NC settings.
S19 Speed set by potentiometer or $\pm 10VDC$ differential signal selection (see page 9).
S20 Power supply frequency selection 50Hz / 60Hz (see page 17).

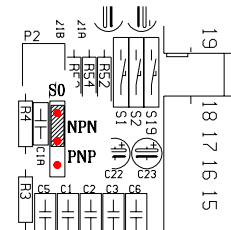

POWER CONNECTOR DESCRIPTION

R1 - S1 - T1 Standard three phase power supply switchable in ranges 170÷260VAC and 330÷500VAC. Make sure to set the voltage change correctly before powering the board. Power supply frequency 50Hz (dip-switch S20 open) or 60Hz (dip-switch S20 closed). See instructions on page. 17

PE 

EMI filter ground connection; connect to the general protection conductor the line inductance coupling for the reduction of conducted emissions (see instructions on page. 16).

WARNING ! The anti EMI filter works with a small ground dispersion current that could make too sensitive differentials intervene at the moment of power up . It is recommended that impulsive current differentials are used.

U1 - V1 - W1 Regulated motor voltage output. Preset the star or triangle motor accordingly to their plate data and power supply requirements. (see page 17).

COMMAND CONNECTOR DESCRIPTION

Reference voltages:

- 1 **-10VDC** reference power supply for external potentiometers (maximum load 5mA).
- 2 **+10VDC** reference power supply for external potentiometers (maximum load 5mA).
- 5 24VDC 50mA external **emergency relay** and **zero relay** coil power supply.
- 8 **0VDC** negative common reference.
- 11 **+10VDC** couple regulation potentiometer power supply reference.
- 13 **0VDC** negative common reference.
- 16 **0VDC** negative common reference.
- 0V **0VDC** TA connection reference.

Analogue voltage inputs:

- 14 Analogue voltage inputs for slow speed motor direction sense selection .
- 15 ± 10 VDC speed reference analogue voltage input.
- TA TA reference input with range 4VAC / 0.2A.

Differential voltage inputs:

- 21 - 22 **Tachometrical dynamo** 20VDC / 2800gm differentie
- 23 - 24 **Speed reference** ± 10 VDC differential voltage input, (input activated with dip-switch S19 open).

Logic inputs:

- 6 Logic input with the function **ANTICLOCKWISE ROTATION inhibit**.
- 7 Logic input with the function **CLOCKWISE ROTATION inhibit**.
- 9 **START** command logic input.
- 10 **SLOW SPEED** command logic input.
- 17 **STOP IN RAMP** command logic input

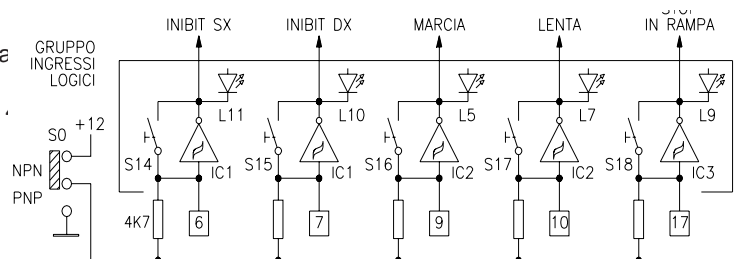

External relay contacts outputs:

- 3 Zero relay COMMON contact.
- A Zero relay NC contact.
NO contact connected internally to ground.

Contatto relè di zero

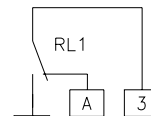

- 4 Emergency relay COMMON contact.
- B Emergency relay NC contact.
NO contact connected internally to ground.

Contatto relè di emergenza

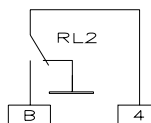

External potentiometer ACC./DEC. ramps regulation connectors:

- 18 External potentiometer acceleration/deceleration regulation ramps common connector.
- 19 ACCELERATION RAMP (470 kohm) external potentiometer connection connector.
- 20 DECELERATION RAMP (470 kohm) external potentiometer connection connector.

PRESET OF THE BOARD FOR THE NUMBER OF MOTOR POLES

- If the motor is 4 or 6 pole close dip-switch S5.
- If the motor is 2 pole open dip-switch S5.
- If the motor is double polarity (2 pole / 4 pole) open S5.

INTERNAL SETTING OF THE MAXIMUM SPEED

This setting is already carried out during the testing stage for 2 and 4 pole motors and is only adjusted by the installed in the case of 6 pole motors, double pole motors or if the board has been **off set**. In such cases proceed as follows:

- Apply a +10VDC or -10VDC signal to connector 15.
- If the motor is 2 pole (S5 open) regulate **P4** for a maximum speed of **2800 rpm** (20 VDC tachometrical dynamo).
- If the motor is 4 pole (S5 closed) regulate **P5** for a maximum speed of **1400 rpm** (10 VDC tachometrical dynamo).
- If the motor is 6 pole (S5 closed) regulate **P5** for a maximum speed of **800 rpm** (5,7 VDC 10 VDC tachometrical dynamo).
- If the motor is a double polarity (S5 open) regulate **P4** for a maximum 2 pole speed of 2600 rpm. (18,5 VDC tachometrical dynamo); for this application; it is necessary to connect in series with positive speed regulation potentiometer (10K ohm) connector a 10K ohm 0,5W resistor. This resistor is short circuited when the motor is commuted to 2 pole mode.
- P4 - P5 regulated in a clockwise sense increases speed.

Warning! Do not exceed with the regulation the indicated maximum speeds as this would send the motor in over load (even when unloaded) and in any case would cause time response delays.

ZERO REVOLUTION OFFSET SETTING

- Give zero volts to connector 15 or close stop in ramp.
- Regulate **P6** until the motor stops.

ACCELERATION/DECELERATION RAMP REGULATION

Internal ramp regulation

- Close dip-switches S1 - S2.
- P2 regulates the deceleration ramp (clockwise regulation increases ramp time).
- P3 regulates the acceleration ramp (clockwise regulation increases ramp time).
- S3 open fixes the ramp regulation field from minimum 0,1sec to maximum 1,5 sec.
- S3 closed fixes the ramp regulation field from minimum 1,5 sec to maximum 20 sec.

External acceleration ramp regulation

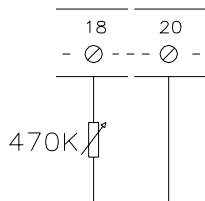

- **The connection must be made with screened cable** and as close as possible to the driver.
- open dip-switch S2;
- trimmer P3 is in series with the external potentiometer.
- with S3 open and P3 at maximum external ramp regulation from 1,5sec (0kW) to 3sec (470kW).
- with S3 closed and P3 at maximum external ramp regulation from 20sec (0kW) to 40 sec (470kW).
- with P3 at minimum external acceleration ramp regulation field as internal regulation ramps.

External deceleration ramp regulation

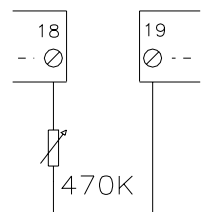

- **The connection must be made with screened cable** and as close as possible to the driver.
- open dip-switch S1.
- trimmer P2 is in series with the external potentiometer.
- with S3 open and P2 at maximum external ramp regulation from 1,5sec (0kW) to 3sec (470kW).
- with S3 closed and P2 at maximum external ramp regulation from 20sec (0kW) to 40 sec (470kW).
- with P2 at minimum external acceleration ramp regulation field as internal regulation ramps.

EXTERNAL POTENTIOMETER SPEED REGULATION

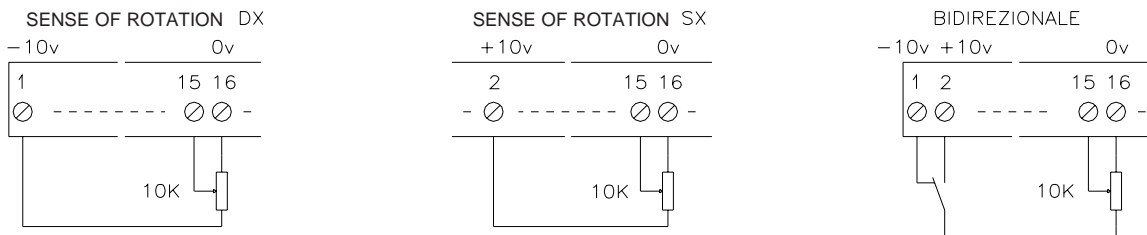

- To activate this type of regulation dip-switch S19 must be closed.
- The load at connectors 1-2 must not exceed 5mA (potentiometer resistance minimum 5k Ω / maximum 100k Ω).
- Optimum potentiometer value 10k Ω (min 3k Ω - max 100k Ω).
- **Connection must be made with screened cable.**

EXTERNAL $\pm 10VDC$ SIGNAL SPEED REGULATION

(input activated with dip-switch S19 open)

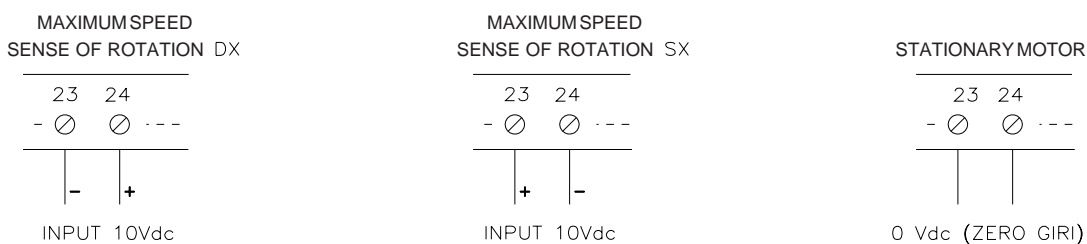

- To activate this type of regulation dip-switch S19 must be open.
- Differential input pilotable by interface board, positioning instruments, PLC or computer with guaranteed galvanic isolation from the high tension and immune from common interference.
- **Connection must be made with screened cable.**

ROWAN MOTOR COUPLE REGULATION WITH AMPEROMETRICAL FEEDBACK

An example of the use of this function; is when a Rowan motor drives tangentially to wind or unwind a bobbin with a controllable pull.

The maximum speed is set by the **revolution regulation potentiometer**, and the maximum pull by the **couple regulation potentiometer**, which limits the controlled motor current using a closed loop with an amperometric transformer (TA); the maximum couple regulation potentiometer field may be set by trimmer P8 MAXIMUM COUPLE and by the use of the TA (current plug connected and a number of wire passes) which must be connected to connectors TA-0V.

The board is designed to operate with an amperometric transformer type 151/110 with a range of 4VAC.2A supplied by Rowan Elettronica. Characteristics TA 151/110 with ONE WIRE PASSING:

Plug 1 - 2 = maximum output 25A
 Plug 1 - 3 = maximum output 50A
 Plug 1 - 4 = maximum output 100A

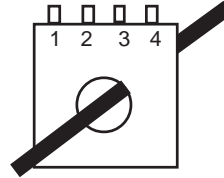

The maximum load of the various plugs may be divided by the number of wire passes; for example, if plug 1 - 2 is used and 5 wire passes are made through the TA, the maximum output will be a current of 5A; choose the TA plug and the wire passes accordingly to the Rowan motor used.

This function may be used together with external apparatus such as PLC or with the Rowan Cod. 274 servodiametric instrument (in the case of winder/unwinder with controllable pull and bobbin axle motor); this apparatus may supply, by means of a 0/+10VDC signal, the maximum speed signal (connectors 23-24) and that of maximum couple (12 - 13), instead of manual potential regulation.

COUPLE REGULATION using internal trimmer:

- to insert the internal limitation regulation close S8-S12;
- P8 regulates maximum motor current;
- P9 regulates minimum current (set to zero as standard);
- P8-P9 in a clockwise direction increases the current.

COUPLE REGULATION using external trimmer or D.C. signal:

- to insert the external limitation regulation close S12 and open S8.
- the optimum potentiometer value is 10Kohm (minimum 3 Kohm - maximum 100 Kohm).
- Input 12 has a 50 Kohm load resistance and is pilotable by interface board, PLC and computer with guaranteed high tension isolation. The external potentiometer or DC signal regulation field is set by trimmer P8 (maximum) e P9 (minimum).
- the connection must be made with screened cable;

EXTERNAL REGULATION by POTENTIOMETER

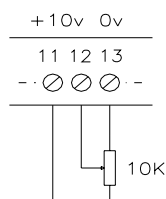

EXTERNAL REGULATION by DC SIGNAL

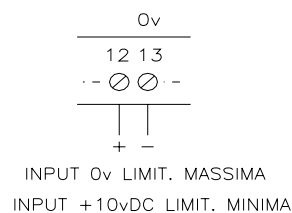

ALQUIST SYSTEM COUPLE REGULATION

This type of regulation is used for example, for pull control of the material to be wound by the motor applied to the bobbin axle, whose minimum and maximum diameter variation does not exceed the ratio of 1/3; in this case the couple is regulated limiting motor voltage and not the current, therefore the TA connection is omitted.

The regulation possibilities are the same as described for amperometric feedback bearing in mind that the maximum must be decreased considerably by trimmer P8 (regulating clockwise) to re-enter in the current regulation field.

WARNING: bear in mind that, **when regulating couple**, in blocked rotor operation, Rowan motor maximum current in continuous operation must be at least 20% less than the nominal current.

COMMAND INPUTS DESCRIPTION

START COMMAND

- **The activation** of the start command is signalled by led L5.
- When the **start is activated**, it enables motor rotation in acceleration ramp until the set speed.
- When the **start is disabled**, it statically removes motor voltage (if the motor is rotating it will not brake) zeroes the ramps and excludes the other commands.

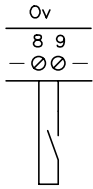

If the start is commanded by a pure contact (see the diagram at the side):

- Set S0 to the NPN position and close dip-switch S16.
- To activate the start close the contact.
- To disable the start open the contact.

If the start is commanded by NPN/PNP transistor logic (see diagram fig.1 page.13):

- If NPN logic, set S0 to the NPN position and open dip-switch S16.
- If PNP logic, set S0 to the PNP position and open dip-switch S16.
- To activate the start give a positive output (min 8VDC max 24VDC).
- To disable the start give 0VDC.
- The opening / closing of dip-switch S16 causes, in any case, the activation / deactivation and therefore gives the possibility to adapt the input to any type of both NO and NC command.

STOP IN RAMP COMMAND

- **The activation** of the stop in ramp command is signalled by led L9.
- When the **stop in ramp is activated**, it causes motor to decelerate from the set speed until zero revolutions, with the ramp set by P2.
- When the **stop in ramp is deactivated**, enables motor rotation until the set speed, with the ramp set by trimmer P3.

If the stop in ramp is commanded by a pure contact (see the diagram at the side):

- Set S0 to the NPN position and open dip-switch S18.
- To activate the stop in ramp close the contact.
- To disable the stop in ramp open the contact.

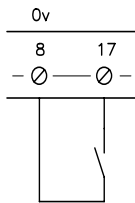

If the stop in ramp is commanded by NPN/PNP transistor logic (see diagram fig.1 page.13):

- If NPN logic, set S0 to the NPN position and close dip-switch S18.
- If PNP logic, set S0 to the PNP position and close dip-switch S18.
- To activate the stop in ramp give a positive output (min 8VDC max 24VDC).
- To disable the stop in ramp give 0VDC.
- The opening / closing of dip-switch S18 causes, in any case, the activation / deactivation and therefore gives the possibility to adapt the input to any type of both NO and NC command.

INHIBIT ANTICLOCKWISE ROTATION COMMAND

- **The activation** of the **inhibit anticlockwise rotation** command is signalled by led L11.
- The **inhibit anticlockwise rotation** command excludes clockwise rotation braking and anticlockwise start.
- The **disabled inhibit anticlockwise rotation** command restores bidirectional operation.

If the inhibit anticlockwise rotation is commanded by a pure contact (see the diagram at the side):

- Set S0 to the NPN position and close dip-switch S14.
- To activate the **inhibit anticlockwise rotation** close the contact.
- To disable the **inhibit anticlockwise rotation** open the contact.

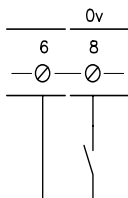

If the inhibit anticlockwise rotation is commanded by NPN/PNP transistor logic (see diagram fig.1 page.13):

- If NPN logic, set S0 to the NPN position and open dip-switch S14.
- If PNP logic, set S0 to the PNP position and open dip-switch S14.
- To activate the **inhibit anticlockwise rotation** give a positive output (min 8VDC max 24VDC).
- To disable the **inhibit anticlockwise rotation** give 0VDC.
- The opening / closing of dip-switch S14 causes, in any case, the activation / deactivation and therefore gives the possibility to adapt the input to any type of both NO and NC command.

INHIBIT CLOCKWISE ROTATION COMMAND

- The **activation** of the **inhibit clockwise rotation** command is signalled by led L11.
- The **inhibit clockwise rotation** command excludes anticlockwise rotation braking and clockwise start.
- The **disabled inhibit clockwise rotation** command restores bidirectional operation.

If the inhibit clockwise rotation is commanded by a pure contact (see the diagram at the side):

- Set S0 to the NPN position and close dip-switch S15.
- To activate the **inhibit clockwise rotation** close the contact.
- To disable the **inhibit clockwise rotation** open the contact.

If the inhibit clockwise rotation is commanded by NPN/PNP transistor logic (see diagram fig.1 page.13):

- If NPN logic, set S0 to the NPN position and open dip-switch S15.
- If PNP logic, set S0 to the PNP position and open dip-switch S15.
- To activate the **inhibit clockwise rotation** give a positive output (min 8VDC max 24VDC).
- To disable the **inhibit clockwise rotation** give 0VDC.
- The opening / closing of dip-switch S14 causes, in any case, the activation / deactivation and therefore gives the possibility to adapt the input to any type of both NO and NC command.

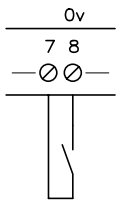

SLOW SPEED COMMAND

- The **activation** of the **slow speed** command is signalled by led L7.
- When the **slow speed** command is **activated**, it excludes speed setting at connector 15 or connectors 23-24 and selects speed setting by means of the internal trimmer P1; the sense of rotation is determined by the voltage polarity applied to connector 14 and the speed is settable from zero to 70% of maximum motor speed; the passing from set speed to slow speed and vice versa is subject to the acceleration / deceleration ramps set by P3/P2.
- The **disabled slow speed** command restores speed setting by external references.

If the slow speed is commanded by a pure contact (see the diagram below):

- Set S0 to the NPN position and close dip-switch S17.
- To activate the **slow speed** close the contact.
- To disable the **slow speed** open the contact.

If the slow speed is commanded by a pure contact (see the diagram below):

If the slow speed is commanded by NPN/PNP transistor logic (see diagram fig.1 page.13):

- If NPN logic, set S0 to the NPN position and open dip-switch S17.
- If PNP logic, set S0 to the PNP position and open dip-switch S17.
- To activate the **slow speed** give a positive output (min 8VDC max 24VDC).
- To disable the **slow speed** give 0VDC.
- The opening / closing of dip-switch S17 causes, in any case, the activation / deactivation and therefore gives the possibility to adapt the input to any type of both NO and NC command.

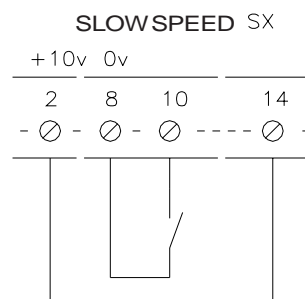
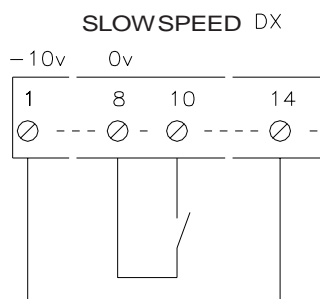

OUTPUT DESCRIPTION

The voltage supplied by the device to the zero external relay is 20VDC and the power line is 380VOLT (or 220VOLT if presetted); for that reason, if the power line goes down over than 15% of the voltages indicated, we can have troubleshooting on the relay mentioned. On that case it is necessary to supply the external relay by an oportune independent source like those on drawings Fig.1.

MOTOR SPEED SENSING OUTPUT

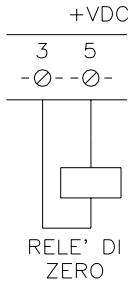

If the output is connected to a relay (zero relay) as shown in the diagram at the side:

- Connect a relay 24 VDC maximum 50mA.
- Each time the motor speed exceeds the speed threshold set by trimmer P10 the lamp L3 lights and the relay closes.
- Trimmer P10 (zero relay set point) sets the relay excitation for a motor speed field of 30 rpm to 1900 rpm.
- The zero relay may be used, for example, for the automatic release of the start relay when the motor is not running.

If the output is connected to NPN/PNP logic inputs (see diagram fig.1):

- If NPN logic, Each time the motor speed exceeds the speed threshold set by trimmer P10 the lamp L3 lights and the PLC input passes from 24VDC to 0VDC.
- If PNP logic, Each time the motor speed exceeds the speed threshold set by trimmer P10 the lamp L3 lights and the PLC input passes from 20VDC to 0VDC.

EMERGENCY OUTPUT

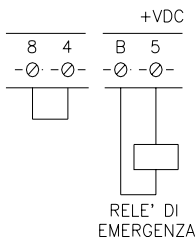

If the output is connected to a relay as shown in the diagram at the side:

- Connect a relay 24 VDC maximum 50mA.
- The relay closes when the board is powered and stays closed during normal operation.
- In an emergency situation, led L6 lights, and the relay opens (see troubleshooting page 18). It is necessary to remove board power supply in order to recover the original situation.

If the output is connected to NPN/PNP logic inputs (see diagram fig.1):

- If NPN logic, in an emergency situation when led L6 lights and the PLC input passes from 0VDC to 24VDC.
- If PNP logic, in an emergency situation when led L6 lights and the PLC input passes from 20VDC to 0VDC.

EXTERNAL INPUT /OUTPUT NPN/PNP (PLC) LOGIC CONNECTION DIAGRAM

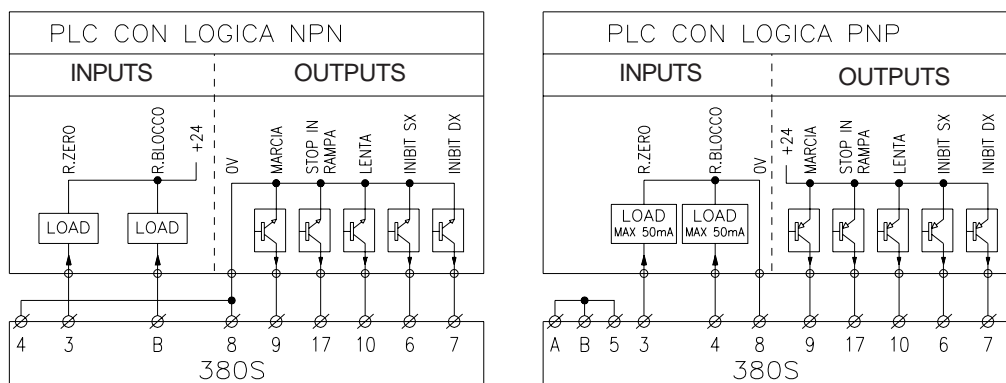
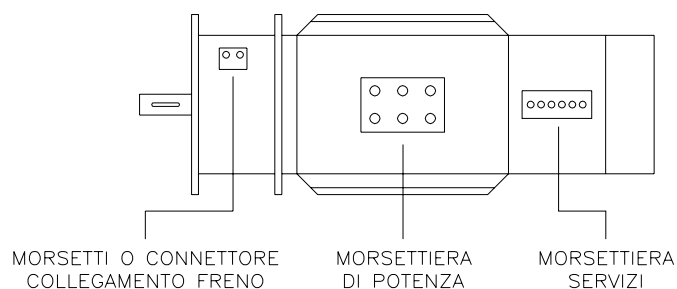

Fig. 1

ROWAN S SERIES MOTORS CONNECTION INSTRUCTIONS

POWER CONNECTOR CONNECTION



The power connector connection, even though passing through the speed control driver, remains as a normal asynchronous three phase motor, therefore, if indicated by the motor plate data:

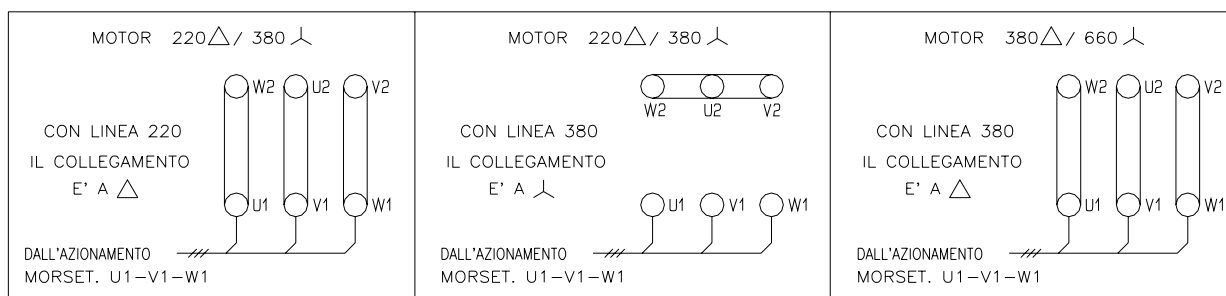

ELECTRICAL CHARACTERISTICS TABLE OF THE MOTORS APPLICABLE TO THE 380S BOARD

MOTOR POWERS		MEC SIZE	MOTOR NOMINAL CURRENT I NOMINAL		FAN POWERS	
			230Vac	400Vac	AXIAL	SCROLL FAN
HP	KW		A	A	VA	VA
0,15	0,11	63	1,6	0,9	16	40
0,25	0,18	71	1,9	1,1	16	40
0,5	0,37	80	3,1	1,8	16	40
1	0,75	90	6	3,5	19	55
2	1,5	100	11	6,5	40	55
3	2,2	112	*	9	40	100
4	3	112L	*	12	40	100

For motor overload / overheating protection the use of the thermic sensor contact located on the motor windings and available at the service connector is quite sufficient. (see page 15). The thermic sensor exists on all motors apart from the MEC 63 which must be protected by a thermic valve set to a current of 15% more than the nominal value.

SERVICE MOTOR CONNECTOR CONNECTION

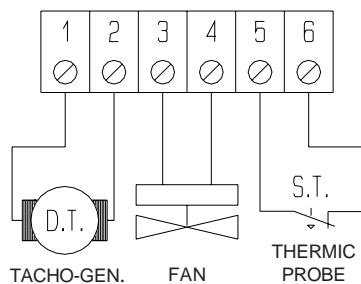

1 - 2 Tachometrical dynamo: it is possible to obtain the voltage from tachometrical dynamo which is fitted to the motor axle from this connector. It supplies a DC voltage, equal to 20VDC at 2800 rpm, directly proportional to the motor speed; for this reason it can, as well as being connected to the driver for motor speed control, be used for analogue rev. counters with display or other servo-mechanisms, provided that the overall load does not exceed 3Kohm (maximum dynamo current 10mA). To avoid interference, it is wise to connect the tachometrical dynamo using screened cable, especially when it is close to the power cable.

3 - 4 Cooling fan: it is necessary to supply this connector with 220VAC for the separate motor cooling; this should be present also when the motor is not running as to make use of such times for motor cooling. In some high power Rowan motors fitted with three phase cooling fans, the power is supplied directly from the motor base to the cooling fan. For cooling fan power consumption consult the table on page 14.

5 - 6 Thermic sensor: It is a normally closed contact which opens when the motor windings exceed 150°C, safety limits corresponding to class H (180°C). It is used as an emergency opening the start relay bearing in mind that the maximum load of the contact is 1A - 230VAC.

Warning! in the ROWAN MEC 63 motor service connector connectors 5 - 6 are not present (the 63 motor has no thermic sensor).

BRAKE CONNECTION

Rowan motors may be supplied, on request, with an electromagnetic brake. This would mean a purposely built motor with a lengthened axle and brake fitted to the front part, supported by a bell shaped cover that reproduces normal flanging.

The brake is a **Spring type:** it is necessary to remove the brake power supply to stop the motor axle. It is used as a safety brake if the power supply should be lost, in the case of over head loads such as bridge cranes, cranes etc. (verify whether it would be necessary to adapt the air gap at 0,3mm ± 0,005).

This brake operates at 24VDC and is powered by a single connector or a connector found on the bell shaped front brake holder. It is always convenient to connect a diode or R/C in parallel to the brake, above all when close to equipments which are particularly subject to interferences.

It is necessary to bear in mind that the flywheel diode has a maximum filtering efficiency, but it delays spring brake insertion.

Note: for a better use of the brake, Rowan Elettronica suggests the following connection to the C321S device:

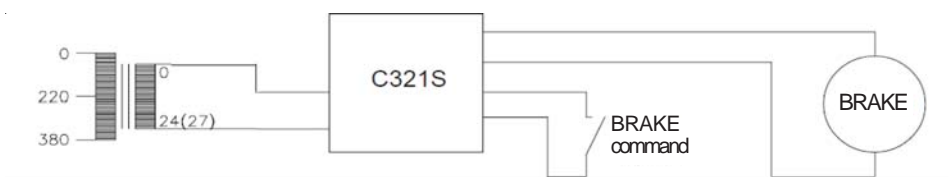

This device gives a 33÷37Vdc starting voltage and a succeeding 21÷23Vdc maintenance voltage. In this way the brake release is sped and the overtemperature, during the continuous service, is avoided.

TABLE OF THE POWER CONSUMPTION OF THE 24VDC BRAKE

BRAKE COUPLE / ABSORPTION CHARACTERISTICS AND IDENTIFICATION CODES						
MOTOR	SPRING BRAKE					
	TORQUE	ABSORPTION	TYPE	UNBLOCKING LEVER	BRAKE STARTING TIME	BRAKE STOPPING TIME
	Nm	W	Cod.	Cod.	ms	ms
63 / 71	4,5	15	FRM63/71K01	/	17	35
80	8	20	FRM80K02	/	35	65
90 / 100	16	30	FRM91011K04	LEVA91011	40	90
112 / 112L	35	45	FRM112K05	LEVA112	50	120

INSTALLATION INSTRUCTIONS

MECHANICAL INSTALLATION

Please note the following warnings while installing the driver:

- Check that the environment in which it is to be installed complies with the environmental characteristics as described on page 3 (temperature - humidity - protection degree).
- Allow maximum air flow for cooling, avoiding driver overlaying and leaving a space of at least 100 mm both above and below the driver and at least 50 mm at the sides.
- Avoid excessive vibrations and collisions.
- Leave enough space for any anti-EMI filters (see the following paragraph).

The cod. 380S series boards work correctly when the temperatures on their cases and inside their housing cabinets are between -5°C e +40°C; temperatures above or below could cause operating anomalies, speed control drifts and, when too high, they could cause breakages; it is therefore advisable to position the board away from heat sources and to ventilate the cabinet if environmental temperatures are high.

ELECTRICAL PROTECTION

The Cod.380S board is provided with a protection device which intervenes when the motor is out of tachometrical control, such as in the case of overload, power-line and motor phase loss, tachometrical loss and tachometrical polarity inversion; The emergency intervention removes motor rotation enable and excites the emergency externally connected relay; the board piloting circuit is also protected by a series of 0,5A fuses located on the lower board which houses the power connectors.

For the power amperometric protection it is necessary to provide external fuses for sort circuit protection of 20A of the type GL FAST (and thermic circuit breaker calculated for a current of 15% above the nominal current for MEC 63 motors only).

The thermic sensor incorporated in the motor may be used as an alternative to the thermic relay.

To select potentiometer or DC signal use relays with current base contacts; absolutely avoid the use of auxiliary relay contacts for this type of operation.

WIRING AND ELECTROMAGNETIC COMPATIBILITY

In order to limit the disturbances induced in the connection cables:

- Avoid passing the command connector connection cables in the same cable run as the power cables.
- Connect potentiometers, tachometrical dynamo, DC signals using screened cable.
- Connect each end of the screen separately to the common ground point of the cabinet.
- Avoid ground loops.
- To avoid conducted emissions on the power line and improve immunity to this type of disturbances, connect the filter inductance

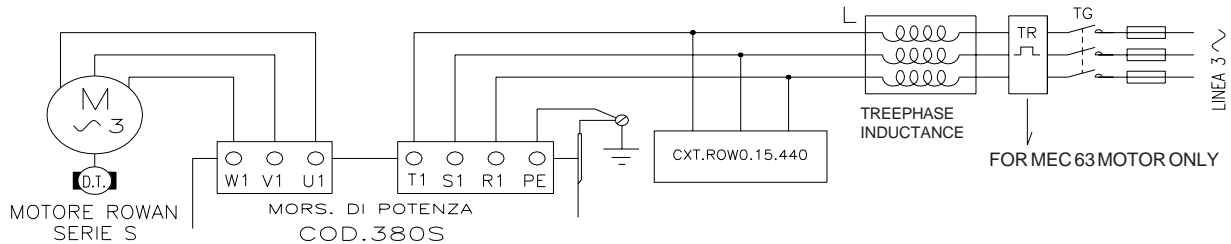

Warning! The anti-EMI works with a small ground dispersion current which may cause too sensitive differentials to intervene at the moment of power-up. The use of differentials is recommended for impulsive current.

Rowan Elettronica may supply the complete ANTI EMI on request: the inductances are chosen accordingly to the nominal current of the applied Rowan motor, or the sum of the motors. A single inductance may serve more than one driver in parallel. The external EMI filter is constituted by an inductance L and by three EMI condensers type Cx; the condensers are supplied in plastic box (dim. 65x35x29mm) along with connectors type Faston named CXT.R0W0.15.440.

See drawing for connection:

If a **rephasing circuit**, is needed, this must be mounted before the ANTI EMI filter, otherwise the emission reduction will not function.

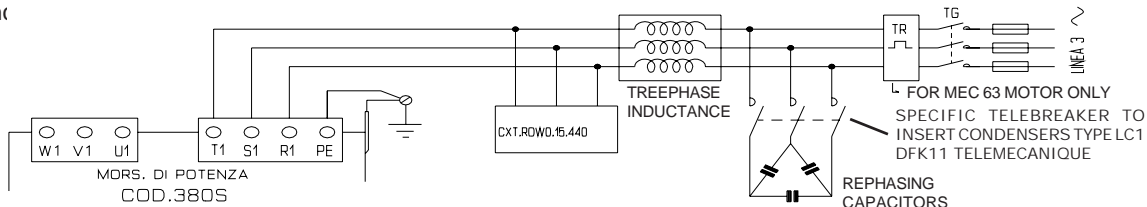

CODE AND CHARACTERISTICS OF THE ANTI EMI FILTER THREE PHASE INDUCTANCES

CODE	MAXIMUM CURRENT (A)	INDUCTANCE (mH)	DIMENSIONS (mm)		
			H	B	L
IMPT.10A.1,5	10	1.5	125	60	120
IMPT.20A.09	20	0.9	150	75	150

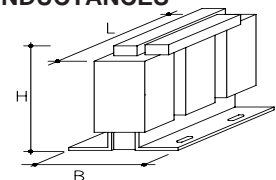

START-UP

PRELIMINARY OPERATIONS:

Prior to fixing the board, set the three voltage changers according to the power supply and the dip-switch **S20** according to the frequency (50Hz/60Hz), bearing in mind that the board leaves Rowan preset for the highest voltage range and for the frequency of 50Hz; in order to access the voltage changers and the dip-switch S20, found on the middle board. It is necessary to remove the plug connectors and remove the printed cover; the voltage changers are set in the following way:

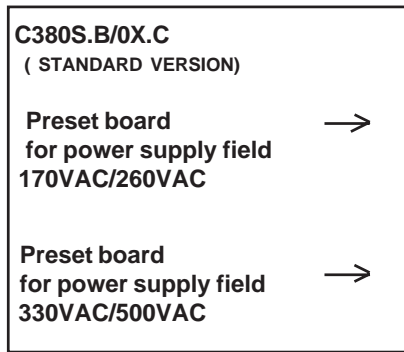
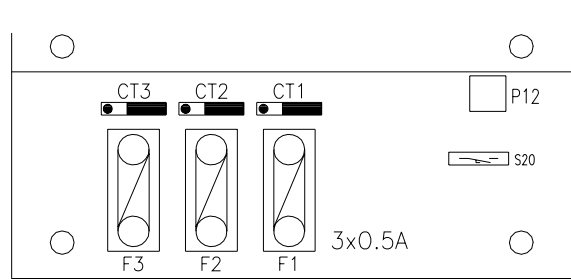

F1 - F2 - F3 0,5 A pilot protection Fuses.

If the power supply frequency is 50Hz, open dip-switch S20.

If the power supply frequency is 60Hz, close dip-switch S20.

The rest of the setting is carried out on the top board where the trimmers, dip-switches and leds are to be found.

To put the board into minimum operation carry out the electrical connections shown in the base diagram on page 5. (potentiometer speed control) and follow the instructions below:

Set dip-switch S5 according to the motor polarity to be regulated:

2 pole motor / dip-switch S5 open

4 - 6 pole motor / dip-switch S5 closed

In the case of 6 pole motors it is necessary to later regulate P5 in a clockwise direction until the tachometrical dynamo generates about 5,7 VDC with the potentiometer or DC signal at maximum.

Choose the acceleration and deceleration ramp range:

Dip-switch S3 open Trimmer P2 regulation field minimum deceleration 0,1 sec - maximum 1,5 sec.

Trimmer P3 regulation field minimum acceleration 0,1 sec - maximum 1,5 sec.

Dip-switch S3 closed Trimmer P2 regulation field minimum deceleration 1,5 sec - maximum 20 sec.

Trimmer P3 regulation field minimum acceleration 1,5 sec - maximum 20 sec.

Connect the start as shown in the base connection diagram on page 5; bearing in mind that the contact must be **closed** for motor rotation enable.

Connect the revolution regulation potentiometer at connectors 2-15-8; with the wiper 15 towards connector 8(0VDC) the motor will be idle; with the wiper 15 towards connector 2 (+10VDC) the motor will rotate at maximum speed.

Set the remaining dip-switches: S1-S2-S6-S14-S15-S16-S17-S19 closed and S4-S8-S12-S18 open.

Carry out the motor board connections according to the following instructions (also see page14-15):

Connect in a star or triangle way, according to the line and motor plate data; connect the motor to earth.

The tachometrical dynamo signal, which is to be connected to the 380S board connectors 21 - 22 , is obtained from the motor service connectors 1 - 2.

The cooling fan power supply (220VAC - 50Hz) must be connected to the motor service connectors 3 - 4; The cooling fan power supply must not be connected together with the start but connected to the command panel; this to give the possibility of cooling the motor even in the moments when not running; for motors with three phase cooling fans the connection is carried out directly to the fan base.

The thermic sensor is connected to the motor service connectors 5 - 6, this has a normally closed contact (1A-230VAC) which should be connected in series with the emergency; it is located directly on the motor windings and **opens** if the motor windings temperature reaches the safety limits for the tropicalized windings in class H (150°C).

TO MAKE THE MOTOR ROTATE:

Regulate the potentiometer in such a way that its wiper connected to connector 15 is in short circuit with connector 8. Power the board, the motor must be idle.

The lamp **L4** on **(power on)** indicates the presence of the piloting board power supply, the lamp **L5** on **start** indicates motor rotation is enabled.

Turning the potentiometer, the motor should follow the regulation increasing or decreasing speed with the set acceleration or deceleration ramps; verify that the motor reaches maximum speed; If necessary adjust the maximum speed by means of trimmer P4 (MAXIMUM REVOLUTIONS). Be careful not to exceed the maximum regulation as this would send the motor in overload even when unloaded; If corresponding to the set maximum speed this phenomenon is noticed, regulate trimmer P4 in an anticlockwise direction until the motor absorption reaches the same value as the absorption measured at an **intermediate speed**. If minimum speed is to be set to a value different from the standard (zero revolutions) it is possible to do this by regulating P6 (MINIMUM REVOLUTIONS). In any case verify the absorption, in continues operation, are balanced for all three phases and do not exceed those of the motor plate data.

Bear in mind that the motor rotation enable is given only after 0,3 sec of board power up; this reset time is necessary to guarantee a correct restart in acceleration ramp every time the board is powered. It is recommended, if it is necessary to have frequent motor stopping and starting, to keep the board always powered and to statically command the motor using the stop in ramp or start commands.

If it is necessary to have **high precision speed control dip-switch S6 may be opened**; in this case the unloaded / loaded speed variation will be minimal and the motor will be able to give nominal couple even at low speeds (1 - 2 rpm), however delaying speed control response times.

TROUBLESHOOTING

- 1) The motor does not respect the set speed at start up, turns at maximum speed, the lamp L3 is off and after about 8 seconds the emergency intervenes and the lamp L6 comes on.
Possible cause: the tachometrical dynamo signal does not arrive at connectors 1 and 2, check the dynamo connections until the motor service connector and if necessary the dynamo itself by removing the fan covers and fans to access it.
- 2) The motor does not respect the set speed at start up, turns at maximum speed, the lamp L3 is off and after about 8 seconds the emergency intervenes and the lamp L6 comes on.
Possible cause: the tachometrical dynamo signal arrives at connectors 21 and 22 but the polarity is wrong; swop over the two signal wires.
- 3) When the motor is started it does not reach maximum speed, it turns at a very low speed or is idle, and after about 8 seconds the emergency intervenes and the lamp L6 comes on.
Possible cause:
 - a) if the motor absorbs in an unbalanced way on all three phases a current of about twice the nominal current it means that there is a mechanical block or a load greater than the power of the motor; check the mechanical transmission.
 - b) if the motor absorbs in an unbalanced way on all three phases check that:
 - connector R1 S1 T1 is not missing a phase.
 - a phase is not missing in the connection between the board connectors U1 V1 W1 and the motor.
 - one of the three 0,5A piloting protection fuses is not interrupted ; to access the fuses located on the middle board it is necessary to remove the connection plugs and the printed cover, (fuses F1 F2 F3 are located close to the voltage changers see page 17).
- 4) The motor turns in an irregular way and keeps drifting.
Possible cause:
 - a) Mechanical transmission with too much play or lose belt ; regulate trimmer P15 (STABILITY) in a clockwise direction until control is stabilised; if this is not sufficient, remove the printed cover and regulate trimmer P7 in a clockwise direction and then regulate trimmer P16 in a clockwise direction.
 - b) tachometrical dynamo worn out after many hours of operation or damaged due to bad motor installation.

DEFAULT SETTINGS AND STANDARD SETTINGS

The cod.380S board leaves Rowan tested with the following settings:

- Trimmer positions as shown come shown on the component lay out diagram page 21.
- Dip-switches S1-S2-S5-S6-S14-S15-S16-S17-S19 CLOSED -- S3-S4-S8-S12-S18-S20 OPEN - S0 in NPN position.
therefore preset in the following way:
- Power supply range 330VAC - 500 VAC; frequency 50Hz (dip-switch S20 open).
- Acceleration/deceleration ramp range: minimum 0,1 sec - maximum 1,5 sec - S3 open.
- 4 pole motor - S5 closed.
- NPN logic inputs (S0 in NPN position).
- Couple limitation disconnected S12 open.
- Minimum speed 0 rpm - Maximum speed 1400 rpm - slow speed 100 rpm
- acceleration and deceleration ramps 1,5sec.
- Zero relay intervention under 30 rpm.

DEMONSTRATIVE DIAGRAM

Backward / forward movement with pre-stop slowing for precision stopping with the brake command

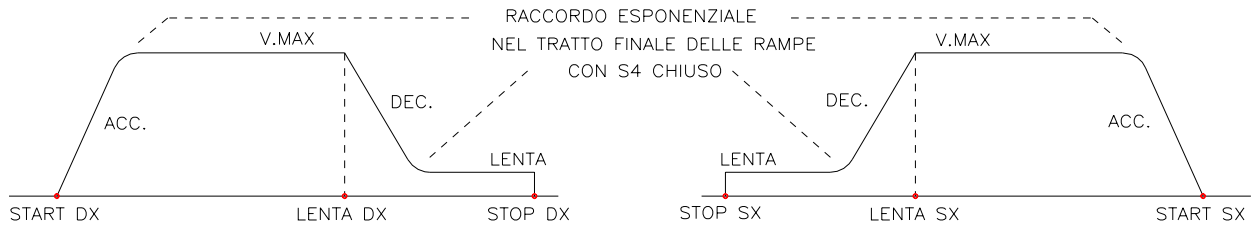

The diagram shows the speed profile for a trolley forward / backward movement with slowing and limit switch stop or proximity sensors. The acceleration / deceleration ramps are set by trimmers P2 - P3. The maximum speed is set by an external speed regulation potentiometer and the slow speed by trimmer P1. In this case the dip-switches are set in the following way:

Internal ramp regulation	S1 - S2 closed
Ramp speed 0,05 - 1 sec	S3 open
S ramp	S4 closed
4 pole motor	S5 closed
Soft response	S6 closed
External couple regulation excluded	S8 - S12 open
The other dip-switches S14-S15-S16-S17-S19 closed - S18 open - S0 in NPN position.	

The emergency group with opening contacts consists of:

- The motor thermic sensor (ST)
- the emergency relay opened in the emergency situation (RE)

N.B. For brake command it is wise to provide brake insertion disinsertion in accordance with load stop and start times in order to avoid the motor from going into traction with the brake still inserted and therefore risking the brake durability.

CONNECTION DIAGRAM

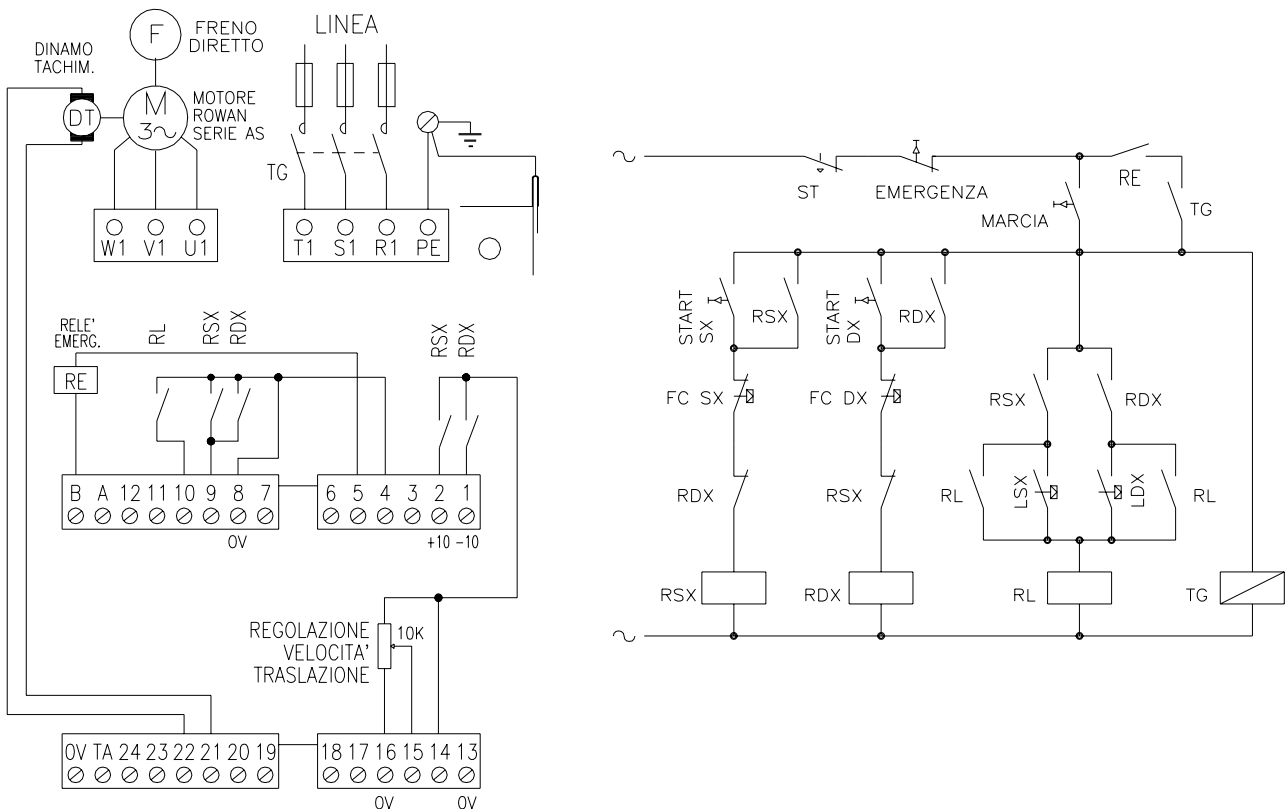

FCSX = limit stop SX
FCDX = limit stop DX

LSX = limit slowing SX
LDX = limit slowing DX

BLOCK DIAGRAM

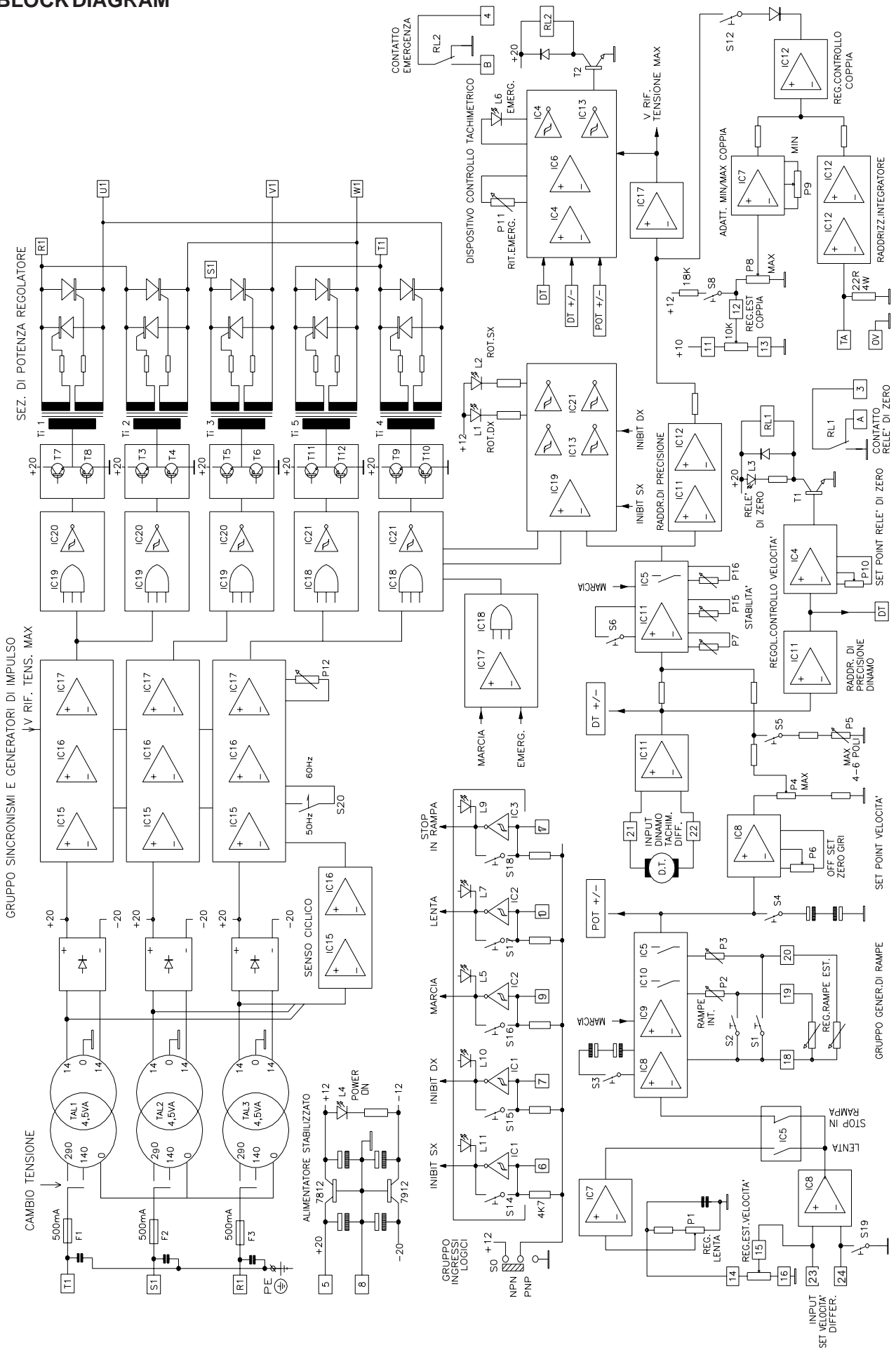

COMPONENTS LAYOUT

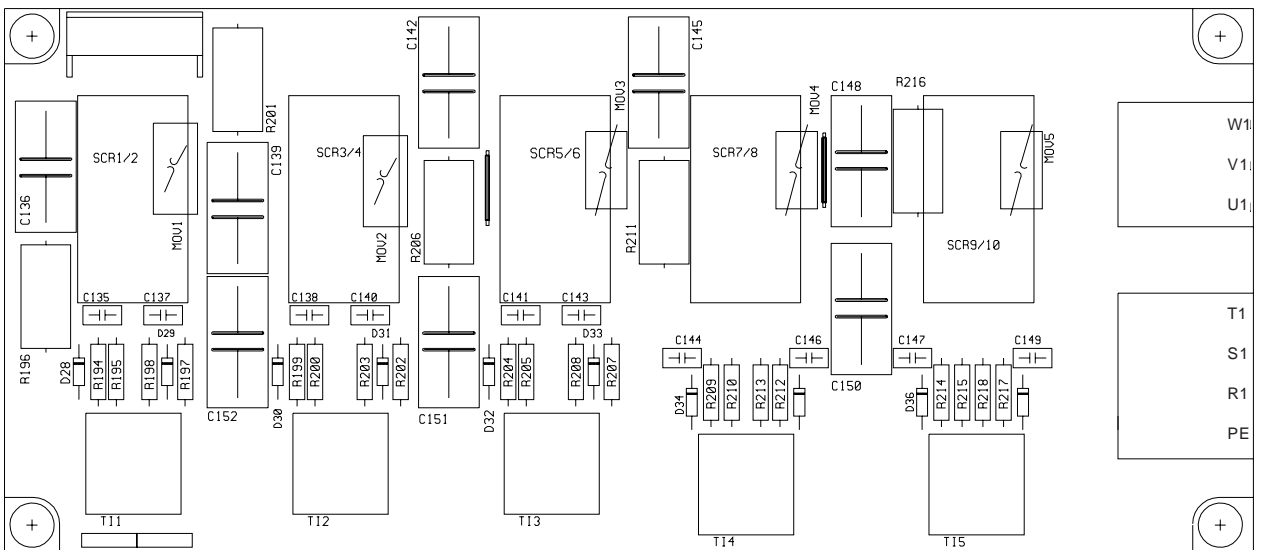
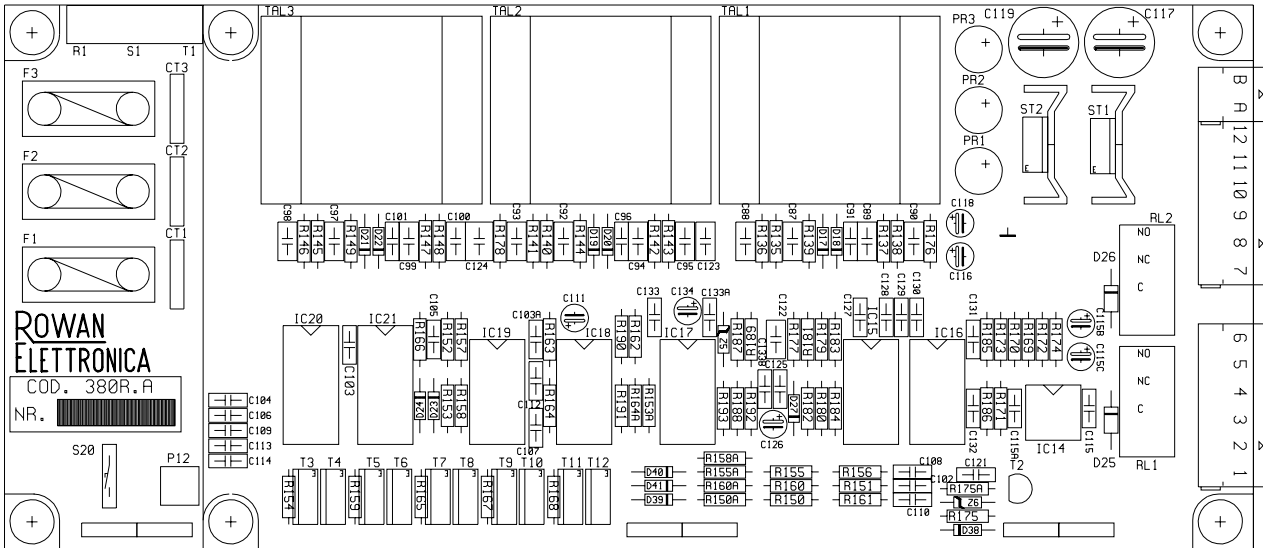
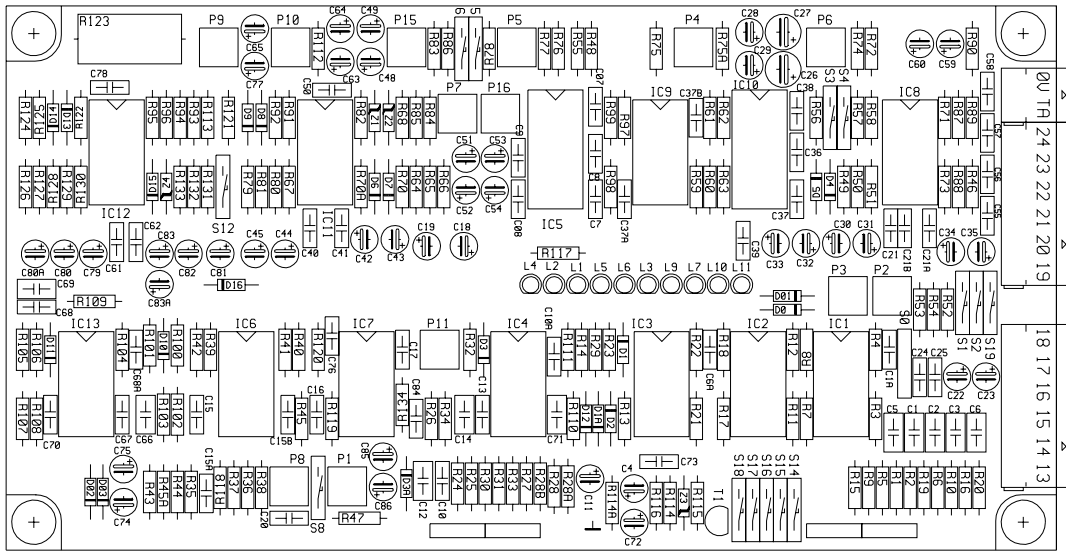

MAINTENANCE INSTRUCTIONS FOR THE S SERIES ROWAN MOTORS (HIGH SPEED TYPE)

The "ROWAN" S series motors, which have been designed to be piloted by voltage regulators with tachometrical feedback are particularly adapted, because of their inherent characteristics, to withstand repetitive power peaks and harsh braking. Being brushless their maintenance is reduced to a minimum and regards in particular the substitution of their bearings and the substitution of the tachometrical dynamo which occurs however after at least 5000 hours of operation.

Bearing and tachometrical dynamo substitution

Whenever it is necessary to dismount the motor in order to substitute the bearing, proceed in the following way:

- 1- remove the screws over the back vent shield or the cochlea fan and slide it off having first disconnected the wires from the service connector;
- 2- remove the tachometrical dynamo;
- 3- slide the tie-rods out and remove the back shield;
- 4- slide out the front shield which comes out followed by the rotor - which it blocks;
- 5- whenever the front bearing need removing, remove the dust guard screws and remove the segger ring (if present) from the axle;
- 6- slide the axle out from the bearing;
- 7- remove the segger ring (if present) that holds the bearing to the shield;
- 8- slide out the bearing and substitute it with one of similar type - Z C3 version, lubricated version with high temperature resistant grease;
- 9- the back bearing must be type 2RS C3.

If necessary, substitute the tachometrical dynamo when putting together the motor.

Brake maintenance

The brake and brake parts need frequent inspection. The wearing out of the brake depends on many factors, mainly on the inertial force of the load, the motor speed and the frequency of interventions. It is essential that the disc be substituted after a material consumption equal to 3mm.

Make sure that after inspection the air gap is correctly regulated. The inspection brake operations must be carried out with the brake electrically disconnected after checking the ground connection.

A good brake operation can be guaranteed only if original components, supplied by our firm, are used. For more detailed information contact the technical department at Rowan Elettronica.

N.B. When the air gap reaches a value equal to 0,7 mm it is necessary to bring such value to 0,2 mm

Counter-indications

The correct brake operation may only be guaranteed when working at room temperature. If the brake is operating in an oily environment or at temperatures which are different from room temperature, contact the technical department at Rowan Elettronica. If the brake is operating outdoor, exposed to humidity and low temperature, it is important to use the guard gasket supplied by Rowan, together with other protection if needed, in order to avoid that the disc friction material sticks to the braking surface when the brake is not being used for some time.

Spring brake or direct brake air gap regulation

If a **spring brake** is mounted and it needs an air gap regulation, proceed in the following way:

- 1- remove the connection bolts between the motor and the brake holder bell-shaped case;
- 2- slide the bell-shaped case out of the axle together with its brake;
- 3- remove the screws that secure the brake to the bell-shaped case,
- 4- slide the brake cable out of the terminal block;
- 5- slide the brake itself out of the bell-shaped case.

At this point it is possible to proceed with the regulation by turning the 3 bolts to obtain an air gap between 0,2 e 0,3mm. If the brake is provided with anti-dust ring, remove it in order to access the regulating bolts.

The spring brake is provided with the maximum braking couple, which may be reduced unscrewing the special nut, up to a maximum of 40%, making sure that it is not unscrewed until it leaves its seat.

If a **direct brake** is mounted, it is not necessary to dismount it, just check the air gap (maximum 0,3 mm) with a thickness gage through the side slots, and regulate by loosening the fixing grain on the brake holder hub if needed.

HIGH SPEED ROWAN MOTOR

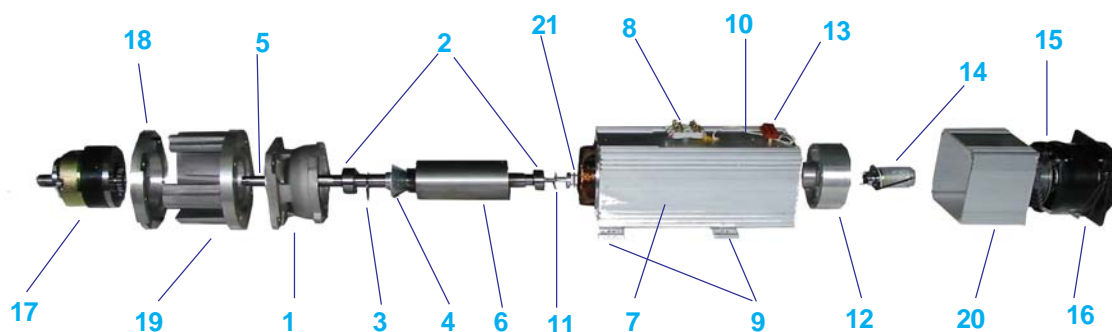

- 1 FRONT SHIELD (aluminium), which can be supplied in the following versions
 - FLANGED for B5, B3/B5 motors or with auxiliary electromagnetic brake motors;
 - FOOTED for B3 and B3/B5 motors.
- 2 FRONT AND REAR BEARING in C3 2RS.
- 3 SEEGER RING (63, 71 and 80 motors have this part only if equipped with brake).
- 4 CONIC DEFLECTER (aluminium).
- 5 MOTOR SHAFT (C40 Steel) normally supplied in the following versions:
 - STANDARD SHAFT for B3 or B5 motors without brake;
 - LONG SHAFT for motors equipped with brake.
 - REDUCED SHAFT (hardened steel) with reduced output dimensions.
- 6 MASSIVE ROTOR (iron) with cavities for air cooling passage.
- 7 STATOR FRAME composed by:
 - EXTERNAL RIBBED FRAME with the housing for power terminal board (Aluminium F91);
 - STATOR CORE (iron);
 - STATORIC WINDING (copper).
- 8 POWER TERMINAL BOARD for the connection of motor windings, with relative terminal board covering.
- 9 FEET for B3 or B3/B5 versions.
- 10 THERMIC SENSOR INSIDE WINDINGS
- 11 COMPENSATOR RING
- 12 REAR RING for rear bearing housing.
- 13 SERVICE TERMINAL BOARD for tachometer generator, ventilator and thermic sensor connection.
- 14 TACHOMETER GENERATOR TYPE 20VDC/2800 rpm, IP54, with relative joints; it can be supplied in 2 versions:
 - DIN55: for motors MEC 63, 71, 80, 90, 100
 - DIN70: for motors from MEC 112 to MEC 200L
- 15 INDEPENDENT VENTILATOR, for motor cooling, of 2 possible types *Axial* and *Cochlea*:
- 16 VENTILATOR COVERING for axial ventilator; not present on motors with cochlea ventilators.
- 17 ELECTROMAGNETIC BRAKE which can be supplied in the following 2 types: *spring/safety brake* (normally closed) and *direct brake* (normally open); the *spring/safety brake* can be equipped on request with a lever for manual opening.
- 18 FLANGED DISC OF BRAKE BEARING BELL separated from the brake bearing bell (19) only on motors Mec 90, 100, 112 and 112L.
- 19 BRAKE BEARING BELL (aluminium)
- 20 REAR SPACER
- 21 COUPLING

ROWAN MOTORS WORK CORRECTLY AT TEMPERATURES BETWEEN -15°C E +40°C; HIGHER TEMPERATURES CAN CAUSE FUNCTIONING ANOMALIES, AND, IF VERY HIGH, BREAKAGES. IT IS WISE, THEREFORE, TO LOCATE THEM AWAY FROM HEAT SOURCES AND GIVE THEM A MINIMUM AIR FLOW.

TRANSLATION OF THE TEXT IN THE DRAWINGS

- ACCELERAZIONE: ACCELERATION
 ALIMENTATORE STABILIZZATO: STABILISED POWER SUPPLY
 ASSORBIMENTO: ABSORPTION
 BIDIREZIONALE: BI-DIRECTIONAL
 CAMBIO TENSIONE: VOLTAGE CHANGER
 CON LINEA 220 IL COLLEGAMENTO E' A ...: CONNECTION WITH 220 V POWER LINE IS....
 CONTATTO RELE' DI EMERGENZA: EMERGENCY RELAY CONTACT
 CONTATTO RELE' DI ZERO: ZERO RELAY CONTACT
 COPPIA MASSIMA: MAXIMUM COUPLE
 COPPIA: COUPLE
 CORRENTE NOMINALE MOTORE: MOTOR NOMINAL CURRENT
 DALL'AZIONAMENTO: FROM THE DRIVER
 DECELERAZIONE: DECELERATION
 DINAMO TACHIMETRICA: TACH DYNAMO
 DISGIUNTORE TERMICO: THERMIC SWITCH
 DISPOSITIVO CONTROLLO TACHIMETRICO: TACHOMETRICAL CONTROL DEVICE
 DX.: CK.
 EMERGENZA: EMERGENCY
 FRENO A MOLLE: SPRING BRAKE
 FRENO DIRETTO: DIRECT BRAKE
 FUSIBILI RAPIDI TIPO GL CONSIGLIATI: RAPID GL TYPE FUSES RECOMMENDED

GIRI MASSIMI: MAXIMUM SPEED
GRUPPO INGRESSI LOGICI: LOGIC INPUT GROUP
GRUPPO SINCRONISMI E GENERATORI DI IMPULSO: SYNCRONISING GROUP AND IMPULSE GENERATOR
INDUTTANZA TRIFASE: THREE PHASE INDUCTANCE
INGRESSI: INPUT
INIBIT DX: RIGHT INHIBITION. **INIBIT SX:** LEFT INHIBITION.
INIBIZIONE ROTAZIONE DX: INHIBIT CLOCKWISE ROTATION
INIBIZIONE ROTAZIONE SX: INHIBIT ANTICLOCKWISE ROTATION
INPUT 0V LIMITAZIONE MASSIMA: MAXIMUM INPUT LIMIT 0VDC
INPUT 10V LIMITAZIONE MINIMA: MINIMUM INPUT LIMIT 10VDC
INPUT DIFFERENZIALE: DIFFERENTIAL INPUT
INPUT DINAMO TACH. DIFF.: DIFF. TACH. INPUT
INPUT SET VELOCITA' DIFFER.: DIFFERENTIAL INPUT
LENTA DX: SLOW SPEED DX **LENTA SX:** SLOW SPEED SX **LENTA:** SLOW
LEVA DI SBLOCCO: UNBLOCK LEVER
LINEA: LINE
MASSIMA VELOCITA' SENSO DI ROTAZIONE DX: MAXIMUM CLOCKWISE ROTATION SPEED
MASSIMA VELOCITA' SENSO DI ROTAZIONE SX: MAXIMUM ANTICLOCKWISE ROTATION SPEED
MASSIMO 4-6 POLI: MAX 4-6 POLES
MISURA MEC: MEC MEASUREMENT
MORSETTI O CONNETTORE COLLEGAMENTO FRENO: BRAKE CONNECTOR OR TERMINAL BLOCK
MORSETTIERA DI POTENZA: POWER CONNECTOR
MORSETTIERA SERVIZI: SERVICE TERMINAL BLOCK
MOTORE ROWAN SERIE AS: ROWAN AS SERIES MOTOR
OFF SET ZERO GIRI: ZERO REV. OFF SET
PESO: WEIGHT
POTENZA MASSIMA: MAXIMUM POWER
POTENZA MOTORE: MOTOR POWER
POTENZA VENTOLA: COOLING FAN POWER
PLC CON LOGICA NPN (PNP):: PLC WITH NPN (PNP) LOGIC
RACCORDO ESPONENZIALE: EXPONENTIAL CONNECTION
RADDRIZZATORE DI PRECISIONE DINAMO: PRECISION DYNAMO RECT.
RADDRIZZATORE DI PRECISIONE: PRECISION RECT.
RADDRIZZATORE INTEGRATORE: INTEGRATOR RECT.
RAMPA ACCELERAZIONE ESTERNA: EX. ACC. RAMP
RAMPA DECELERAZIONE ESTERNA: EX. DEC. RAMP
REG. CONTROLLO COPPIA: TORQUE REGULATION
REGOL. CONTROLLO VELOCITA': SPEED REGULATION
REGOLAZIONE COPPIA: TORQUE REGULATION
REGOLAZIONE ESTERNA CON POTENZIOMETRO: EXTERNAL POTENTIOMETER REGULATION
REGOLAZIONE ESTERNA CON SEGNALE DC: EXTERNAL DC SIGNAL REGULATION
REGOLAZIONE ESTERNA COPPIA: EX. TORQUE REG.
REGOLAZIONE ESTERNA VELOCITA': EX. SPEED REG.
REGOLAZIONE VELOCITA': SPEED REGULATION
RELÉ' DI ZERO ON: ZERO RELAY ON
RELE' EMERGENZA: EMERGENCY RELAY
ROTAZIONE DX: CLOCKWISE ROTATION
ROTAZIONE SX: ANTICLOCKWISE ROTATION
SENSO CICLICO: CYCLE SENSE
SENSO DI ROTAZIONE DX: CLOCKWISE ROTATION
SENSO DI ROTAZIONE SX: ANTICLOCKWISE ROTATION
SET POINT RELE' DI ZERO: SET POINT ZERO RELAY
SET VELOCITA': SPEED SET POINT
SEZIONE DI POTENZA REGOLATORE: POWER REGULATION SECTION
STABILITA': STABILITY
START DX: START CK. ROT. **START SX:** START ANTIC. ROT.
STOP DX: STOP CK ROT. **STOP IN RAMPA:** STOP IN RAMP **STOP SX:** STOP ANTICK. ROT.
SX: ANICK.
TEMPO ATTIVAZIONE FRENO: BRAKE ACTIVATION TIME
USCITE: OUTPUTS
V.RIF. TENSIONE MAX: REF. MAX VOLTAGE
VELOCITA' LENTA: SLOW SPEED
VELOCITA' LENTA DX: SLOW SPEED CK.
VELOCITA' LENTA SX: SLOW SPEED ANTICK.
VENTILATORE: FAN

CONFORMITY



Rowan Elettronica
 Motori, azionamenti, accessori e servizi per l'automazione



UNI EN ISO 9001