

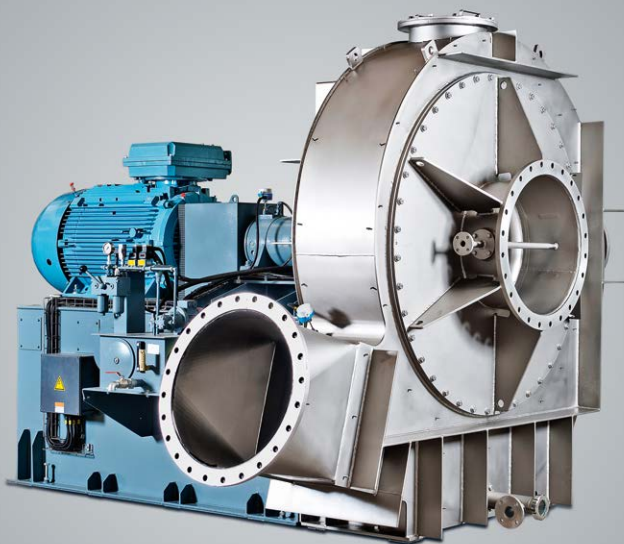

# BLOWERS & COMPRESSORS

MADE BY PILLER

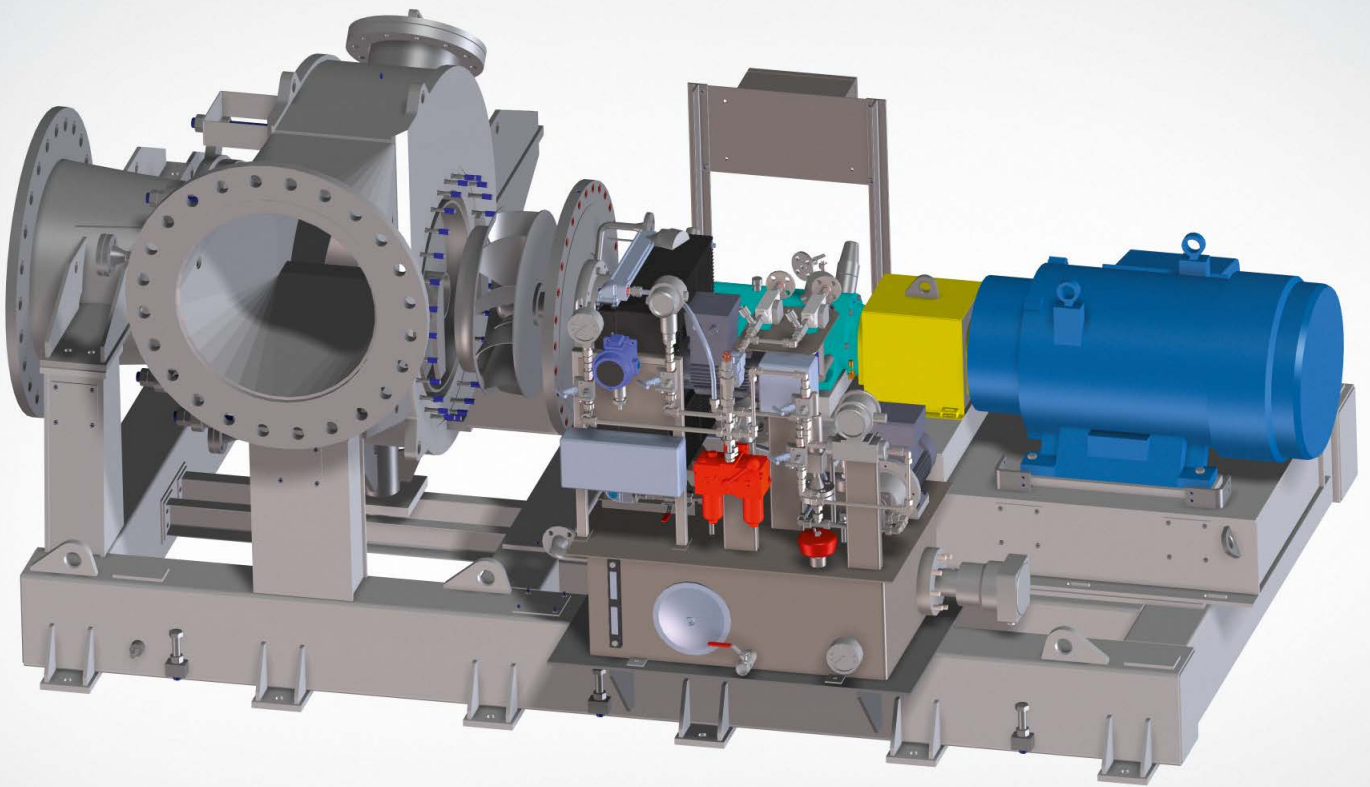





## CUTTING EDGE BLOWER SYSTEMS FOR PIONEERING PROCESS TECHNOLOGY

*PILLER blower systems allow for greater efficiency in process engineering: Today, our innovative high-performance centrifugal blowers perform the work of turbo compressors. We replace complex, difficult-to-maintain equipment with comparatively simple and more economical components. As a technology leader for blower systems in process technology, our continuous research and development constantly pushes the limits of what is technically feasible.*

*The result: save costs on the way to more efficiency and performance.*

# PILLER BLOWERS ACHIEVE MORE: OPTIMAL GEOMETRY FOR MAXIMUM PERFORMANCE

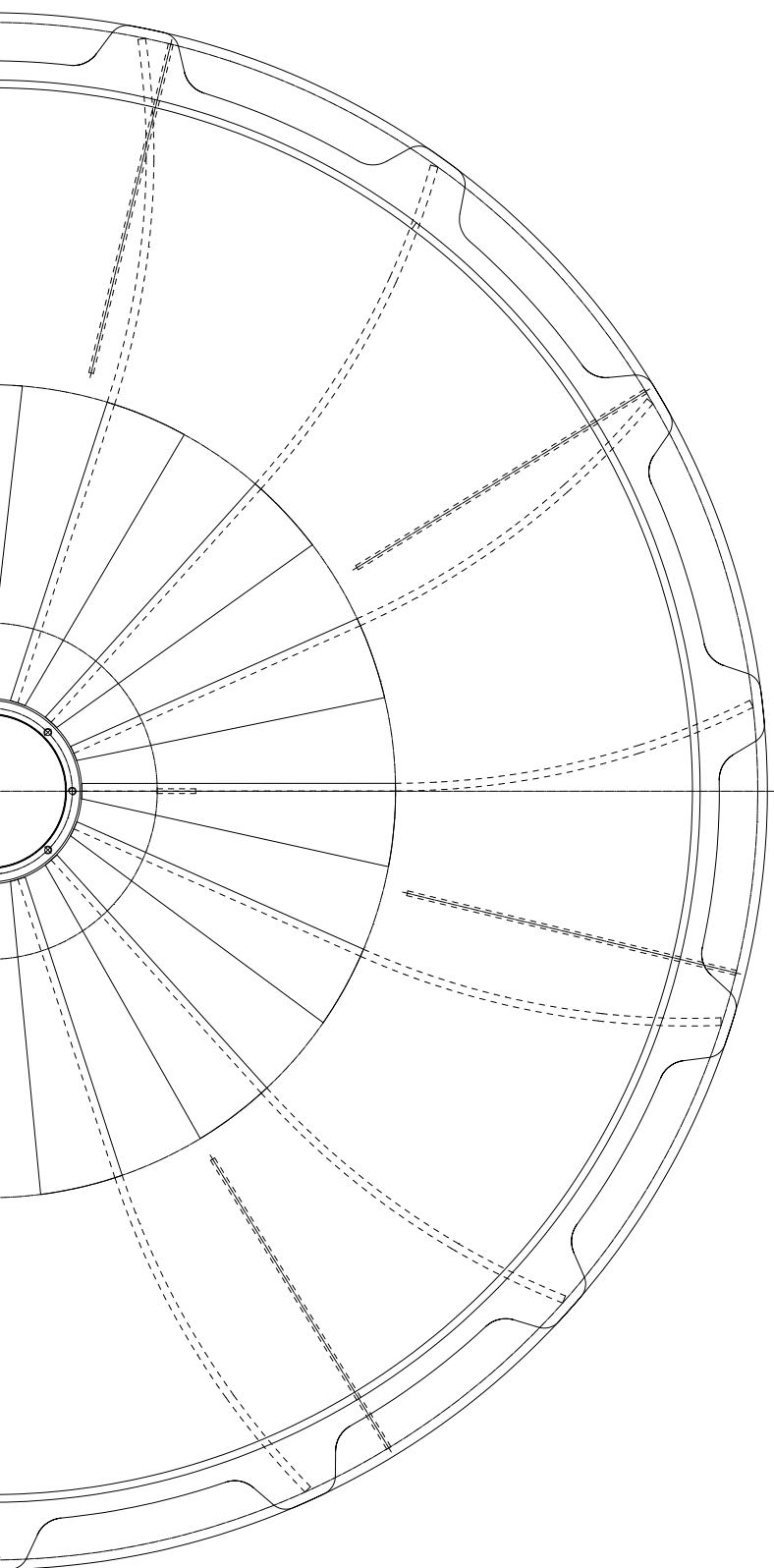

## **HIGHER DEGREE OF EFFICIENCY**

We increase the energy efficiency of your system – up to 88 percent efficiency is possible for PILLER blowers.

## **REDUCED COSTS**

Our optimized blower sizing allows for the smallest blowers which reduces costs.

## **LONGER SERVICE LIFE**

Due to superior quality, our blowers exhibit a longer service life – more than 30 years of operation is possible.

### Blower Performance Curve

Type 50770 KKXGAE 80710

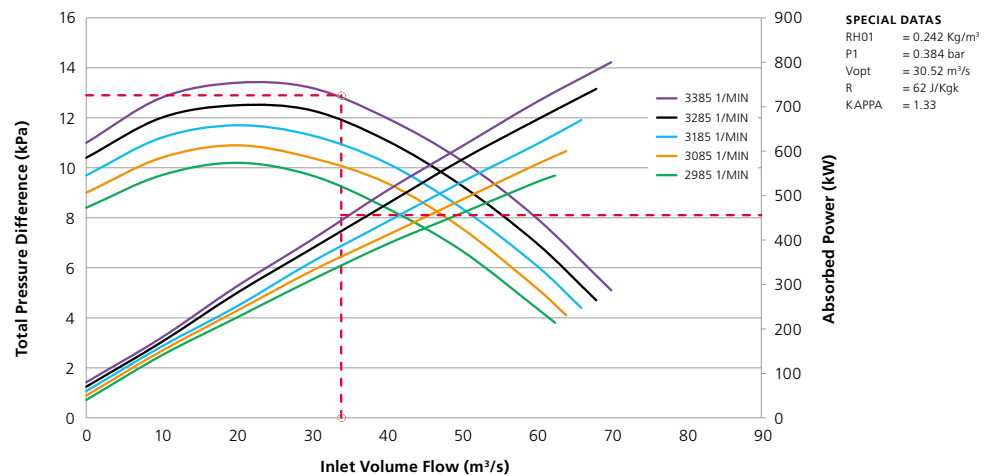

#### PILLER BLOWERS – A KEY COMPONENT FOR PROCESS TECHNOLOGY

Transport and compression of gases are core operations in process technology. Wherever these operations are used in process technology the blowers become critical to production. PILLER blower systems design and quality are a key factor in unit operation efficiency and cost-effectiveness. They form the vital core of an optimized technical solution for the end user's production process.

#### ENERGY AS A COST FACTOR – RESPONDING TO CHALLENGING MARKET CONDITIONS

Today, process designers and developers in process technology have a paramount priority: increase efficiency and reduce costs. In a world with continuously rising energy costs, process designers are always looking at efficiency. The trend here, e.g. in the evaporation process, is towards higher pressure rise and smaller heat exchange surfaces and less steam consumption. PILLER centrifugal blowers are designed specifically for increasing these pressures and temperatures efficiently – and thereby significantly reducing energy costs for a process.

#### MORE EFFICIENCY, COST OPTIMIZATION AND DURABILITY

PILLER offers more blower types than other blower manufacturers: Our many years of expertise enable us to always achieve an ideal interaction between efficiency, cost optimization and durability for unsurpassed performance with high ROI.

The key to this: intelligent design, high-precision manufacturing and superior service.

These characteristics provide process designers and end users with the necessary confidence on the way to an ideal overall system.



## PILLER INNOVATION GOES FAR BEYOND CURRENT STANDARDS – HIGH-QUALITY ENGINEERING BY THE TECHNOLOGY LEADER

### TECHNOLOGY LEADER FOR INNOVATIVE BLOWER SYSTEMS

PILLER is **the** technology leading manufacturer of blower systems in process technology. We have the world class know-how for industrial blower systems in the most challenging processes. We supply first-class quality in various fields of application, such as food, sugar, pulp & paper, chemical, refinery & petrochemical, water treatment, hot gases and metallurgy.

### FIRST CLASS QUALITY THAT SETS WORLD STANDARDS

PILLER can look back on long experience and excellent know-how gained in over 100 years of blower-manufacturing. PILLER expertise always stands for technical perfection – Made in Germany. Our combined expertise in R & D and high-end manufacturing sets the industry standard. We are the choice of customers worldwide who are working on the highest technical process level. We assure our excellent quality through numerous testing procedures – including non-destructive weld inspection, positive material identification, etc.

### OPTIMIZED DESIGN FOR EFFECTIVE PROCESS TECHNOLOGY

Extensive system knowledge is the foundation for our well-engineered solutions. Our engineers understand the conditions and challenges of our customers' overall processes. We have the competence to implement precise requirements in every detail. Precision, flexibility and speed are our benchmark – enabling our customers to profit from reduced planning costs and customized engineering.

### EASY ENGINEERING, EASY INTEGRATION

PILLER provides absolutely uncomplicated high-end blower systems that are easy to integrate into new and existing plants. State of the art and specifically tailored to the individual needs of our customers, they are easy to integrate, offer a long service life and require little maintenance – as uncomplicated as it gets.

# BLOWERS & COMPRESSORS ENGINEERED FOR ANY PROCESS

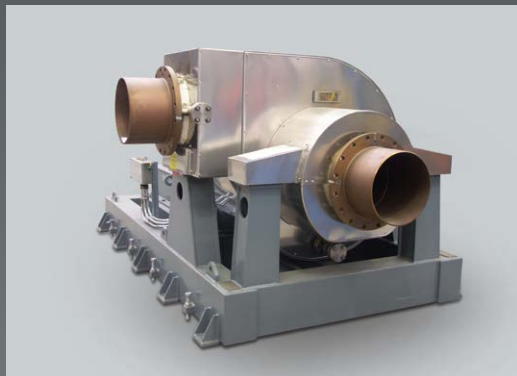
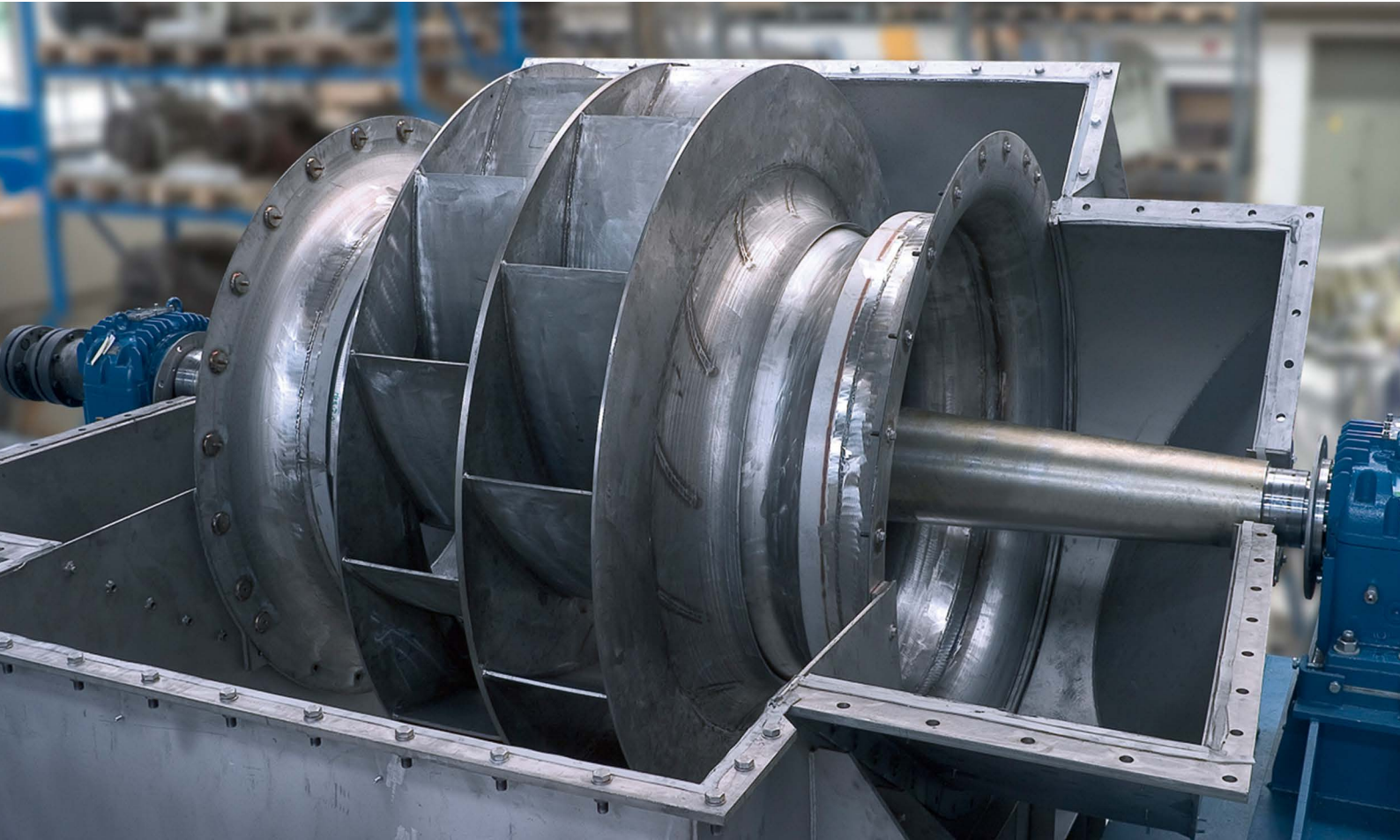



## OUR CORE COMPETENCIES – INTELLIGENT SOLUTIONS IN EACH COMPONENT

### 1. Housing – doubling the benefit by precision

We design the housing of our blower to exactly match the rotor. High efficiency and low noise emissions are the welcome result of this concept.

### 2. Rotors – variety with the right diameter

PILLER offers more than 2500 various rotor types and sizes. This diversity allows us to perfectly match even the most challenging performance requirements.

### 3. Bearings – PILLER's advantages

With the self-developed and patented squeeze oil damper PILLER has created a system that combines the simplicity and low cost of antifriction bearings with the performance of hydrodynamic fluid film bearings for supercritical speed. For rigid rotors, below critical operation plain antifriction bearings are used for PILLER machines.

### 4. Shaft sealing – sealed in every case

Simple felt rings, complex labyrinth seals, carbon ring seals or mechanical seals – we use a variety of sealing systems to meet every customer's specification.

### 5. Drives – available exactly to match the application

Electric motors usually drive our blowers. Steam turbines and diesel engines are also possible solutions. While planning the drives we fit them exactly to meet the process requirements.

### 6. Base frame – absolute precision

The mainstay of a blower is the motor base. We manufacture with millimeter precision to guarantee perfect concentricity of the blowers.



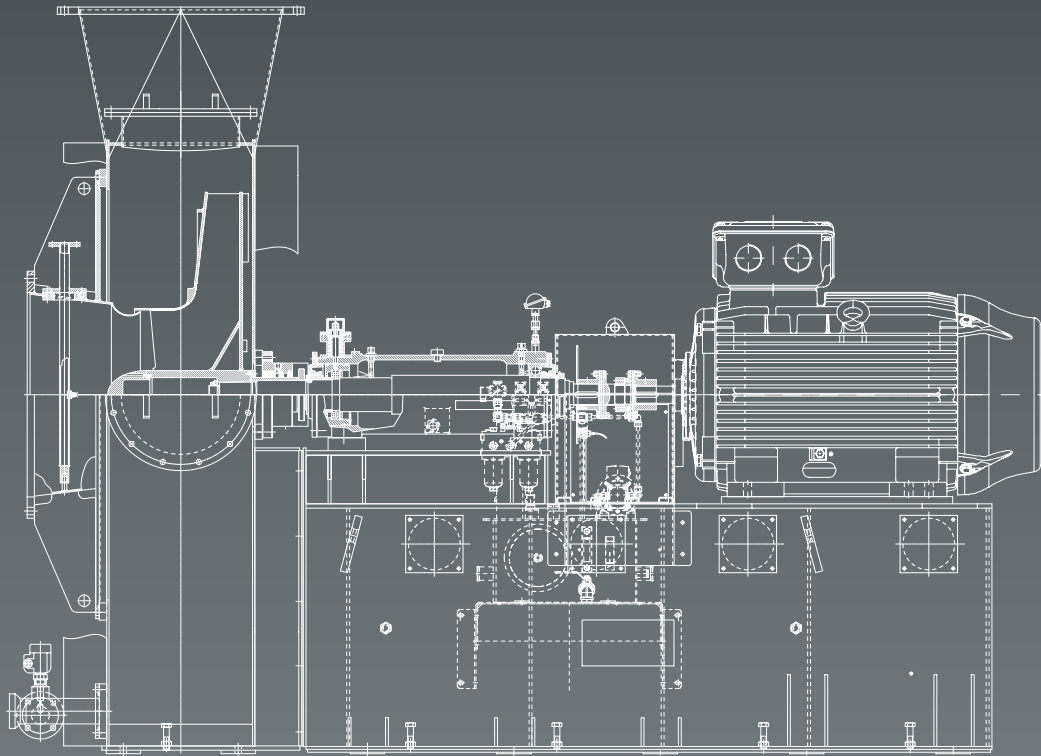

## ONE EXAMPLE OF INNOVATION – PILLER MVR BLOWER

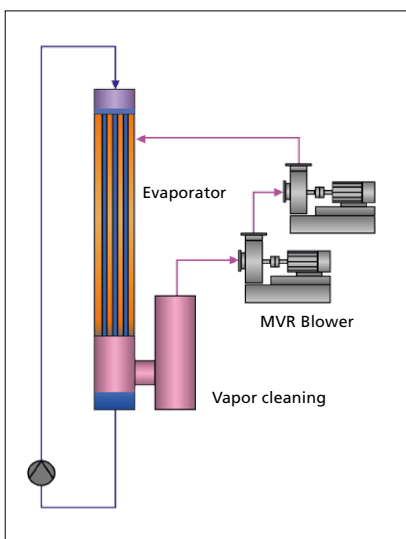

Evaporator with two-stage  
MVR Blowers system

### SIGNIFICANT LOWER ENERGY CONSUMPTION COMPARED TO A MULTI-EFFECT EVAPORATOR

Evaporation methods in process technology always have a high energy demand. Optimizing selection is especially worthwhile when taking rising energy costs into account: specifically for mechanical vapor recompression. PILLER has therefore developed high performance blowers that achieve a temperature increase of up to 10 Kelvin in a single stage.

MVR blowers are usefully employed in all processes that require temperature rise (Delta T) of 5 to 10 Kelvin. As an environmentally friendly multi-talent they can be individually adapted to the specific requirements of evaporation plants.

### ELEVATING TO A HIGHER ENERGY LEVEL

During the evaporation process, centrifugal blowers (MVR blowers) raise the vapor to a higher temperature level by increased pressure. The high-energy vapor passes back into the process as fresh heating steam. The energy contained in the inlet steam is not lost. Only the added energy for increasing the temperature is required.

Depending on the inlet temperature at the compressor connecting two or even three high performance MVR blowers in series, temperature increases of 18 Kelvin or 27 Kelvin can be achieved.

*In the early 80s, PILLER was the first manufacturer that introduced centrifugal blower systems for mechanical vapor recompression – initially exclusively in the milk industry.*

**INNOVATIVE HIGH-END DESIGN**

Today with its MVR blowers PILLER sets the highest standards for high-end design in special applications. Packed with numerous innovations and well thought-out down to the smallest detail. With standardized yet highly flexible solutions, we have created a basis for cost-effective MVR Blower solutions that can be quickly put into operation.

**KEY MVR BLOWER FACTS**

- Vacuum-proof housing design for 0.1 bar (abs.)
- Rotors for extremely high tip speeds
- Water injection for rotor cleaning and steam desuperheating during operation
- Low-wear floating carbon ring seals
- Optional operation in series or parallel
- Patented squeeze oil damping for smoothest operation

**EXAMPLE: DAIRY INDUSTRY**

Our MVR blowers are suitable for many industries – for example the dairy industry, where our blowers were initially used. One example of installations uses our Type 52573 KKXGAE 80900.

Technical Details	
Medium	Steam
Motor Power	560 kW
Temperature Rise	4,85 °C
Differential Pressure	64,81 mbar
Impeller Speed	3000 U/min
Efficiency	86 %
Volume Flow	53628 m <sup>3</sup> /s
Density	0,1709 kg/m <sup>3</sup>





### OTHER APPLICATIONS

Continuous development and optimizations lead to a large variety of customized applications implemented in different sectors such as

**Food:**

- Milk/Whey, Sugar, Yeast, Fruit Juices etc.

**Water Treatment:**

- Saline Water, Seawater Desalination, Wastewater Cleaning

**Pharmaceutical:**

- Blood Plasma, Distilled Water

**Chemistry:**

- Citric Acid, Acetic Acid, Sulphuric Acid
- Wood Drying, Pellets Drying, Peat Drying, Paper Drying

**Petrochemistry:**

- Oil Refining
- Propylen Production

