

**Features**

- 1-channel isolated barrier
- 24 V DC supply (Power Rail)
- Input 2-wire and 3-wire SMART transmitters and 2-wire SMART current sources
- Signal splitter (1 input and 2 outputs)
- Dual output 0/4 mA ... 20 mA
- Terminal blocks with test sockets
- Up to SIL3 acc. to IEC 61508

**Function**

This isolated barrier is used for intrinsic safety applications. The device supplies 2-wire and 3-wire SMART transmitters in a hazardous area, and can also be used with 2-wire SMART current sources.

It transfers the analog input signal to the safe area as two isolated current values.

Digital signals may be superimposed on the input signal in the hazardous or safe area and are transferred bi-directionally.

If the HART communication resistance in the loop is too low, the internal resistance of 250 Ω between terminals 8, 9 and 11, 12 can be used.

Test sockets for the connection of HART communicators are integrated into the terminals of the device.

**Application**

The device supports the following SMART protocols:

- HART
- BRAIN
- Foxboro

**Assembly**

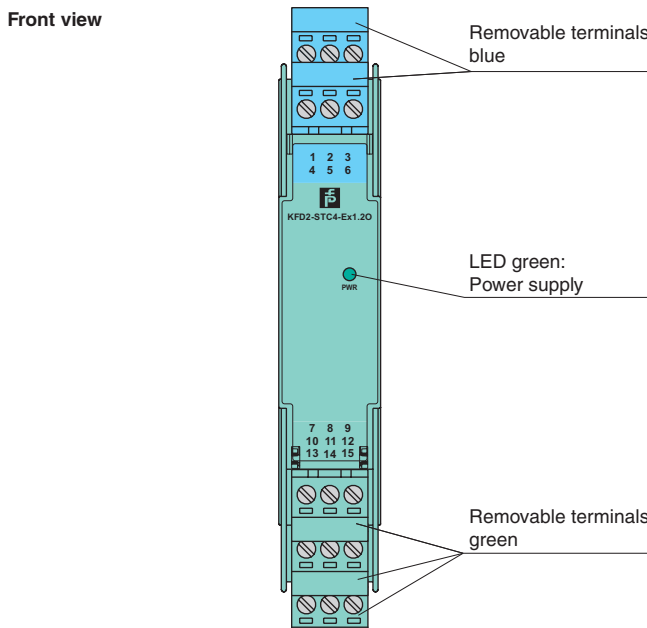

**Connection**

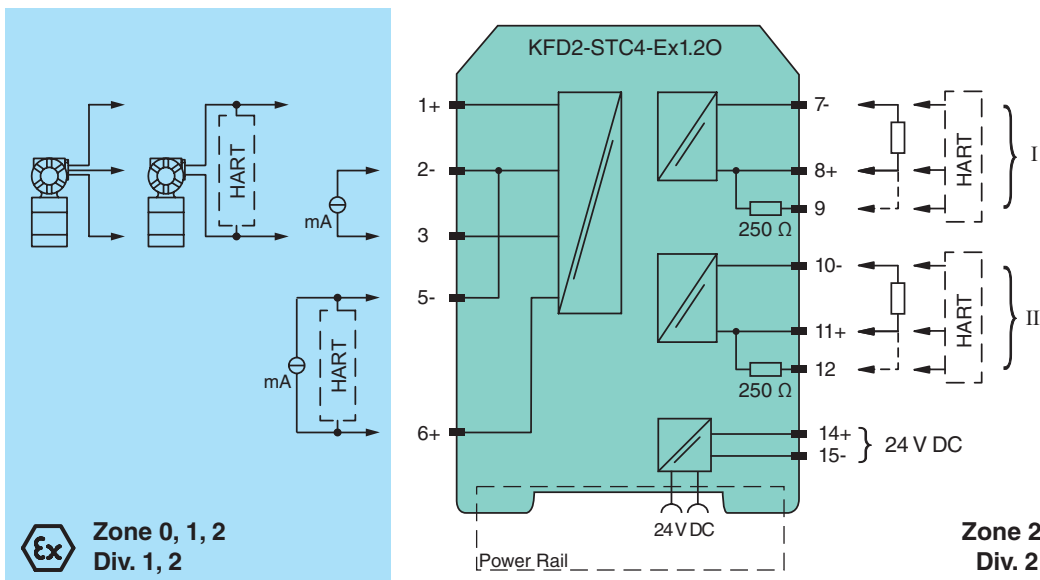

Release date 2014-12-01 16:23 Date of issue 2014-12-01 12:581\_eng.xml

**Ex** Zone 0, 1, 2  
Div. 1, 2

**Zone 2**  
**Div. 2**

<b>General specifications</b>		
Signal type		Analog input
<b>Supply</b>		
Connection		Power Rail or terminals 14+, 15-
Rated voltage	$U_N$	20 ... 35 V DC
Ripple		within the supply tolerance
Power loss		1.9 W
Power consumption		2.5 W
<b>Input</b>		
Connection		terminals 1+, 2-, 3 or 5-, 6+
Input signal		0/4 ... 20 mA
Voltage drop		$\leq 2.4$ V at 20 mA (terminals 5, 6)
Input resistance		$\leq 76 \Omega$ terminals 2-, 3 ; $\leq 500 \Omega$ terminals 1+, 3 (250 $\Omega$ load)
Available voltage		$\geq 16$ V at 20 mA terminals 1+, 3
<b>Output</b>		
Connection		terminals 7-, 8+,9; 10-, 11+,12
Load		0 ... 550 $\Omega$
Output signal		0/4 ... 20 mA (overload > 25 mA)
Ripple		$\leq 50 \mu\text{A}_{\text{rms}}$
<b>Transfer characteristics</b>		
Deviation		at 20 °C (68 °F), 0/4 ... 20 mA $\leq 10 \mu\text{A}$ incl. calibration, linearity, hysteresis, loads and fluctuations of supply voltage
Influence of ambient temperature		0.25 $\mu\text{A}/\text{K}$
Frequency range		field side into the control side: bandwidth with 0.5 $V_{\text{pp}}$ signal 0 ... 7.5 kHz (-3 dB) control side into the field side: bandwidth with 0.5 $V_{\text{pp}}$ signal 0.3 ... 7.5 kHz (-3 dB)
Settling time		200 $\mu\text{s}$
Rise time/fall time		20 $\mu\text{s}$
<b>Electrical isolation</b>		
Output/power supply		functional insulation, rated insulation voltage 50 V AC
Output/Output		functional insulation, rated insulation voltage 50 V AC
<b>Directive conformity</b>		
Electromagnetic compatibility		
Directive 2004/108/EC		EN 61326-1:2006
<b>Conformity</b>		
Electromagnetic compatibility		NE 21:2006
Degree of protection		IEC 60529:2001
Protection against electrical shock		UL 61010-1:2012
<b>Ambient conditions</b>		
Ambient temperature		-20 ... 60 °C (-4 ... 140 °F)
<b>Mechanical specifications</b>		
Degree of protection		IP20
Mass		approx. 200 g
Dimensions		20 x 124 x 115 mm (0.8 x 4.9 x 4.5 in) , housing type B2
Mounting		on 35 mm DIN mounting rail acc. to EN 60715:2001
<b>Data for application in connection with Ex-areas</b>		
EC-Type Examination Certificate		BAS 99 ATEX 7060 , for additional certificates see <a href="http://www.pepperl-fuchs.com">www.pepperl-fuchs.com</a>
Group, category, type of protection		$\text{Ex}$ II (1)G [Ex ia Ga] IIC , $\text{Ex}$ II (1)D [Ex ia Da] IIIC
Input		[Ex ia Ga] IIC, [Ex ia Da] IIIC
<b>Supply</b>		
Maximum safe voltage	$U_m$	250 V (Attention! The rated voltage can be lower.)
<b>Equipment</b>		
Voltage	$U_o$	25.4 V
Current	$I_o$	86.8 mA
Power	$P_o$	551 mW
<b>Equipment</b>		
Current $I_o$ /Current $I_i$		74 mA / 115 mA
Current	$I_i$	115 mA
Voltage	$U_o$	3.5 V
Current	$I_o$	74 mA
Power	$P_o$	64 mW
<b>Equipment</b>		
Voltage	$U_i$	30 V
Current	$I_i$	115 mA
Voltage	$U_o$	25.4 V

Release date 2014-12-01 16:23 Date of issue 2014-12-01 12:581\_eng.xml

Current	$I_o$	115 mA
Power	$P_o$	584 mW
Equipment		terminals 5-, 6+
Voltage	$U_i$	30 V
Current	$I_i$	115 mA
Voltage	$U_o$	8.7 V
Current	$I_o$	0 mA
Output		
Maximum safe voltage	$U_m$	250 V (Attention! The rated voltage can be lower.)
EC-Type Examination Certificate		DMT 01 ATEX E 133
Group, category, type of protection		⊕ I (M1) [Ex ia] I
Statement of conformity		TÜV 99 ATEX 1499 X , observe statement of conformity
Group, category, type of protection, temperature class		⊕ II 3G Ex nA II T4 [device in zone 2]
Electrical isolation		
Input/Output		safe electrical isolation acc. to IEC/EN 60079-11, voltage peak value 375 V
Input/power supply		safe electrical isolation acc. to IEC/EN 60079-11, voltage peak value 375 V
Directive conformity		
Directive 94/9/EC		EN 60079-0:2012 , EN 60079-11:2012 , EN 60079-15:2010 , EN 50303:2000
<b>International approvals</b>		
UL approval		
Control drawing		116-0173 (cULus)
IECEX approval		IECEX BAS 04.0016
Approved for		[Ex ia Ga] IIC, [Ex ia Da] IIIC, [Ex ia Ma] I
<b>General information</b>		
Note		Both output loads must be connected to ensure complete and correct operation within the technical specification.
Supplementary information		EC-Type Examination Certificate, Statement of Conformity, Declaration of Conformity, Attestation of Conformity and instructions have to be observed where applicable. For information see <a href="http://www.pepperl-fuchs.com">www.pepperl-fuchs.com</a> .

## Accessories

### Power feed module KFD2-EB2

The power feed module is used to supply the devices with 24 V DC via the Power Rail. The fuse-protected power feed module can supply up to 150 individual devices depending on the power consumption of the devices. Collective error messages received from the Power Rail activate a galvanically-isolated mechanical contact.

### Power Rail UPR-03

The Power Rail UPR-03 is a complete unit consisting of the electrical insert and an aluminium profile rail 35 mm x 15 mm. To make electrical contact, the devices are simply engaged.

### Profile Rail K-DUCT with Power Rail

The profile rail K-DUCT is an aluminum profile rail with Power Rail insert and two integral cable ducts for system and field cables. Due to this assembly no additional cable guides are necessary.



*Power Rail and Profile Rail must not be fed via the device terminals of the individual devices!*