

Operating instruction english

Revision	G
Date	21.01.2015
Issuer	NH

This operating instruction is not
subject to the updating

Self sealing coupling Medium Pressure Series

1-MD-006-0-.....-..

1-MD-006-2-.....-..

1-MD-007-0-.....-..

1-MD-007-2-.....-..

1-MD-012-0-.....-..

1-MD-012-2-.....-..

1-MD-019-0-.....-..

1-MD-019-2-.....-..

optional features:

OV

SI

GG (only MD-019)

EX

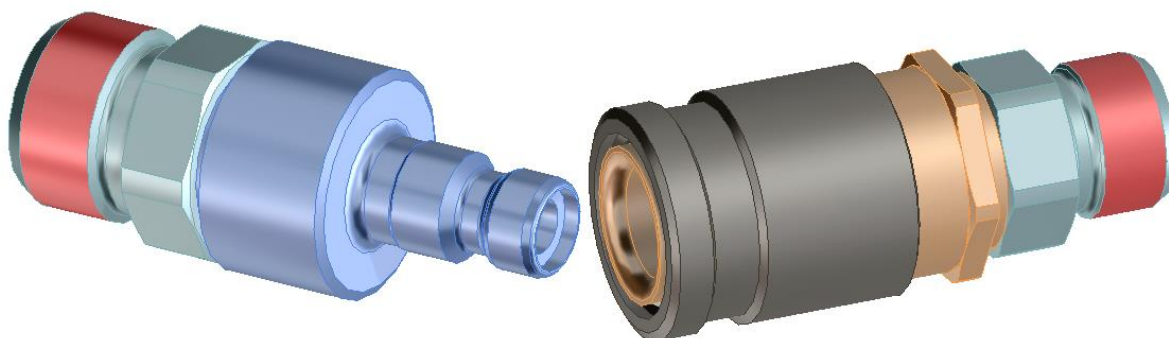

This coupling is a quality product, in which special attention has been paid to high functionality, ease of operation, safety and reliability. As an item of technical equipment this coupling is intended for use in the commercial, industrial area and for operators, who have been trained by specialists in the handling of technical systems / tools.

Customer care:

As part of our individual customer care we will be happy to assist you in questions relating to use and operation and on any problems encountered.

Service and maintenance:

In order to maintain the high technical performance capability and reliability of your coupling over many years, we recommend regular inspection and maintenance.

We can thereby offer you optimum support by our Customer Service department and the conclusion of a service and maintenance contract. Please ask for a quotation.

List of Contents

1 List of Contents

1	LIST OF CONTENTS	3
2	GENERAL.....	5
3	WARRANTY.....	6
3.1	GENERAL	6
3.2	REPLACEMENT PARTS	6
4	SAFETY INSTRUCTIONS	7
5	PRODUCT DESCRIPTION OF THE SELF SEALING COUPLING	8
5.1	INTENDED USE	8
5.2	TECHNICAL DATA	9
5.3	MATERIAL DEPENDENT DIFFERENCES	10
5.3.1	MD-006	10
5.3.2	MD-007	10
5.3.3	MD-012	10
5.3.4	MD-019	10
5.4	OPTIONAL FEATURES.....	11
5.5	EXTENDED PRODUCT DESCRIPTION FOR APPLICATION ACC. TO ATEX-GUIDE LINE 94/9/EG (SPECIAL DESIGN EX):	12
5.5.1	General.....	12
5.5.2	Extended marking	12
6	INSTALLATION INSTRUCTION.....	13
6.1	GENERAL	13
6.2	EXTENDED INSTALLATION INSTRUCTION FOR APPLICATION ACC. TO ATEX-GUIDELINE 94/9/EG	14
6.2.1	Details for safe operation.....	14
6.2.2	Details for safe installation	14
6.2.3	Details for a safe application area	14
7	OPERATING INSTRUCTION	15
7.1	CONNECTION PROCESS.....	15
7.2	DISCONNECTION PROCESS	15
7.3	SAFETY LOCKING DEVICE SI (SUPPLEMENTARY EQUIPMENT).....	16
7.3.1	Coupling process.....	16
7.3.2	Decoupling process.....	16
8	MAINTENANCE INSTRUCTION.....	17
8.1	MAINTENANCE:	17
8.2	FUNCTIONAL TESTING:.....	18
9	TEST.....	19
9.1	IMMERSION TEST	19
9.1.1	Test setup of the connected state (schematic view)	19
9.1.2	Test procedure.....	19
9.1.3	Test disconnected.....	20
9.1.4	Test setup of the disconnected state (schematic view)	20
9.1.5	Test procedure.....	20
9.1.6	Test result.....	20

List of Contents

9.2	PRESSURE TEST.....	21
9.2.1	<i>Test setup of connected state (schematic view)</i>	21
9.2.2	<i>Test procedure</i>	21
9.2.3	<i>Test disconnected</i>	22
9.2.4	<i>Test setup of the disconnected state (schematic view)</i>	22
9.2.5	<i>Test procedure</i>	22
9.2.6	<i>Test result</i>	23
9.3	DOCUMENTATION	23
10	LUBRICATION !	24
11	STORAGE	24
12	SHUT-DOWN	24
13	INDEX	25

2 General

This operating instruction contains all regulations for operation, commissioning and maintenance of the coupling.

All information and notes in this operating instruction were collated while taking into consideration the valid regulations, the current engineering related status of development as well as our many years of experience and acquired knowledge.

Translations of this operating instruction were also produced according to the best of knowledge. However, we cannot assume liability for any translation errors. The German version provided for this operating instruction is considered the authoritative version.

The actual scope of delivery can deviate from the explanations and graphic representations described herein under certain circumstances, e.g. in the case of special designs, utilization of additional order options or because of state-of-the-art technical alterations. If you have any questions, please contact WALTHER-PRÄZISION.



This operating instruction must be read carefully before starting work on or with the equipment, in particular before commissioning! WALTHER-PRÄZISION assumes no liability for damage or faults arising from non-compliance with the instructions in this operating instruction.

The operating instruction must be kept directly with the equipment and be accessible to all persons who work on or with the equipment. It is not permitted for the operating instruction to be passed to third parties and if applicable this will incur damage compensation. All other rights reserved.

Before commissioning the device must be checked for being not defective and its technically perfect function.

The German version is the original.

We reserve the right to make technical alterations to the product within the context of improving the usage properties and further development.

The operating instruction remains our property.

Any reproduction, use by or communication to third parties incurs a penalty and will be pursued by court action (copyright law against unfair competition, BGB [German Civil Code]). All rights reserved in the case of a patent award (Paragraph 7, Section. 1 of the patent law - PG) or entry as a patented design (Paragraph 5, Section 4 of the patented design law - GMG).

3 Warranty

3.1 General

The warranty is in accordance with:

The regulations agreed upon in the purchase contract and

The "General terms and conditions for delivery and service" of WALTHER-PRÄZISION using the version valid at the time the purchase contract came into force.

Generally excluded from the warranty are consumables.

Typical consumables in products from WALTHER-PRÄZISION are, for example:

- Seals
- Springs
- Electro plug contacts
- Electrical cables and hoses which are subject to regular alternating bending or torsional stresses.

Components that are not normally subject to wear under the conditions to be expected (environmental and usage) may become consumables if the described product is not operated according to the intended purpose or is operated with a disregard for the specifications in the operating instructions.

For example, electrical cables with sheathing that has been destroyed by extreme exposure to welding sparks would not fall under the warranty.

In addition, wear to other components caused by unusual environmental conditions, not expressly coordinated with WALTHER-PRÄZISION, for example, high temperatures, dusts with an abrasive effect, high humidity or corrosive vapours and gases are not covered by the warranty.

Cycle, time or load dependant specifications for the replacement of certain components of the described product within the framework of maintenance are not warranty-relevant durability statements, they are instead recommendations designed as preventive maintenance to avoid standstill times during production.

3.2 Replacement parts

Warning!

The use of non-Walther-parts can cause personal injuries, death as well as material damage.

Only original parts from WALTHER-PRÄZISION are to be used.
These are to be installed according to their intended purpose.

When using third-party items or parts that have not been approved by WALTHER-PRÄZISION, all warranties, guarantees and service claims are voided without notification.

Safety instructions

4 Safety instructions

Using these operating instruction does not release the customer from his obligation to comply with the pertinent work safety regulations e.g. operational safety regulations, etc. The duty to take due care by the operator of the couplings includes planning measures to ensure proper operation and monitoring their implementation.



Hazard notes

If the wrong product has been selected or if there is improper use or maintenance has been omitted, then hazards arise and personal injuries and material damage can occur from:

- hazardous emission of fluid or individual particles/coupling parts.
- function impairments of connected systems or tools.
- The metal parts of coupling and adaptor are not thermally protected. You can be burned if you touch these parts at high media temperatures. According to the ambient temperature valve lever and ring grip can also become unbearably hot. For that reason suitable, sufficiently long protective gloves should be worn.



The operator must in particular make sure that

- the materials, designs and seals which were used in the coupling halves were selected by in a responsible manner of customer designers, purchasers or operators by themselves for their medium, pressure and flow combinations.
- the couplings are only used according to the intended purpose.
- the couplings are only operated in a perfect, functioning condition.
- the operating instruction is always in a legible condition and is available in its entirety to operating personnel.
- the operating personnel are sufficiently acquainted with the working method and the safety notes for the coupling.
- no safety devices must be removed and/or deactivated during operation of the couplings.
- before installing or dismantling the couplings, you have made sure that the couplings have not been pressurized.



After completing assembly and installation work and before commissioning the coupling, the following items have to be observed:

Check once again that all screw connections are securely fitted.

Before commissioning the couplings, a function test must be carried out (see maintenance and function test).

Product description of the self sealing coupling

5 Product description of the self sealing coupling

Coupling connection consists of:

- | | |
|-------------------------|---------------------|
| - self sealing coupling | 1-MD-006-0-.....-.. |
| - self sealing adaptor | 1-MD-006-2-.....-.. |
| - self sealing coupling | 1-MD-007-0-.....-.. |
| - self sealing adaptor | 1-MD-007-2-.....-.. |
| - self sealing coupling | 1-MD-012-0-.....-.. |
| - self sealing adaptor | 1-MD-012-2-.....-.. |
| - self sealing coupling | 1-MD-019-0-.....-.. |
| - self sealing adaptor | 1-MD-019-2-.....-.. |

In case that both coupling halves are not connected they should be protected against external dirt and/or damages if required.

For that purpose dust cap and dust plug are available.

Possible combinations:

- | | |
|-----------------------|------------|
| self sealing coupling | 1-MD-...-0 |
| with | |
| dust plug | 1-MD-...-6 |
| self sealing adaptor | 1-MD-...-2 |
| with | |
| dust cap | 1-MD-...-5 |

5.1 Intended use

- Coupling is only used as connection of two lines.
- Connection and disconnection process is carried out by hand.
- The coupling is especially suitable for the following media / applications, provided the correct coupling material as well as sealing material were chosen:
 - air
 - water
 - hydraulic oil
- For all other possible applications, Walther-Präzision should be consulted.

Product description of the self sealing coupling

5.2 Technical data

CAUTION

For normed threaded connections, when specifying the operating pressure, the highest permitted operating pressure of the connection must be taken into account!

Differing higher or lower operating pressures are possible according to material characteristics or the connection. This operating pressure is to be taken from the project-specific documentation.

	max. static Working pressure steel (bar)	max. static Working pressure brass (bar)	max. static Working pressure st. st. (bar)	Min. burst pressure for steel (bar)	Cv-value
MD-006	200	40	100	1000	0,73
MD-007	250	40	100	800	1,07
MD-012	250	40	100	750	3,25
MD-019	250	40	50	750	7,5

Temperature

The permissible working temperature ranges usually between +5 °C and +70 °C. Deviating working temperatures are listed separately for specific projects.

- The coupling is not determined for any types of use and technical values other than those listed here.
- Safe operation is not guaranteed if the coupling is used contrary to its intended use and technical values
- The operator of the coupling is responsible for all personal injuries or material damage that occur from non-intended use and disregard of the technical values; the manufacturer assumes no responsibility in these cases.

Product description of the self sealing coupling

5.3 Material dependent Differences

5.3.1 MD-006

end plug seal

material **Steel:** O-Ring Ø1.5 und anti extrusion ring
material **brass and Stainless steel:** O-Ring Ø1.78 without anti extrusion ring

valve

material **Steel:** MD-006 valve
material **brass and Stainless steel:** LP-006 valve

5.3.2 MD-007

end plug seal

material **Steel:** O-Ring Ø1.5 und anti extrusion ring
material **brass and Stainless steel:** O-Ring Ø1.78 without anti extrusion ring

valve

material **Steel:** MD-007 valve
material **brass and Stainless steel:** LP-007 valve

5.3.3 MD-012

end plug seal

material **Steel:** O-Ring Ø1.5 und anti extrusion ring
material **brass and Stainless steel:** O-Ring Ø1.78 without anti extrusion ring

valve

material **Steel:** MD-012 valve
material **brass and Stainless steel:** LP-012 valve

5.3.4 MD-019

end plug seal

material **Steel:** O-Ring Ø2.2 in PTFE
material **brass and Stainless steel:** O-Ring Ø2.62

valve

material **Steel:** MD-019 valve
material **Stainless steel:** LP-019-Z87 valve
material **brass:** LP-019 valve

Product description of the self sealing coupling

5.4 Optional Features

OV = without valve (e.g.: 1-MD-006-0-.....-OV
1-MD-006-2-.....-OV)

SI = with protection by safety locking device (see point 5)
(e.g.: 1-MD-006-0-.....-SI)

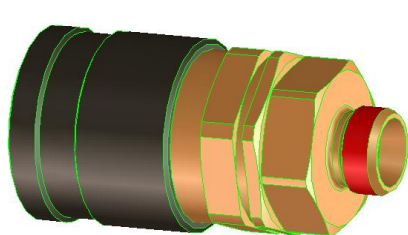

without SI

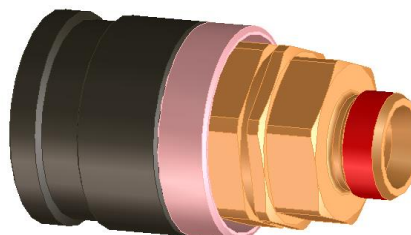

with SI

GG = with ring grips (aluminium cast)
only **MD-019** (e.g.: 1-MD-019-0-.....-GG)



EX = ATEX – version

Product description of the self sealing coupling

5.5 Extended product description for application acc. to ATEX-guide line 94/9/EG (special design EX):

5.5.1 General

Only non-sparkling materials may be used.
Non-sparkling materials are 1.4305 or equivalent materials.
Furthermore brass with different surfaces (f. ex. chrome-plated, nickel-plated).

Further on it must be assured that the seal is resistant against and suitable for the flowing through media. Also the temperature resistance of the seals must be guaranteed. This must also be considered for the marking acc. to chapter 5.5.2.

When assembled the self sealing couplings have an electrically conductive connection.

5.5.2 Extended marking

The coupling fittings are marked with



As the surface temperature of the self-sealing couplings are determined by the temperature of the fluids, the temperature category or the highest surface temperature must be specified by the operator while the safe temperature distances acc. to EN 13463-1 must be observed and the maximum temperature resistance of the coupling materials and seals are taken into consideration.

The marking of the temperature class must be effected readily visible by the operator.

The determination of the temperature class must be made acc. to the following table:

Max. temperature of fluids	Temperature class
75	T6
90	T5
130	T4
195	T3
295	T2
445	T1

The couplings are not admitted for the temperature classes T1 and T2 and may not be marked for that by the operator.

Installation instruction

6 Installation Instruction

6.1 General

Install the self sealing coupling into the network in due consideration of the general accident prevention regulations, so that:

- an error-free operation according to the operating instructions is guaranteed. Please make sure that you use only the hexagon on the connection which is provided by the customer to tighten or release the coupling / adaptor when assembling or dismantling it (see picture).

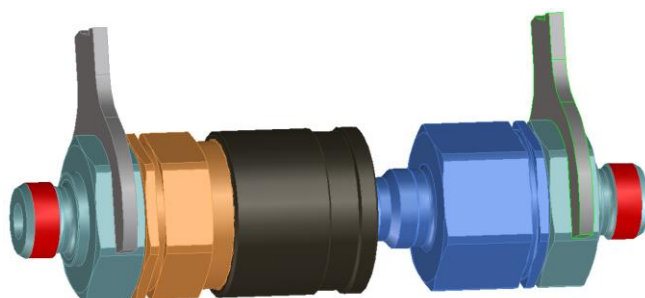
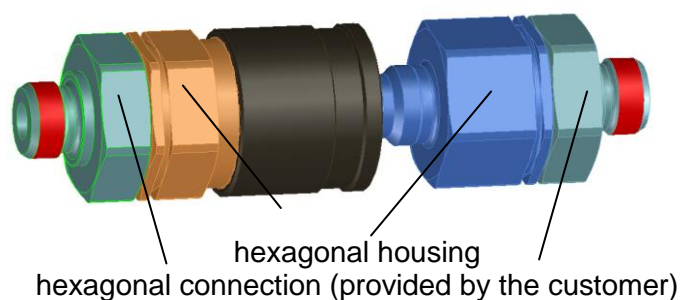

right

wrong

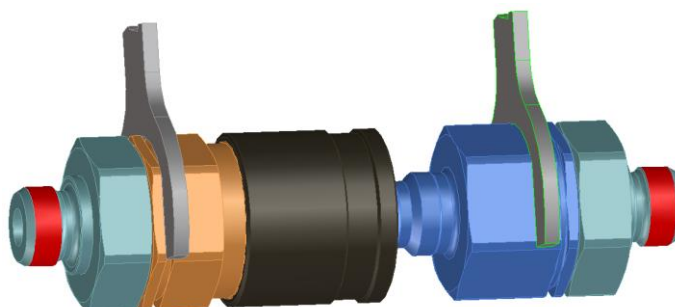

- the screw connection on the connection side (provided by the customer) is made according to the relevant technical regulations.
- the self sealing coupling is predominantly used on the network side and the self sealing coupling is mainly used on the consumer side.
- exterior damage to the unit and to all movable parts is ruled out.

Before installing the through type coupling and the adaptor to the piping system, make sure that the piping system has been sufficiently flushed/blown or cleaned.



After completing the installation work, perform a function test both depressurised and under working pressure, as described in the operating instructions.

Installation instruction

6.2 Extended installation instruction for application acc. to ATEX-guideline 94/9/EG

6.2.1 Details for safe operation

For the use of self sealing couplings as a hose connection it must be guaranteed that in case of pressure strikes the tumbling of the self sealing coupling can be avoided by fixing at suitable constructions. In principle it must be observed that the self sealing coupling cannot strike on hard objects which could produce strike sparks when touching the housing.

6.2.2 Details for safe installation

The self sealing couplings may only be connected to pipe- and hose systems which are suitable for electrostatic discharge and which are connected to the ground potential.

6.2.3 Details for a safe application area

The self sealing couplings may be used according to the class of devices² in areas susceptible to explosions where potentially explosive mixtures of gas, steam, mist and air are available.

Operating instruction

7 Operating Instruction

In order to avoid critical injuries of the staff and damage at the self sealing coupling during operation, coupling may be only used for the stated applications.

7.1 Connection process

Before every couple cycle a visual check of coupling and adaptor is to be carried out. In case of recognizable, visible damage or deformations damaged parts are to be exchanged.

Hold self sealing coupling firmly in one hand; with the other hand pull back locking sleeve. This has to be done against locking spring resistance.

Push free half (coupling) with withdrawn locking sleeve axially centered onto plug part of fixed half (adaptor) until sensible resistance.

Bring locking sleeve with support of locking spring into starting position.

Self sealing coupling and self sealing adaptor are now mechanically locked.

CAUTION



Please take care that locking sleeve is in final position, i.e. that it is flush in front with the coupling housing as otherwise no perfect lock is guaranteed.

7.2 Disconnection process

Withdraw locking sleeve against locking spring and take out coupling from self sealing adaptor.

Caution!

In case of an available pressure in the line connected by the coupling system a strong separation impulse - depending on the pressure - can be effective onto the coupling system during disconnection. For that reason the movable part of the coupling (free half) is to be firmly held in the hand to avoid injuries.

Operating instruction

7.3 Safety locking device SI (supplementary equipment)

7.3.1 Coupling process

For coupling the locking ring must be in unsecured position (picture 2).

Coupling as described under 7.1.

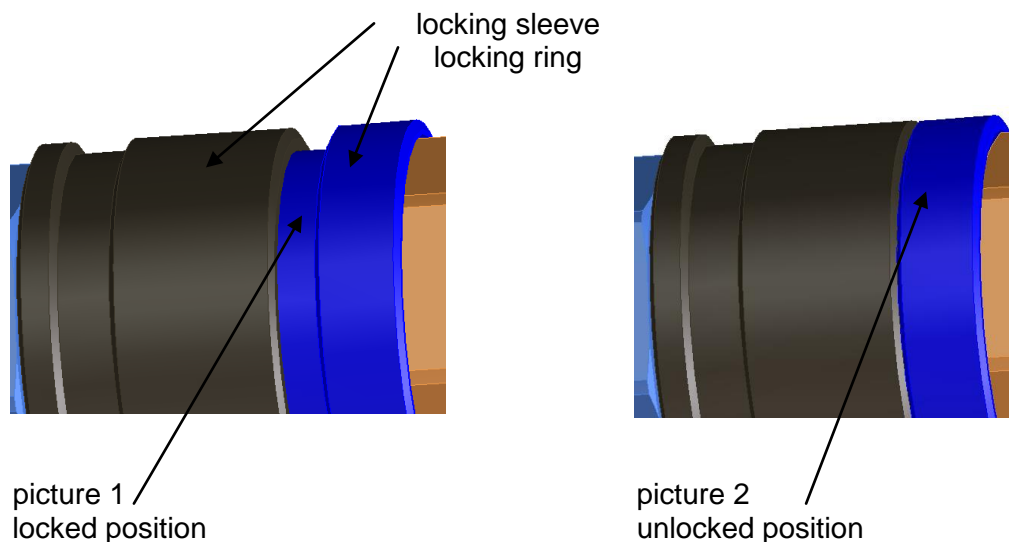

After coupling the locking ring is drawn towards the hose, turned by 90° and released. Now the locking ring snaps forward into the safety position (picture 1).

Both final positions – secured and unsecured – are fixed by spring loaded cams.

The operator can assure himself of the proper locking and saving by trying, as a control, to disconnect the coupling by drawing back the locking sleeve. This is not possible in secured position.

7.3.2 Decoupling process

In coupled situation the locking ring is in secured position (picture 1).

For de-blocking the locking ring is drawn towards the hose, turned by 90° and released.

Now the locking ring snaps forward into the safety position (picture 1).

Both final positions – secured and unsecured – are fixed by spring loaded cams.

Decoupling as described under 7.2.

Maintenance and Functional instruction

8 Maintenance Instruction

The WALTHER – coupling units are to be handled in such a way exterior damage to the elements as well as to all moving parts is prevented.

In order to minimise activation forces and to extend the lifetime of the coupling unit, we recommend lightly lubricating the connecting surfaces if this is permitted (see lubrication instructions).

In order to always ensure the functionality of the coupling unit and thus the protection of the operator, maintenance and functional testing must be carried out independantly of the operating instructions and at a suitable interval.

Note!

In the event of maintenance that is carried out by neither WALTHER-PRÄZISION nor by personnel trained by WALTHER-PRÄZISION, the warranty of WALTHER-PRÄZISION is voided. This does not apply when maintenance is carried out by personnel trained by WALTHER-PRÄZISION.

Note!

In the event of media that is hazardous to health a coupling unit returned to WALTHER-PRÄZISION must be sent in a fully cleaned state. No media hazardous to health may be released from the coupling unit during the dismantling process. The sending party (customer) is responsible for this.

8.1 Maintenance:

- With the coupling unit in the decoupled state, carry out an external visual check for damages and contamination.
- Contamination in the functional area that can be accessed from the outside (seal region, activation elements) must be removed by wiping.

In the event of damaged, cracked or corroded parts, the coupling unit must be removed and sent to WALTHER-PRÄZISION for repair (see Note).

In the event of worn, brittle or overaged seals as well as serious contamination, it is the decision of the customer whether they wish to send the coupling unit WALTHER-PRÄZISION or whether they wish to repair it themselves (see Note).

Maintenance and Functional instruction

8.2 Functional testing:

As described in the operating instructions, the coupling unit is coupled, pressure is applied and it is decoupled and this process is carried out multiple times.

In doing so, the following should be taken into consideration:

- Proper, easy functionality when coupling and decoupling.
- Sealing of the coupling unit in the coupled and decoupled state.

In the event of damaged, cracked or corroded parts, the coupling unit must be removed and sent to WALTHER-PRÄZISION for repair (see Note).

In the event of worn, brittle or overaged seals as well as serious contamination, it is the decision of the customer whether they wish to send the coupling unit to WALTHER-PRÄZISION or whether they wish to repair it themselves (see Note).

Note!

**When repairing, a pressure and sealing test must always be carried out.
This may also be completed by means of the working process.
The procedure and scope of this test is described in the "Test" section.**

9 Test

For applications up to 2 bar, WALTHER-PRÄZISION recommends a leakage test by immersion trial. For applications above 2 bar, it is up to the user, if a leakage test by immersion trial or a pressure test by test bench has to take place.

9.1 Immersion test

9.1.1 Test setup of the connected state (schematic view)

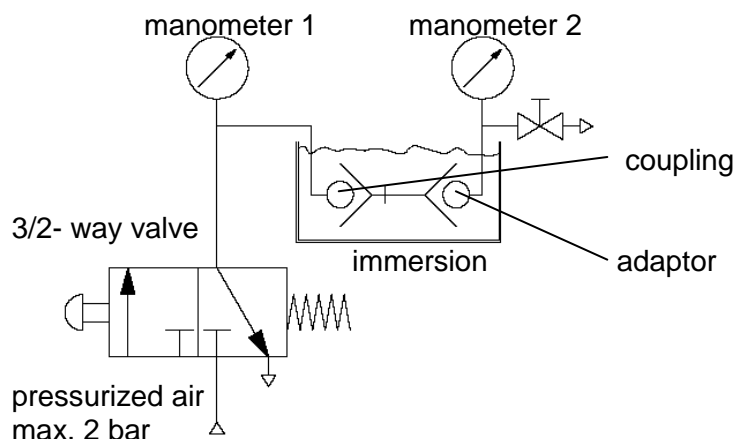

9.1.2 Test procedure

- Prepare test setup
- 3/2-way valve is operated by sensing device and held up during the test.
- Valve is impinged with max. 2 bar pressurized air, both manometers show the same existing pressure.
- The holding time of the test is 10 seconds.
- To stop testing, release the sensing device at the 3/2-way valve. Through the preload, the 3/2-way valve runs back to the starting position.
- The medium in the test setup (pressurized air) escapes through the 3/2-way valve. Both manometers must show **0 bar** now.

Attention

**If this does not happen, the test is not carried out correctly.
It is not allowed to disconnect now.**

- By opening the stopcock at manometer 2, the remaining pressure can be reduced now.
- As soon as both manometers show 0 bar, disconnecting and dismantling of the test setup is permitted.
- After successful failure detection and elimination, the test has to be repeated correctly.
- After the test, the valve has to be dried as soon as possible in warm air (recommendation: 45 – 55 °C, approx. 30 min. in air stream, up to 2 hours in stagnant air, depending on the device).

9.1.3 Test disconnected

Test setup and procedure are identical for both coupling and adaptor.

9.1.4 Test setup of the disconnected state (schematic view)

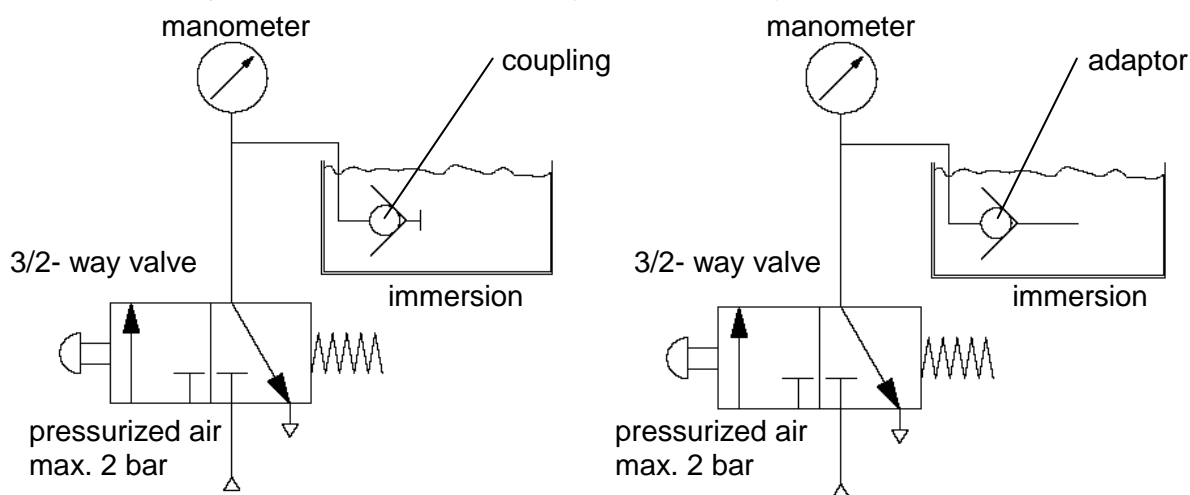

9.1.5 Test procedure

- Prepare test setup
- 3/2-way valve is operated by sensing device and held up during the test.
- Valve is impinged with max. 2 bar pressurized air, both manometers show the same existing pressure.
- The holding time of the test is 10 seconds.
- To stop testing, release the sensing device at the 3/2-way valve. Through the preload, the 3/2-way valve runs back to the starting position.
- The medium in the test setup (pressurized air) escapes through the 3/2-way valve. After correct test setup, the manometer will show **0 bar** again.
- Dismantling of the test setup is permitted now.
- After the test, the valve has to be dried as soon as possible in warm air (recommendation: 45 – 55 °C, approx. 30 min. in air stream, up to 2 hours in stagnant air, depending on the device).

9.1.6 Test result

During the holding time of 10 seconds, bubbling shall not occur neither in connected, nor in disconnected state. If bubbling occurs in these 10 seconds, the valve has to be considered leaking and is not permitted for use. Failure detection and elimination has to be carried out as well as a new test.

9.2 Pressure test

9.2.1 Test setup of connected state (schematic view)

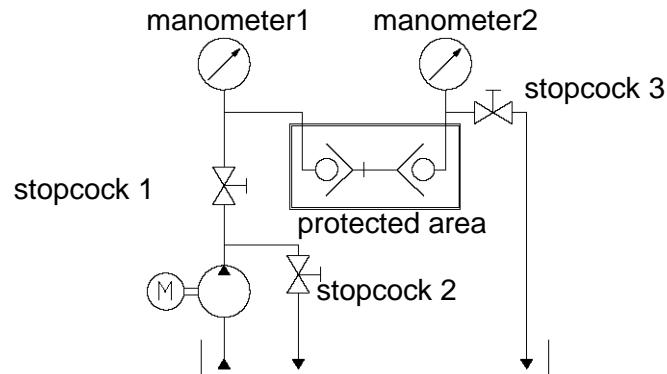

9.2.2 Test procedure

- Prepare test setup.
- The test setup must be laid out in accordance to relevant safety regulations, e. g. industrial safety regulations etc. and to the required pressure. The container (protected area) in which the valve is laid during the test, must be laid out so that neither escaping media under pressure nor parts of the test piece can endanger the operator (e. g. bursting).
- Test media is water or oil, according to the material of the valve which has to be tested. The sealing material EPDM shall not be tested with oil.
- The user of the test setup is required to plan and control the implementation of appropriate measures to ensure a safe operation.
- At the beginning of the test, stopcock 1 is open, stopcocks 2 and 3 are closed.
- Before the pressure test, it has to be ensured that no gaseous/compressed media is left in the valve.
- For this purpose, the valve has to be vented before pressurization. Open stopcocks 1 and 3 and lead the test media through the test piece until there is no more gaseous media left.
- Switch off pump and close stopcock 3.
- Slowly apply pressure to the valve. Pressure test is 1,3 x working pressure. (working pressure, please see product description).
- Both manometers show test pressure.
- Close stopcock 1; test pressure is locked within the valve for 5 min.
- Switch off pump and open stopcock 2.
- To finish testing, open stopcock 1 and the test media will flow back into the container.
- Both manometers must show **0 bar** now.

Attention

If this is not happened, the test is not carried out correctly.

Disconnecting is not permitted now.

- By opening stopcock 3, the residual pressure can escape.
- If both manometers show 0 bar, disconnecting and dismantling of the test setup is permitted.

- After successful failure detection and elimination, the test has to be repeated correctly.
- After the test, the valve has to be dried as soon as possible in warm air (recommendation: 45 – 55 °C, approx. 30 min. in air stream, up to 2 hours in stagnant air, depending on the device).

9.2.3 Test disconnected

Test setup and test procedure are identical for both coupling and adaptor.

9.2.4 Test setup of the disconnected state (schematic view)

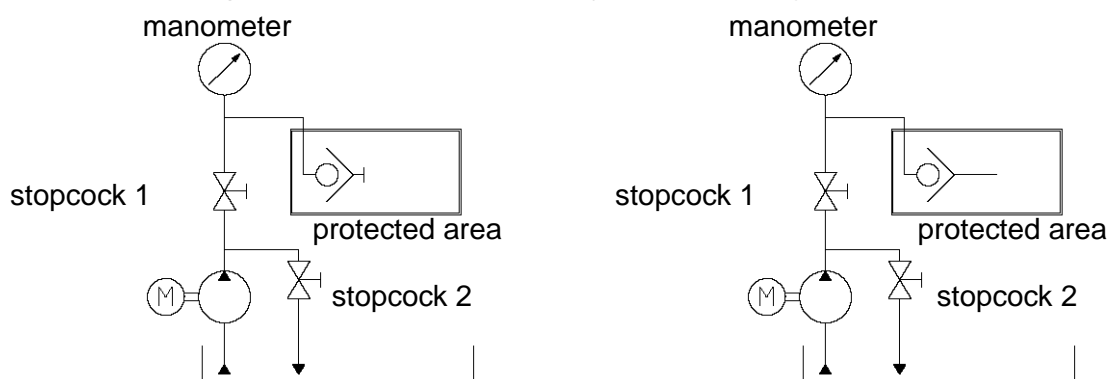

9.2.5 Test procedure

- Prepare test setup.
- The test setup must be laid out in accordance to relevant safety regulations, e. g. industrial safety regulations etc. and to the required pressure. The container (protected area) in which the valve is laid during the test, must be laid out so that neither escaping media under pressure nor parts of the test piece can endanger the operator (e. g. bursting).
- Test media is water or oil, according to the material of the valve which has to be tested. The sealing material EPDM shall not be tested with oil.
- The user of the test setup is required to plan and control the implementation of appropriate measures to ensure a safe operation.
- Before the pressure test, it has to be ensured that no gaseous/compressed media is left in the valve.
- For this purpose, the valve has to be vented before pressurization. This is only possible in coupled state. Open Stopcocks 1 and 3 (see test in coupled state) and lead test media through test piece until there is no more gaseous media left.
- Switch off the pump, disconnect the unit and slowly pressurize the respective side (coupling or adaptor). Test pressure is 1,3 x working pressure (working pressure see product description).
- Manometer shows test pressure.
- Close stopcock 1; test pressure is locked within the valve for 5 min.
- Switch off pump and open stopcock 2.

- To finish testing, open stopcock 1 and the test media will flow back into the container. The manometer must show **0 bar** after correct test setup.
- The test setup can be dismantled.
- After the test, the valve has to be dried as soon as possible in warm air (recommendation: 45 – 55 °C, approx. 30 min. in air stream, up to 2 hours in stagnant air, depending on the device).

9.2.6 Test result

After 5 min. of testing, the pressure decrease must not exceed 5 % in connected and disconnected state with a test pressure up to 700 bar.

With a test pressure of more than 700 bar, the pressure decrease must not exceed 3 %. If the pressure loss is higher or if media escapes obviously, the valve is to be considered leaking and is not permitted for use.

Failure detection and elimination as well as a new test are required.

9.3 Documentation

Tests have to be documented with registration of test pressure, test media, name/date and signature.

10 Lubrication !

In order to minimize the activation forces and to extend the lifetime of the coupling, we recommend cleaning and lightly greasing the connecting surfaces at suitable intervals as long as there is no risk that contamination in the vicinity will cause increased wear in combination with grease.

Lubrication is not carried out if the application does not permit it (e.g. in medical technology).

The selection of the lubrication is determined by the operator of the coupling and their purchasing options.

The connecting surfaces may only be lubricated if the operating conditions permit it.

Thus:

- The lubrication must be selected in accordance with compatibility with the seal quality and material.
- Media/lubrication combinations in which the lubrication properties are changed (e.g. turns to resin) must be avoided.
- Media/lubrication combinations that prevent safe operating conditions (e.g. lubrication/oxygen) must be avoided.

The lubrication interval depends on the framework conditions and the use of the application and is determined by the operator.

11 Storage

The coupling must be stored in a way that it cannot be damaged.

To avoid damage or dirt the transportation covers must be attached on all connections.

The storage conditions of the coupling depend on the guidelines applicable to the gaskets, since improper storage can lead to deterioration of the gaskets.

The following points must be observed:

- The gaskets must be stored dry.
- For the preservation of the gaskets, the gaskets should not be stored where they are exposed to the effects of daylight.
- For protection against oxygen, the gaskets should be stored in the original packaging.

12 Shut-down

At the end of the service life the coupling or its components have to be disposed non-polluting and according to the legal regulations.

For that the local public or private disposal societies should be taken.