

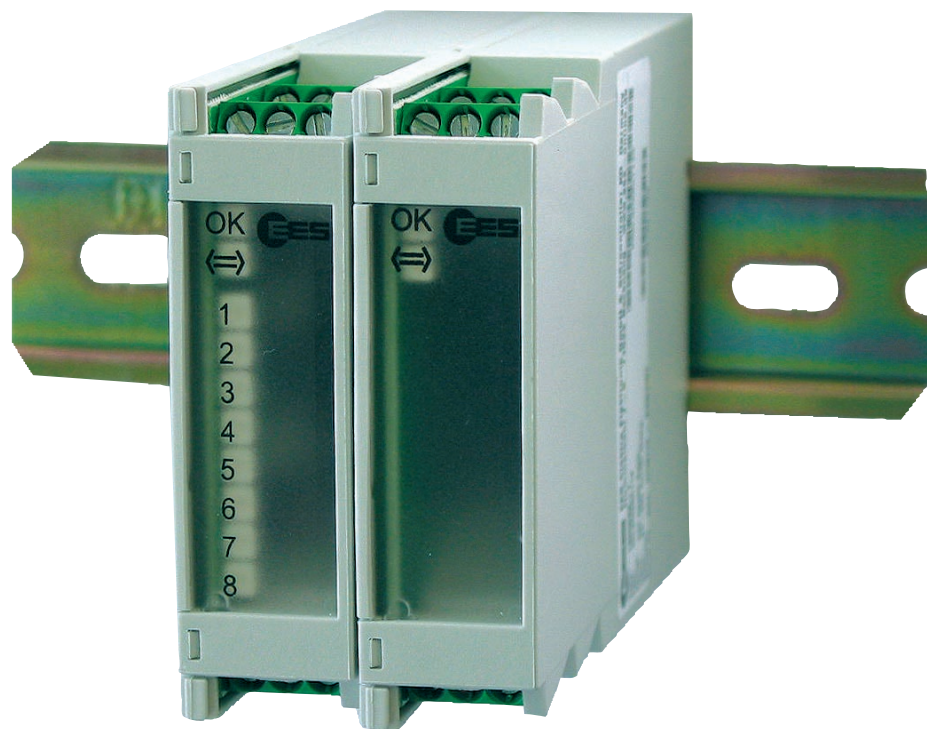

# ZS8A

## 2-wire telecontrol system



### → Unidirectional transmission on control lines up to 15 km distance

- › Transmission of 8 binary values, two of it are configurable as counting values
- › Expansion possibilities by 8 additional binary values or one analog value
- › Short-circuit proof transistor outputs
- › High interference immunity of the transmission; adjustable data rate
- › The state of the outputs are adjustable on transmission errors
- › Easy configuration by DIP-switches
- › Operation monitoring and status indication by LED
- › Compact, 22,5mm wide modules for DIN-rail assembly

➔ **Mode of operation 2-wire transmission**

The two-wire transmission system ZS8A was especially designed for cable-saving and immune to disturbance transmission of messages, commands and analog values over control lines with up to 15 km distance.

The ZS8A system has no certain demand on the quality of the used cable for transmission, it has a high disturbance immunity against couplings from supply or signalling lines run in parallel. Therefore it is suitable for signal transmission in branched water / wastewater plants, industrial facilities and railway plants as well as building automation.

➔ **System extension**

The basic extension of a ZS8A-system consists of a transmitter basic module and a receiver basic module. This enables unidirectional transmission of 8 messages, from it up to 2 counting values. On request the basic modules can be extended by an expansion module of 8 additional digital inputs or by an analog expansion module for one analog input. The connection between basic module and expansion module is done by the supplied system cable and the RJ45 jacks on the bottom side of the modules. In the module front plate LED's are monitoring the status of the messages and also operation indication of the system.

Possible ZS8A-Extension variants

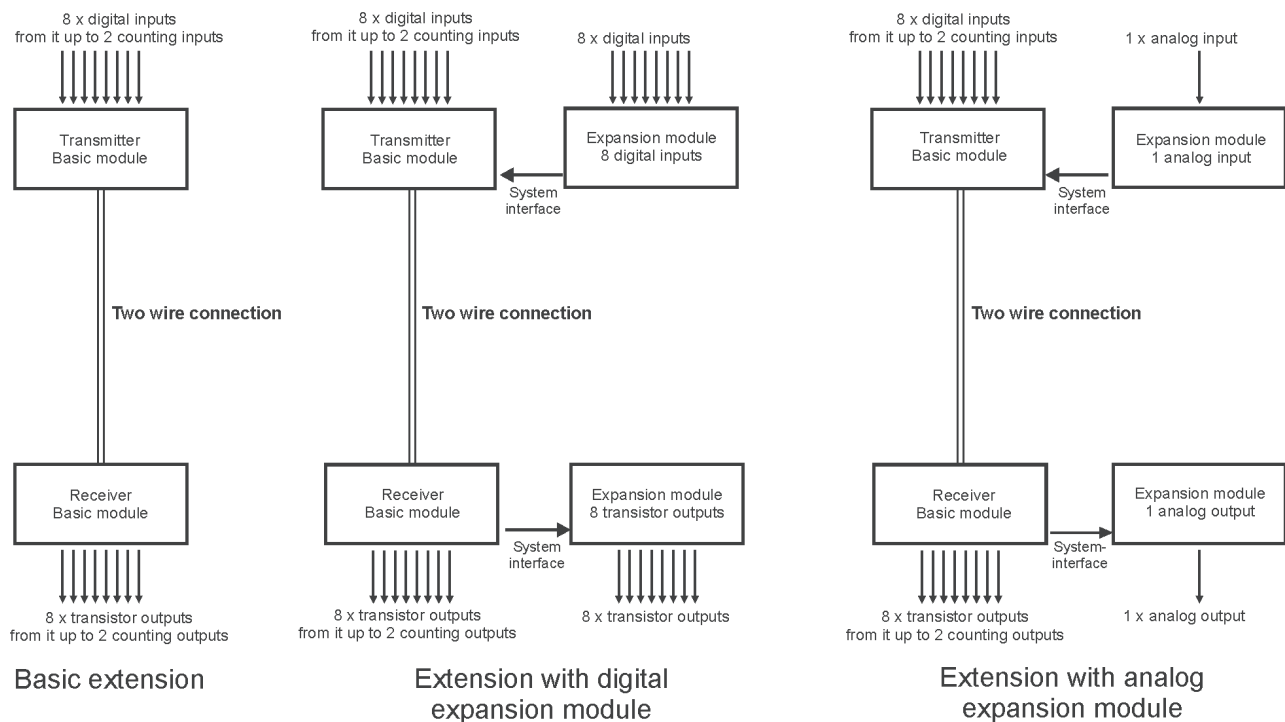

➔ **In- and outputs**

The in-/outputs E1 and E2 and respectively A1 and A2 of the basic module can be switched over between the functional type of static or counting-/momentary pulses. The binary outputs are designed with short-circuit proof plus switching PNP-transistors and free-wheeling diodes, so that bulbs, magnetic valves or contactors can be controlled directly.

In- or output of the analog expansion module can process a current signal (0 ... 20 mA) or a voltage signal (0 ... 10 V).

On disturbance of the transmission the digital outputs are set on dependent on the configuration of the receiver basic module. "last known valid state" or "all outputs set to 0".

At the analog output there is always the value of the last valid transmission present.



## → Mode of operation 2-wire transmission

Every usual signal cable is suitable as transmission wire, in which the maximum loop resistance must not be exceeded. The bridgeable distance depends on the quality of the cable and the form and quantity of possibly noise interferences.

To adapt the ZS8A on the different application cases ( type of transmission cable, distance of transmission and the speed requirements for transmission ), the data transmission rate is adjustable by DIP-switches. With lower baud rates larger distances and higher immunity against disturbances can be achieved.

The data transmission of the ZS8A is done by digital telegrams coded with a checksum. The receiver module can safely recognize disturbed, faulty telegrams and also reject them. Possible disturbances result in a delayed transmission or interruption of the connection, but do not lead to falsified output values.

The ZS8A always transmits the actual state of the inputs at the time of inquiry. The minimum pulse width / pause, which is needed for a safe transmission of a change of state, depends on the actual set transmission baud rate (see table). For transmission of short pulses the inputs E1 and E2 and referring outputs A1 and A2 of the basic modules can be used for safe counting value transmission. Counting values are summed at the transmitter module until the next inquiry and transmitted as counter reading. The receiver module issues the difference of successive received counter readings in form of a pulse sequence, so that no counting pulses can be lost.

Duration of a transmission cycle in dependence of the set baud rate				
Baud rate [Baud]	1200	2400	4800	9600
Distance of two telegrams [ms] (Transmission cycle)	120	60	30	15
Minimum pulsewidth /-pause [ms] for the transmission of binary values	120	60	50	50

**Note:**

The ZS8A-series is a further development of the approved previous ZS8-system. Both systems have identical terminal assignments and similar dimensions. However existing ZS8-modules can not be replaced through ZS8A-modules or be combined with them.

➔ Block diagram of the ZS8A-modules

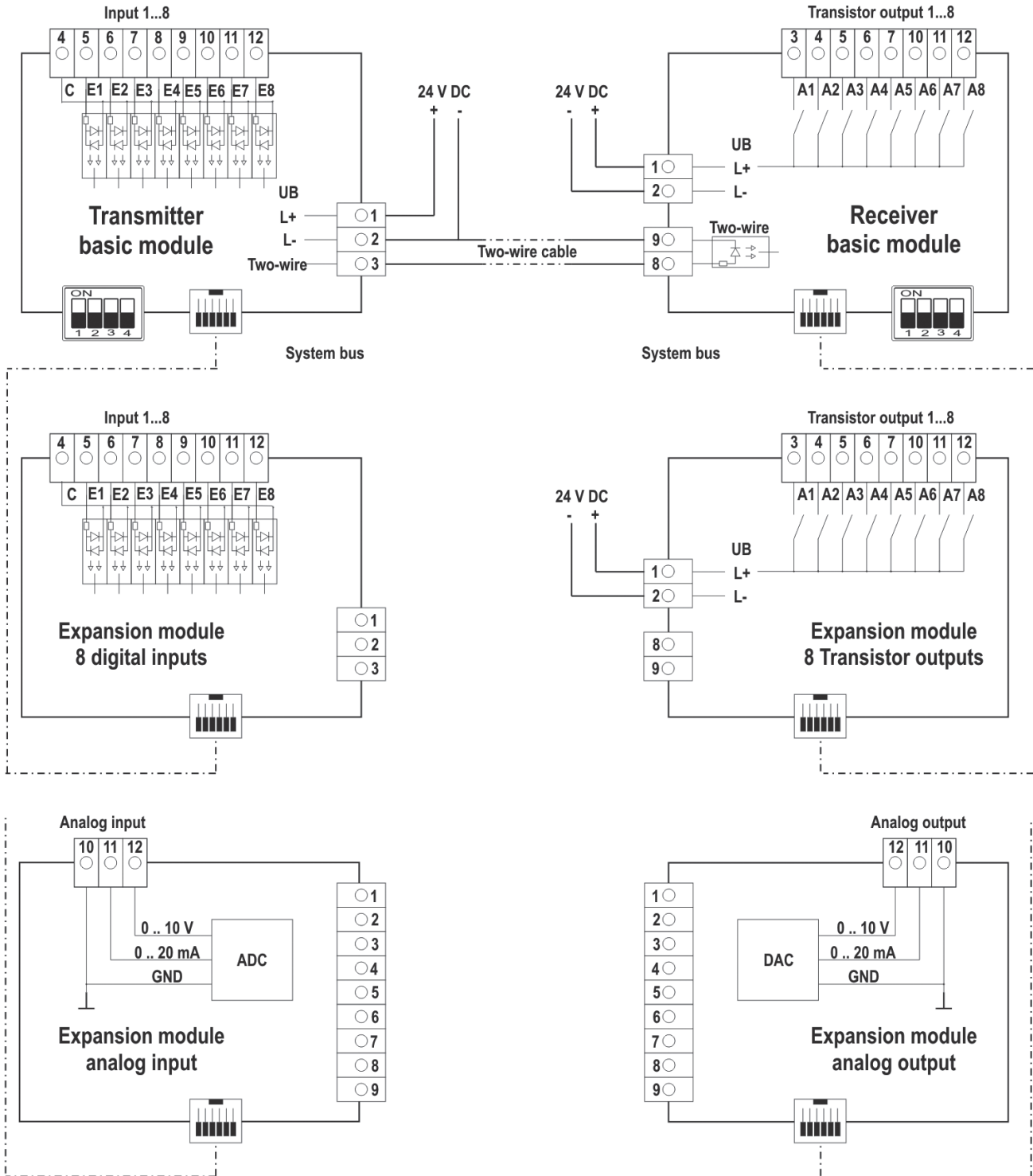



→ Terminal assignment

Top view

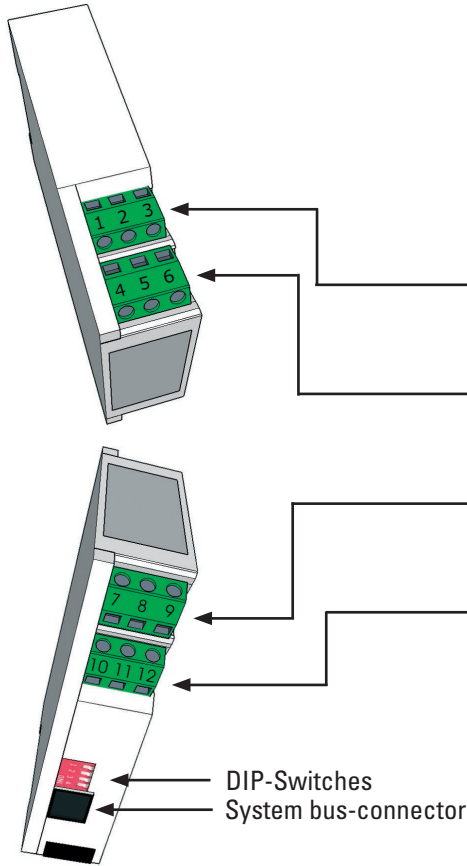

Terminal	ZS8A-					
	GS8DE	GS8DA	EMG8DE	EMG8DA	EM1AE	EM1AA
1	L+	L+		L+		
2	L-	L-		L-		
3	2-wire	A1		A1		
4	C	A2	C	A2		
5	E1	A3	E1	A3		
6	E2	A4	E2	A4		
7	E3	A5	E3	A5		
8	E4	2-wire	E4			
9	E5	2-wire	E5			
10	E6	A6	E6	A6	GND	GND
11	E7	A7	E7	A7	0 ... 20 mA	0 ... 20 mA
12	E8	A8	E8	A8	0 ... 10 V	0 ... 10 V

Bottom view

→ Dimensions

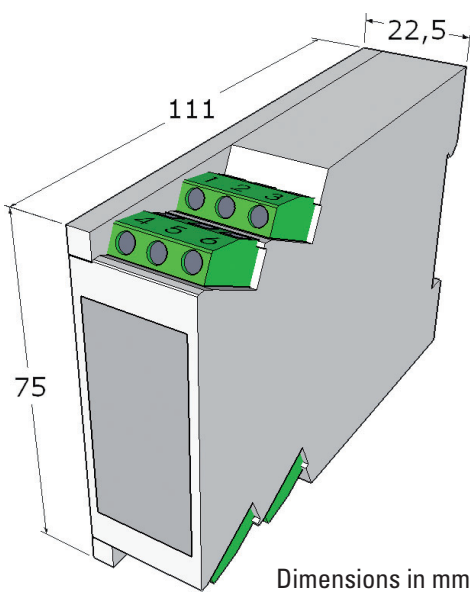

Dimensions are valid for all ZS8A-modules

→ **Technical data**

Nominal operating voltage $U_B$	24 V DC	
Operating voltage range	20 ... 32 V DC	
Power consumption at $U_B$	24 V DC	32 V DC
Transmitter basic module	max. 1,0 W	max. 1,3 W
Expansion module digital input	max. 0,4 W	max. 0,4 W
Expansion module analog input	max. 0,3 W	max. 0,4 W
Receiver basic module	max. 1,4 W	max. 2,3 W + load current
Expansion module digital output	max. 1,4 W	max. 2,3 W + load current
Expansion module analog output	max. 0,4 W	max. 0,5 W

**Digital inputs**

Input voltage	16 ... 35 V DC*
Input resistance	approx. 10 k $\Omega$
min. pulse width-/pause	50 ms
max. count rate (basic module E1/E2)	10 Hz

**Transistor outputs**

Load on Transistor outputs	max. 500 mA
Total current of all outputs	max. 1,6 A
Pulse width -/pause (basic module A1/A2)	40 ms or 500 ms adjustable
Counting rate (basic module A1/A2)	12,5 Hz or 1 Hz adjustable

**Analog I/O**

Resolution	8 Bit
Accuracy of the analog value	Input signal $\pm$ 2 % of the scale
Voltage signal	0 ... 10 V
Input resistance	100 k $\Omega$
Minimum load resistance (output)	1 k $\Omega$
Current signal	0 ... 20 mA
Current input burden	100 $\Omega$
Maximum output burden	500 $\Omega$

**Galvanic isolation**

Insulation voltage (effective):	
Transmitter: Digital inputs against supply circuit	2,5 kV DC
Receiver: 2-wire against supply circuit	2,5 kV DC

**EM Compatibility**

Interference immunity	DIN EN 61000-4-2:2001-12
	DIN EN 61000-4-3:2008-06
	DIN EN 61000-4-4:2005-07
	DIN EN 61000-4-5:2007-06
	DIN EN 61000-4-6:2008-04
	DIN EN 61000-4-12:2007-08
Noise radiation	DIN EN 61000-3-3:2006-06
	DIN EN 55011:2007-11

**Signal transmission**

Two-wire level	maximum $U_B$ / 25 mA
Loop resistance	maximum 10 k $\Omega$
Transmission rate (adjustable)	1200, 2400, 4800 or 9600 Baud



**Signal transmission**

Two-wire level	maximum $U_b$ / 25 mA
Loop resistance	maximum 10 k $\Omega$
Transmission rate (adjustable)	1200, 2400, 4800 or 9600 Baud

**General data**

Operating- and ambient temperature	-20°C ... + 60°C without condensation
Storage temperature	-20°C ... + 70°C without condensation
Permitted relative humidity	max. 75 % annual average (Gr. F DIN 40040)
Connection terminals	Screw terminals, nominal cross section 1,5 mm <sup>2</sup>
Housing / Protection	Plastic / IP 40
Assembly	DIN mounting rail TS35 acc. to DIN EN 60715:2001-09
Weight	
ZS8A-GS8DE / ZS8A-EM8DE	approx. 110 g
ZS8A-GE8DA / ZS8A-EM8DA	approx. 100 g
ZS8A-EM1AE / ZS8A-EM1AA	approx. 90 g

\*Other values on request

Subject to changes without prior notice !

The information are referring to an ambient temperature of 25°C, otherwise noted.

**→ Order identification**

Item number	Type	Short description
92ZS8AGS8DE	ZS8A-GS8DE	Transmitter basic module with 8 digital inputs 24 V DC
92ZS8AGE8DA	ZS8A-GE8DA	Receiver basic module with 8 transistor outputs 24 V DC
92ZS8AEM8DE	ZS8A-EM8DE	Expansion module 8 digital inputs 24 V DC
92ZS8AEM8DA	ZS8A-EM8DA	Expansion module 8 transistor outputs 24 V DC
92ZS8AEM1AE	ZS8A-EM1AE	Expansion module analog input 0 ... 20 mA or 0 ... 10 V
92ZS8AEM1AA	ZS8A-EM1AA	Expansion module analog output 0 ... 20 mA or 0 ... 10 V

The system cable for connecting basic- and expansion module is included in the scope of supply of the expansion modules.

**→ Do you have increased requirements ?**

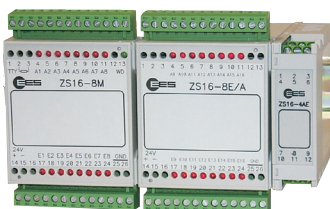

**ZS 16 - Micro telecontrol system**

- Bi-directional two-wire transmission on up to 15 km control lines
- Modular system configuration up to 16 binary and 4 analogue values in both directions
- Short-circuit proof transistor outputs, adjustable intrinsically safety status
- Operation supervision with LED and fault contact

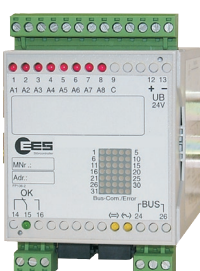

**MFW - Modular two-wire telecontrol system:**

- Telecontrolling on potential free wires up to 30 km distance
- Modular extension up to 32 RTU's and a maximum of 512 I/O-Modules
- Easiest parameterisation of the modules by use of DIP-switches
- High immunity against disturbances due to carrier frequency sequence, Hamming distance > 6
- Easy coupling to third party systems (e.g. PC, PLC or process control system) with different interfaces and protocols.  
(e.g. 3964R/RK512, Modbus-RTU, Modbus-TCP, Profibus-DP, IEC 60870-5-101 oder -104)

→ You will find a suitable power supply within our accessories portfolio.



## Power supplies

### WSN 0,9/24 Wide range switching power supply

- Compact 22,5 mm thin power supply
- Input voltage range nominal 100 ... 240 V AC  
110 ... 220 V DC
- Output voltage 24 V DC
- Rated output current 0,9 A

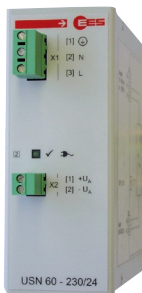

### WSN 60 Wide range switching power supply

- Input voltage range nominal 90 ... 264 V AC
- Output voltage 24 V DC
- Rated output current 2,5 A



## Uninterruptible power supplies

### CBS - Capacitor Backed 24 V power supply

- Broad input voltage 115 ... 230 V AC
- Nominal output current 2 A
- High life time: 30 years @ 30° Celsius
- Maintenance-free by long-lasting ultra capacitors
- Energy storage for 500 or 1000 J

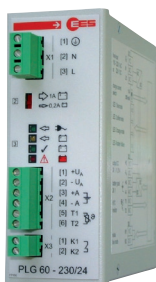

### PLG 60 - Accumulator buffered 24 V power supply

- Input voltage range 90 ... 264 V AC  
127 ... 370 V DC
- Output nominal current 1,25 A
- Usable for lead and gel accumulators with capacities of 1.2 Ah up to 38 Ah
- High efficiency by microcontroller supported loading and discharging of the accumulator
- Higher accumulator life time by an optional temperature sensor