



Adjustable Dead Band Pressure Detectors

Form 281

The adjustable dead band pressure detector should be used when there is a requirement for an adjustable and wide dead band between the increasing and decreasing set points.



**V3 Weathertight Explosion Proof
Hermetically Sealed Detectors**

Function

Alarm: Hi – Lo
Control: On – Off



V1 Weathertight Housing

*Design and specifications are
subject to change without notice.
For latest revision, see www.sorinc.net.*

Features and Benefits

- 3-year warranty from date of manufacture
- **Safety Certified to IEC 61508 (SIL)** SOR products are certified to IEC 61508 for non-redundant use in SIL1 and SIL2 Safety Instrumented Systems for most models. For more details or values applicable to a specific product, see the Safety Integrity Level Quick Guide (Form 1528).
- Wide adjustable dead band
- Independent adjustments for increasing and decreasing Set Points
- Field adjustable with fine resolution of Set Points
- Instrument quality – high repeatability
- High overrange and proof pressures
- Exceptionally long life
- Not critical to vibration
- Wide selection of wetted parts materials for process compatibility and containment

Adjustable Dead Band Pressure Detectors

Principle

The SOR Adjustable Dead Band pressure detector incorporates two industry proven Static "O" Ring pressure sensing elements. Media pressure on the areas of the pistons counteracts the forces of the range springs – each adjustable by a separate adjusting nut – and moves the piston shafts to operate the lever assembly which, in turn, actuates and deactuates the electrical detecting element. Each pressure sensing element of the Adjustable Dead Band pressure detector is a force balance piston-actuated assembly sealed by a flexible diaphragm and an o-ring that is static. The only wetted parts are the single pressure port, two diaphragms, and two o-rings all indicated with asterisks (*) in this illustration.

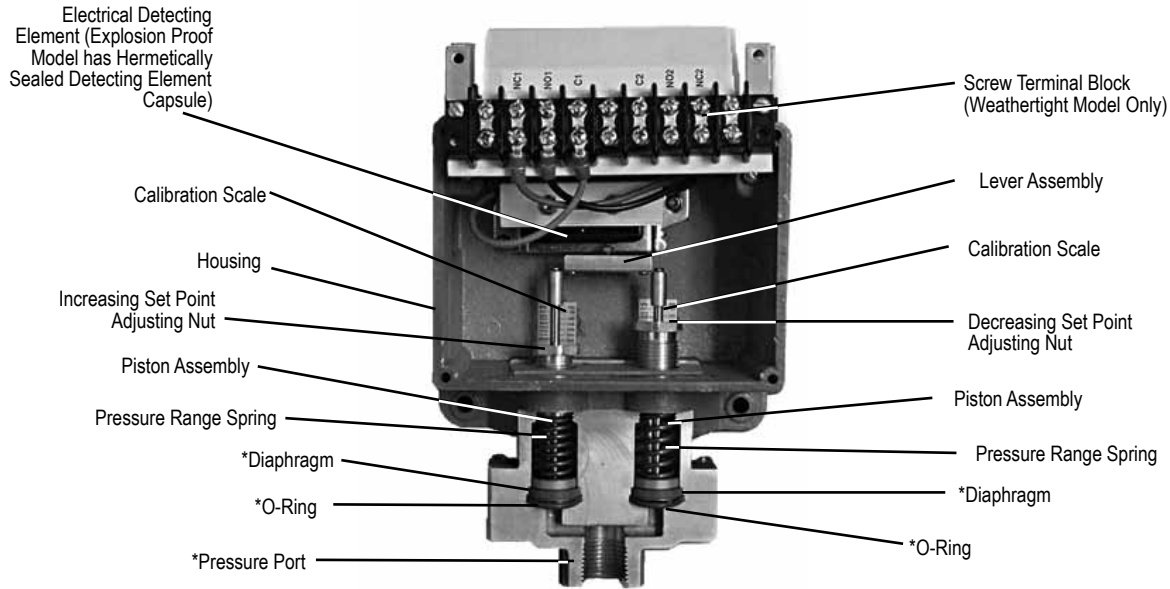

Principle Schematic

The lever assembly travel illustrated here has been exaggerated for clarity.

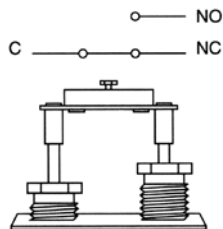

No Pressure: Electrical detecting element is deactuated.

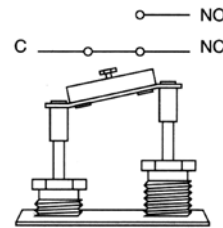

Pressure greater than decreasing Set Point but less than increasing Set Point. Electrical detecting element remains deactuated.

Actuation

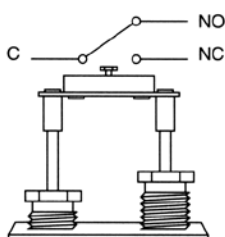

Pressure equal to or greater than increasing Set Point: Electrical detecting element is actuated.

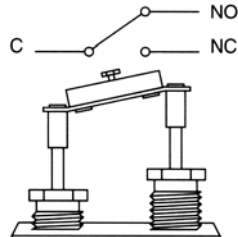

Pressure less than increasing Set Point but greater than decreasing Set Point: Electrical detecting element remains actuated.

Deactuation

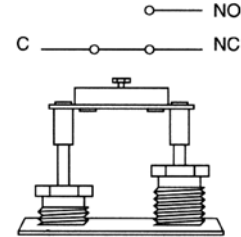

Pressure equal to or less than decreasing Set Point: Electrical detecting element is deactuated.

Model Number System

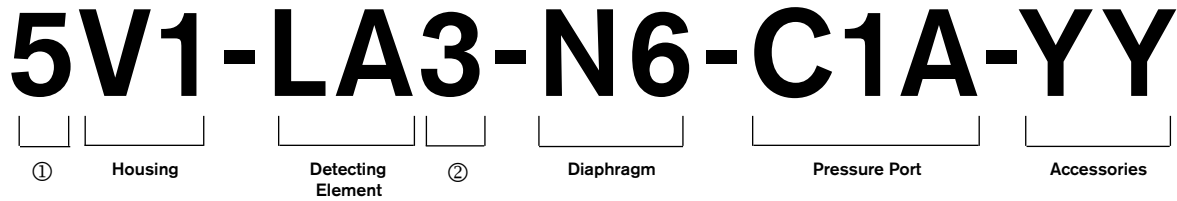

How to Order

Information and data in this catalog are formatted to provide a convenient guide to assist instrument engineers, plant engineers and end users in selecting pressure detectors for their unique applications.

Steps 1 through 5 are required. Step 6 is optional. Orders must have complete model numbers, i.e. each component must have a designator.

Step 1: Select **Adjustable Range** from pages 4, 5 and 6 to fill in ① and ②.

Step 2: Select **Housing**. Weathertight or explosion proof/weathertight (page 6).

Step 3: Select electrical **Detecting Element** for electrical service (page 7).

Step 4: Select **Diaphragm and O-Ring** for process compatibility and containment (page 8).

Step 5: Select **Pressure Port** for process compatibility and connection (page 9).

Step 6: Select **Accessories** required for service (page 9).

If Agency Approved, Certified or Listed pressure detectors are required, see page 10 for components that must be specified.

Adjustable Dead Band Pressure Detectors

Step 1: Adjustable Range

5V1-LA3-N6-C1A-YY

Six adjustable dead band ranges are available. Each adjustable range is displayed on a grid (pages 5 and 6). Determine the correct adjustable range for the application by checking increasing and decreasing Set Point requirements against the tables. In the example below, a contact closure is required when pressure increases to 160 psi. The same contact must open when pressure decreases to 60 psi. Since 60 psi is within the blue field, the example grid range is correct for the application.

When the correct range grid is selected, insert range designators ① and ② from that grid into the model number.

Step 1

Find the specified increasing Set Point at the top of the graph.

Step 2

Find the specified decreasing Set Point along the left edge of the graph.

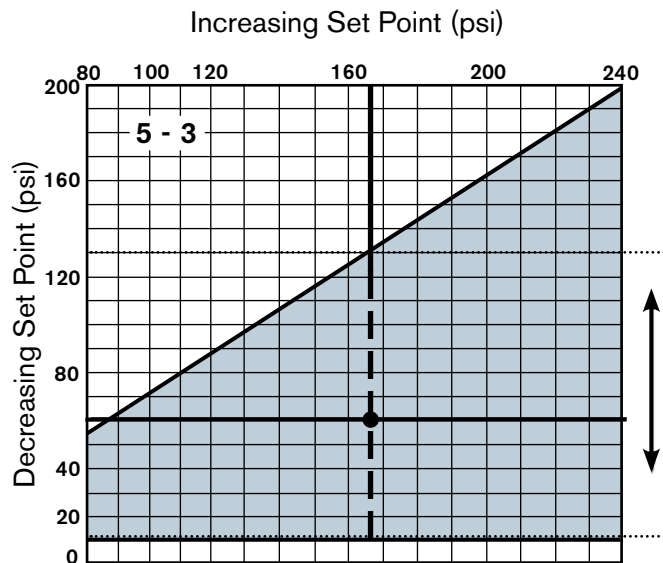

Step 3

Following the vertical line down from the increasing Set Point. Follow the horizontal line across from the decreasing Set Point. Any point within the blue field is acceptable.

① 5 ② 3

5V1-LA3-N6-C1A-YY

1st and 4th places in model number

Adjustable Dead Band Pressure Detectors

Step 1: Adjustable Range

5V1-LA3-N6-C1A-YY

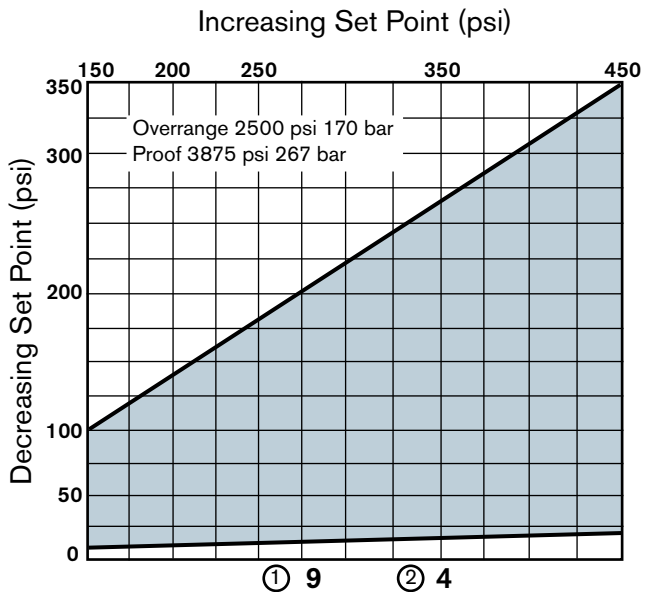
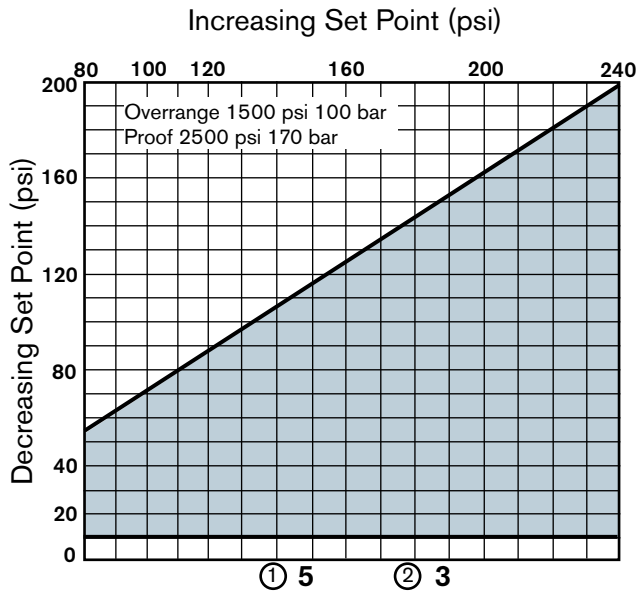
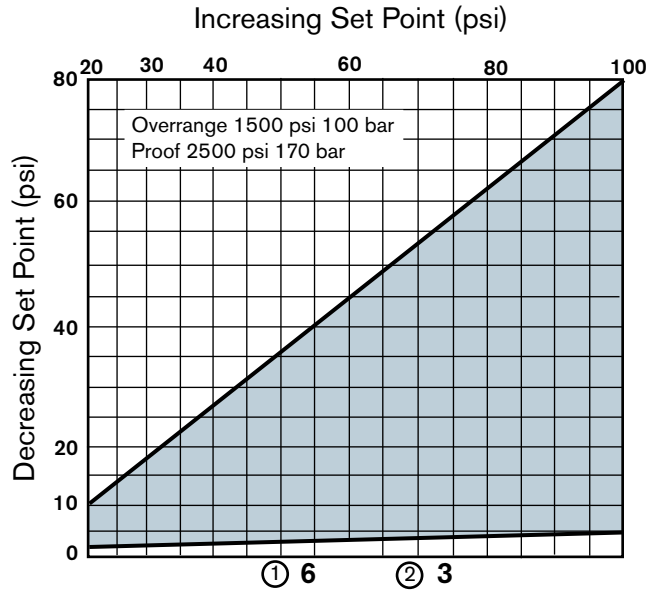
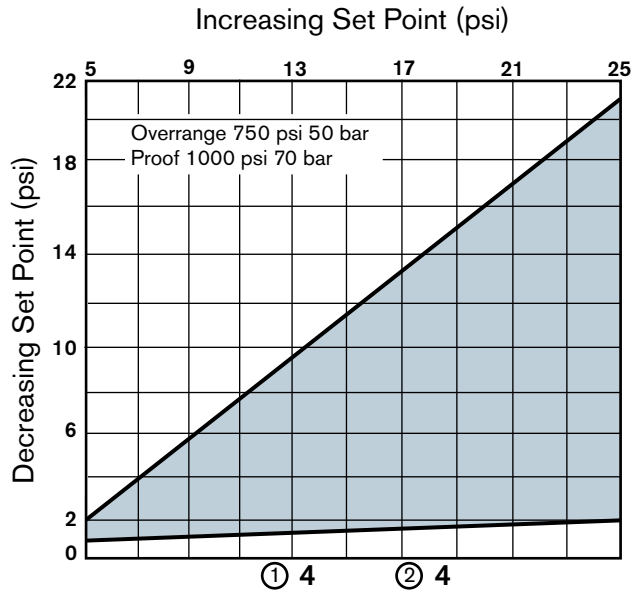

Adjustable Dead Band Pressure Detectors

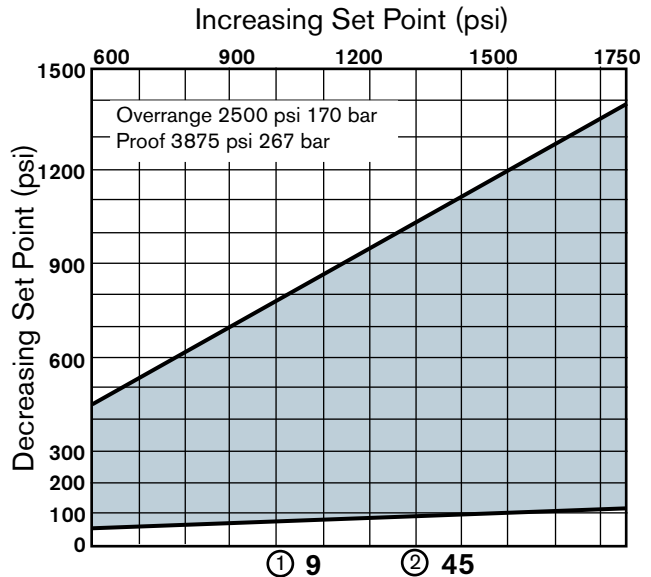
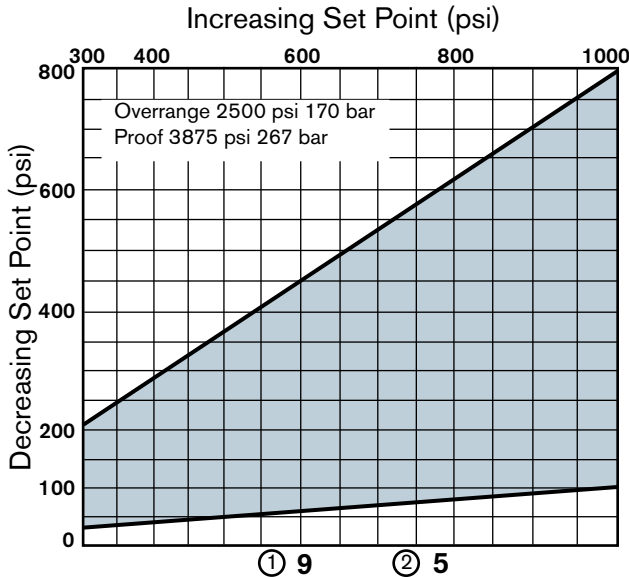

Step 1: Adjustable Range

5V1-LA3-N6-C1A-YY



Step 2: Housing

5V1-LA3-N6-C1A-YY

Service	Description	Designator
Non-Hazardous Locations	<p>Weathertight for non-hazardous service. NEMA 4, 4X & IP65 Electrical conduit connection: 3/4" NPT(F) Material: 356 aluminum Use LA or SA detecting element and terminal block. Shipping weight: 4 pounds (2 kgs) See cutaway view on page 2; dimensions on page 14.</p> 	V1
Hazardous Locations (UL Listed/CSA Certified, ATEX and SAA Approved Snap Detector)	<p>Explosion proof and weathertight. NEMA 4, 4X & IP65. Class I, Group A, B, C, D; Class II, Group E, F, G; Division 1 & 2 Electrical conduit connection: 3/4" NPT(F) Material: 356 aluminum Use AG detecting element; hermetically sealed SS capsule Shipping weight: 5 pounds (2.5 kgs)</p> 	V3

Adjustable Dead Band Pressure Detectors

Step 3: Detecting Elements

5V1-LA3-N6-C1A-YY

Detecting Element Service	Contact Form	Electrical Connection Type	AC Rating		DC Rating Resistive				Maximum Ambient Temperature		Designator	
			Volts	Amps	Volts	Amps	Volts	Amps	Deg F	Deg C	SPDT	DPDT
Normal Service AC	SPDT	Screw Terminal Block	24	15	24	.5	24	10*	180	80	LA	N/A
Very High Capacity DC Magnetic Blow-out			24	10	24	1.5 Min. 10.0 Max.	-	-	180	80	SA	N/A
AC or DC	DPDT	18" 18 AWG color-coded wire leads 3/4" NPT(M) conduit connection	24	11	24	.5*	24	5.0	160	70	N/A	AG

- The detecting elements shown above are UL Listed and CSA Certified. The DC current rating marked (*) is not UL Listed but has been verified by testing and/or experienced.
- The hermetically sealed detecting element capsule is UL Listed, CSA Certified and SAA Approved as a snap detector in accordance with the following table.
- Consult the factory for availability of SAA Approved units.

Agency	Hazardous Location Conditions	Designator
UL Listed	Class I, Group A, B, C, D; Class II, Group #, F, G; Division 1 & 2	AG
CSA Certified		
SAA ^{Note 3} Approved	Ex s Zone 2 IIC T4 IP65 Ex tD A22 T105 °C IP65	
ATEX Approved	II 2 G EEx m II	

Adjustable Dead Band Pressure Detectors

Step 4: Diaphragm and O-Ring

5V1-LA3-N6-C1A-YY

Notes

1. N4 diaphragm system is standard. It is normally suitable for air, oil, water and non-corrosive processes.
2. Other diaphragm and o-ring combinations may be available. Consult the factory or the SOR representative in your area for more information.
3. Wetted parts have been selected as representing the most suitable commercially available material for use in the service intended. However, they do not constitute a guarantee against corrosion or permeation, since processes vary from plant to plant and concentration of harmful fluids, gases or solids vary from time to time in a given process. Empirical experience by users should be the final guide. Alternate materials based on this are generally available.
4. Specify N3 diaphragm system for high cycle rate, high shock applications where Buna-N and TCP are compatible with the process.
5. This table shows allowable minimum and maximum temperature for o-rings.

O-Ring Material	° F	° C
Viton	32 to 400	0 to 204
Viton GLT	-20 to 400	-29 to 204
Kalrez*	5 to 400	-15 to 204
Aflas	25 to 400	-4 to 204
Buna-N Neoprene EPR	-30 to 200	-34 to 93
TCP Teflon Coated Polyimide Diaphragm	-30 to 400	-34 to 204
*Kalrez or equivalent Perfluoroelastomer (FFKM) o-rings		

6. M9 diaphragm system is suggested for steam applications up to 400°F.
7. Dead bands are slightly higher when using H, J, W, N3, or N6 series diaphragm options. Consult the factory.

O-Ring (Wetted)	Diaphragm (Wetted)	Designator	
Viton	Monel	A4	
Kalrez		A6	
Viton	Hastelloy-B	H4	
Kalrez		H6	
Viton	Hastelloy-C	J4	
Kalrez		J6	
Viton	Carpenter-20	L4	
Kalrez		L6	
Viton GLT	316L SS	M1	
Buna-N		M2	
Viton		M4	
Neoprene		M5	
Kalrez		M7	
Aflas		M8	
EPR		M9 <small>Note 6</small>	
Viton		TCP Teflon-Coated Polyimide	N1
Buna-N			N3 <small>Note 4</small>
Buna-N			N4 <small>Standard Note 1</small>
Kalrez	N5		
Kalrez	Kalrez	N6	
EPR	TCP Teflon-Coated Polyimide	N7	
Aflas		N8	
Buna-N	Buna-N	P1	
Neoprene	Neoprene	R1	
Viton	Viton	S1	
Viton GLT		S2	
Buna-N	Tantalum	W2	
Viton		W4	
Neoprene		W5	
Kalrez		W6	
EPR Ethylene Propylene	EPR Ethylene Propylene	Y1	

Adjustable Dead Band Pressure Detectors

Step 5: Pressure Port

5V1-LA3-N6-C1A-YY

Material	Connection	Designator
Aluminum Alloy 356 copper-free casting	1/4" NPT(F)	B1A
	1/2" NPT (F)	B2A
316SS CF-8M Casting	1/4" NPT(F)	C1A
	1/2" NPT (F)	C2A

Step 6: Accessories

5V1-LA3-N6-C1A-YY

Accessory / Option & Description	Designator
Wetted parts are cleaned for industrial oxygen service.	BB
CSA Certified pressure detector. Available with V1 housing. Housing has earth (ground) lug. See agency listings on page 10 for details.	CS
Cemented cover gasket on weathertight housing.	GC
Universal terminal box, 1/2" NPT(F). 316SS. Explosion proof. FM Approved; CSA Certified. See form 657 (Catalog GI-30).	HT
Vacuum protector plate retains diaphragm system in the pressure detector if subjected to intermittent vacuum greater than 10 in Hg. If a pressure detector is subjected to continuous, rapid changes of vacuum, other protection may be available (consult factory). Material matches or exceeds pressure port material.	MM
Compliance to NACE Certification MR0175/ISO 15156*	NC
Pipe (stanchion) mounting kit for (1-1/2" to 2" pipe). Order as a separate line item for CSA Certified pressure detectors.	PK
Tag, fiber. Attached with plastic wire to housing. Stamped with customer-specified tagging information.	PP
Powder coat epoxy coating. No coating on stainless steel parts or plated screws. (500 hours-salt spray)	PY
Tag, stainless steel. Attached with stainless steel wire to housing. Stamped with customer specified tagging information. (2 lines, 18 characters and spaces per line.)	RR
Stainless steel piston and cylinder disc for corrosion resistance.	SP
Explosion proof and weathertight electrical junction box with screw terminals. Aluminum 3/4" NPT(F) top or right conduit connections as required. UL Listed and CSA Certified Class I, Groups A, B, C & D; Class II, Group E, F & G; Division 1 & 2. Includes cover o-ring for weathertight applications. (V3 housing only.)	TB
Oversize stainless steel nameplate. Permanently attached to housing. Stamped with customer specified tagging information	TT
Fungicidal varnish. Covers exterior and interior except working parts.	VV
Epoxy coating. Exterior only. Polyimide epoxy with 316SS pigment. (200 hours-salt spray)	YY
Chained cover with captive screws to conform to former JIC specification	ZZ
"X" is used as a suffix to the model number for special requirements not keyed elsewhere in the model number by an "X". Each "X" must be completely identified in the text of the order or inquiry. When more than one "X" is required, use "X" followed by the number of such items. For example, "X3" means three separate, otherwise unidentifiable requirements.	X

Adjustable Dead Band Pressure Detectors

Test Certificates

Certificates	C1	C2	C3	C4	C5	C6	C8	B1	B4	B5	B6	B7	A1	A2	A3	A4	A5	A6	A7	A8
Calibration	◆							◆	◆	◆	◆	◆	◆	◆	◆	◆	◆	◆	◆	◆
Hydrostatic Pressure Test		◆						◆	◆					◆	◆	◆	◆	◆	◆	◆
Inspection Report			◆					◆	◆	◆	◆	◆			◆	◆		◆	◆	◆
Compliance / Conformance				◆								◆	◆	◆		◆	◆			◆
Dielectric Test					◆				◆	◆										◆
Insulation Resistance						◆			◆	◆	◆								◆	◆
Typical Material of Wetted Parts							◆	◆	◆				◆				◆	◆		

Agency Listings

The following combinations only are available as approved, certified or listed by the agencies shown. Some components are for products not offered in this catalog. Certain components or combinations may acquire additional approval, certification or listing between print dates of this catalog. Contact the factory for the most current information.

CSA Enclosure 4 (Weathertight)

Piston	Housing	Detecting Element	Spring	Diaphragm & O-Ring	Pressure Port Material & Connection Size	Accessories/ Option
All	V1	LA, SA	All	All	All	CS Required All except TB

SOR recognizes that there is no industry convention with respect to terminology and definitions pertinent to pressure detectors. This glossary applies to SOR Pressure Detectors.

Adjustable Range

The span of pressure between upper and lower limits within which the pressure detector may be adjusted to actuate/deactuate.

Dead Band

The difference in pressure between the increasing Set Point and decreasing Set Point.

Decreasing Set Point

That discrete pressure at which the pressure detector is adjusted to deactuate on falling pressure. It must fall within the adjustable range.

Hermetically Sealed

A welded steel capsule with glass-to-metal, factory-sealed, electrical leads that isolates the electrical detecting element(s) from the environment.

Increasing Set Point

That discrete pressure at which the pressure detector is adjusted to actuate on rising pressure. It must fall within the adjustable range.

Overrange

The maximum input pressure that may be continuously applied to the pressure detector without causing permanent change of Set Point, leakage or material failure.

Pressure Detector

A bi-stable electromechanical device that actuates/deactuates one or more electrical detecting element(s) at a predetermined discrete pressure/vacuum (Set Point) upon rising or falling pressure/vacuum.

Proof Pressure

The maximum input pressure that may be continuously applied to the pressure detector without causing leakage or catastrophic material failure. Permanent change of Set Point may occur, or the device may be rendered inoperative.

Repeatability

The ability of a pressure detector to successively operate at a Set Point that is approached from a starting point in the same direction and returns to the starting point over three consecutive cycles to establish a pressure profile. The closeness of the measured Set Point values is normally expressed as a percentage of full scale (maximum adjustable range pressure).

SPDT Detecting Element

Single-Pole, Double Throw (SPDT) has three connections: C – Common, NO – Normally Open and NC – Normally Closed, which allows the detecting element to be electrically connected to the circuit in either NO or NC state.

DPDT Detecting Element

DPDT is two synchronized SPDT detecting elements which actuate together at increasing Set Point and deactuate together at decreasing Set Point. Discrete SPDT detecting elements allow two independent circuits to be detected; i.e., one AC and one DC.

The synchronization linkage is factory set, and is not field adjustable. Synchronization is verified by connecting test lamps to the detecting elements and observing them go “On” simultaneously at actuation and “Off” simultaneously at deactuation.

Adjustable Dead Band Pressure Detectors

Dimensions

Dimensions in this catalog are for reference only. They may be changed without notice. Contact the factory for certified drawings for a particular model number. Dimensions are expressed as millimeters over inches (Linear = mm/in.).

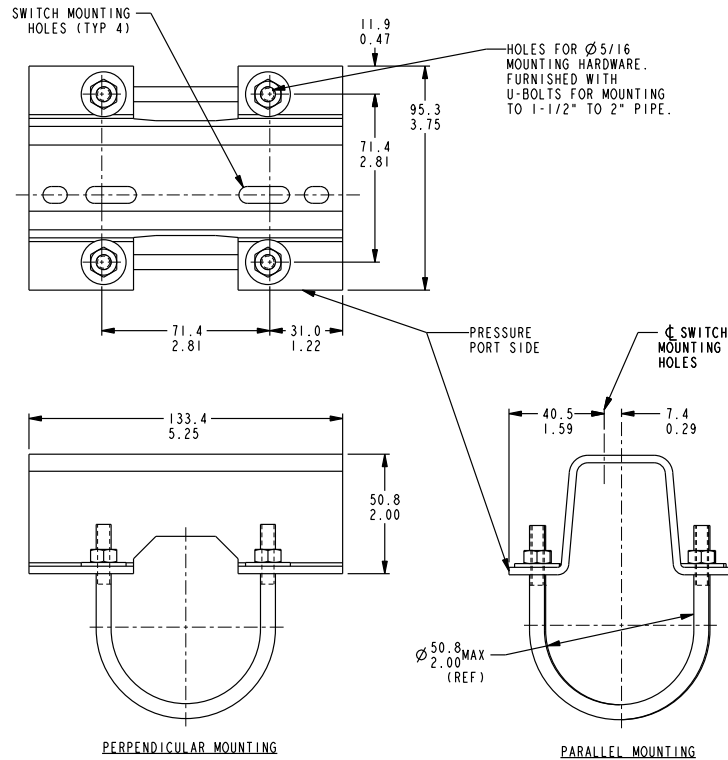

Drawing 0090300

Pipe Mounting Kit: PK

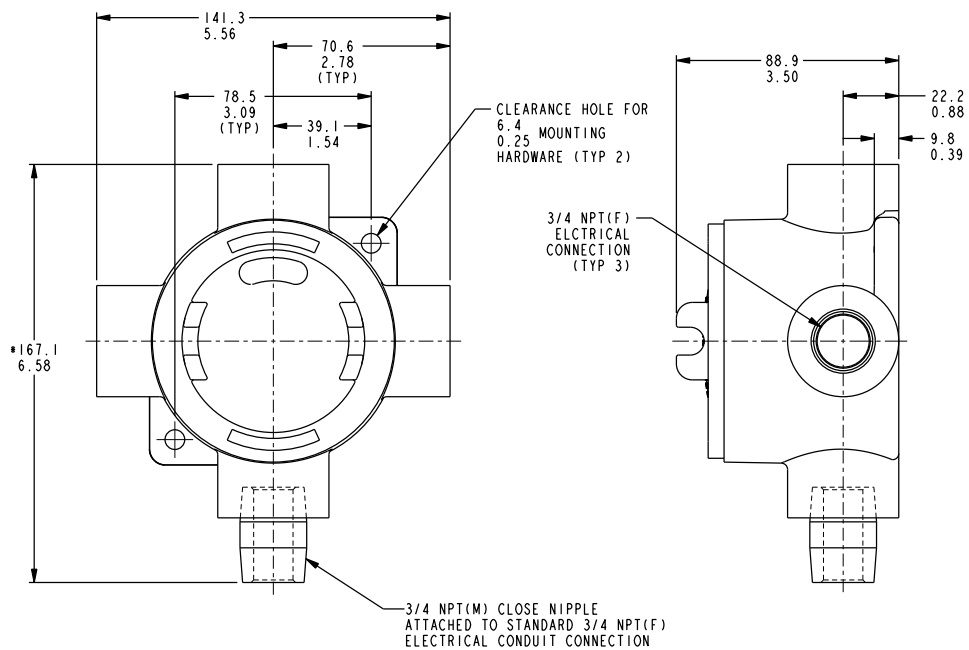

Drawing 0091353

* DIMENSION SHOWN IS APPROXIMATE AND BASED ON A 5-THREAD ENGAGEMENT.

Junction Box with Terminal Block: TB

Adjustable Dead Band Pressure Detectors

Dimensions

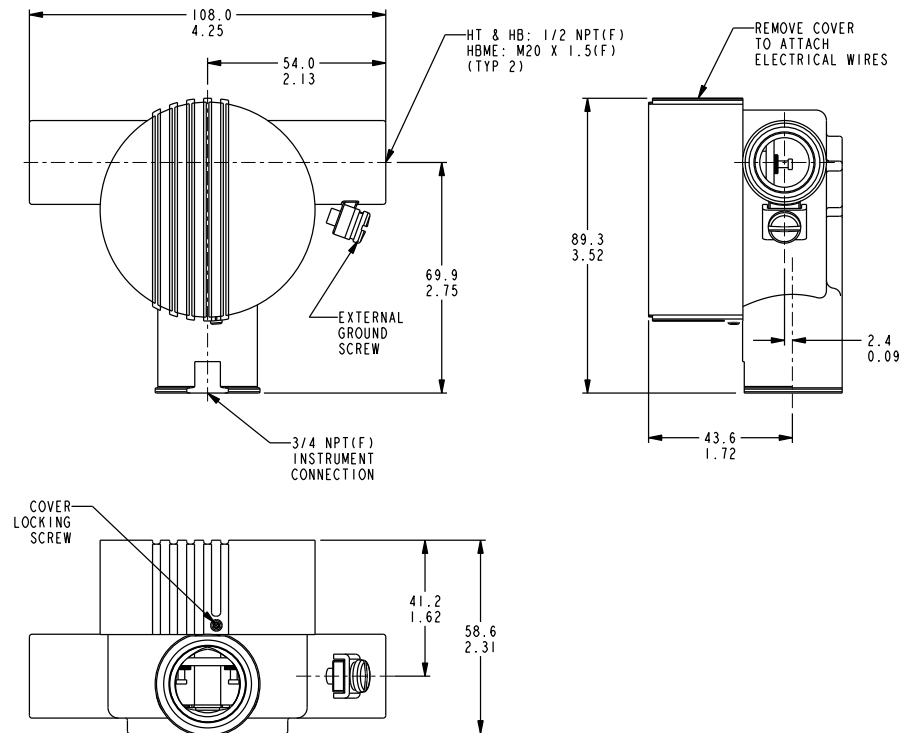

Drawing 0090763

Junction Box with Terminal Block: HT

Weights

V1 Housing	V3 Housing
4 lbs (2 kgs)	5 lbs (2.5 kgs)

Accessory	Add lbs	kgs
Pk Pipe Kit	1.5	0.7
TB Junction box with Terminal Block	5	2.25

Actual shipping weights may vary from the charted values because of product material, configuration and packaging requirements.

Adjustable Dead Band Pressure Detectors

Housing Dimensions

Dimensions in this catalog are for reference only. They may be changed without notice. Contact the factory for certified drawings for a particular model number. Dimensions are expressed as millimeters over inches (Linear = mm/in.).

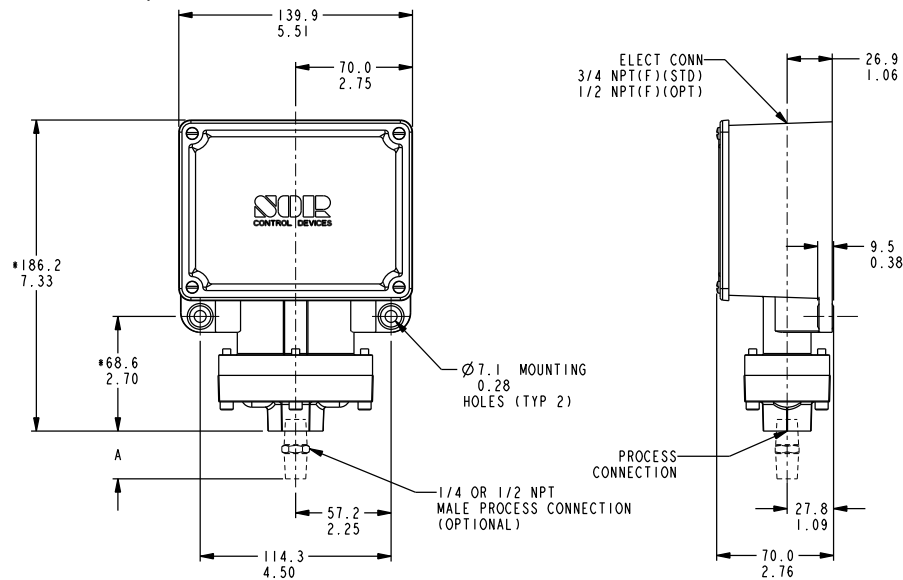

Drawing 0090236

Non-Hazardous Locations
Weathertight NEMA 4, 4X, IP65
Housing Designator: V1

• ADD 6.4 FOR ALL
 0.25 FOR ALL
 NON-ALUMINUM PORTS

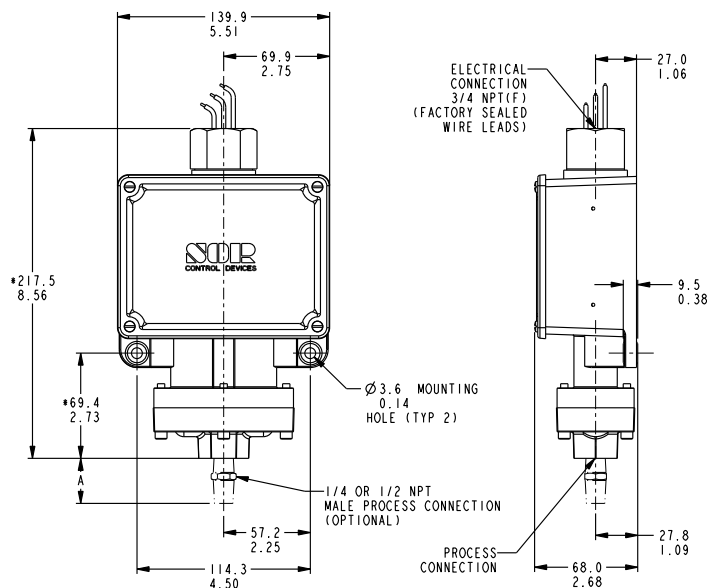

Drawing 0090325

Hazardous Locations

Contains Explosion Proof, Hermetically Sealed Detecting Element Capsule: UL Listed, CSA Certified, ATEX and SAA Approved

Housing Designator: V3

LENGTH A
 1/4 NPT(M) = 29.7 (SHOWN)
 1.17
 1/2 NPT(M) = 38.9
 1.53

SOR® offers a full line of commercial-grade process instruments.

**echOsonix®
Level Transmitters**



**Level
Detectors**



Level

**Temperature
Detectors**



Temperature Pressure

**Flow
Detectors**



Flow

**Pressure
Detectors**



Process Instrumentation

We Deliver Quality On Time