

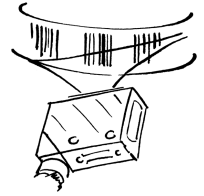

Barcode Positioning System BPS 8



Technical Description



1	General information	3
1.1	Explanation of symbols	3
1.2	Declaration of conformity	3
1.3	Description of the BPS 8 functions	4
2	Safety notices	5
2.1	General safety notices	5
2.2	Safety standards	5
2.3	Intended use	5
2.4	Working safely	6
3	Commissioning steps at a glance	8
4	Specifications BPS 8	11
4.1	General specifications BPS 8	11
4.2	Dimensioned drawings	13
4.3	Electrical connection	15
4.3.1	BPS 8 - PWR IN - Voltage supply, RS 232, Switching input/output	17
4.3.2	MA 8-01 - PWR IN HOST/RS485 - Voltage supply and RS 485	17
4.3.3	MA 8-01 - SW IN/OUT - Switching input and switching output	18
4.3.4	MA 8-01 - BPS - Connecting the BPS 8 to the MA 8-01	19
4.3.5	Connecting the RS 485 interface	20
4.4	Description of the LED states	21
4.5	Reading field curves	22
5	Connector unit	23
5.1	Modular connector unit MA 8-01	23
5.1.1	General information	23
5.1.2	Specifications of the connector unit	23
5.1.3	Dimensioned drawings	24
5.1.4	Electrical connection	25
5.1.5	Termination of the RS 485 interface	25
6	Barcode tape	26
6.1	General information	26
6.2	Specifications of the barcode tape	27
6.3	Mounting the barcode tape	28
6.4	Control barcodes	31
6.4.1	Controllable functions	32
6.5	Repair kit	34
7	Mounting	36
7.1	Mounting the BPS 8	36
7.2	Device arrangement	39
7.3	Mounting the barcode tape	40

8	Device parameters and interfaces.....	41
8.1	RS 232/RS 485 interface	41
8.1.1	General information.....	41
8.1.2	Electrical connection	41
8.1.3	BPS Configuration Tool software	43
8.1.4	Service operating mode	48
8.1.5	Overview of the parameter structure	51
8.1.6	Detailed description of the tabs.....	52
9	Protocol types for position value output.....	64
9.1	Binary protocol type 1	64
9.1.1	Data format	64
9.1.2	Telegram structure	64
9.2	Binary protocol type 2	73
9.2.1	Data format	73
9.2.2	Telegram structure	73
9.3	Binary protocol type 3	81
9.3.1	Data format	81
9.3.2	Telegram structure	81
10	Diagnostics and troubleshooting.....	85
10.1	General causes of errors	85
10.2	Error on interface	85
11	Type overview and accessories	87
11.1	Type overview: BPS 8.....	87
11.2	Accessory: Modular connector unit.....	87
11.3	Accessory: Cables	87
11.3.1	Contact assignment of PWR IN connection cable.....	88
11.4	Accessory: Configuration software	88
11.5	Accessory: Mounting device	88
11.6	Type overview: Barcode tape	88
12	Maintenance	89
12.1	General Maintenance Information.....	89
12.2	Repairs, servicing	89
12.3	Disassembling, packing, disposing	89
13	Appendix.....	90
13.1	EU Declaration of Conformity	90

1 General information

1.1 Explanation of symbols

The symbols used in this operating manual are explained below.



Attention!

This symbol appears before text passages which must absolutely be observed. Failure to heed this information can lead to injuries to personnel or damage to the equipment.



Attention Laser!

This symbol warns of possible danger through hazardous laser radiation.



Notice!

This symbol indicates text passages containing important information.

1.2 Declaration of conformity

The barcode positioning system BPS 8 and the optional connector unit MA 8 have been developed and manufactured under observation of the applicable European standards and directives.



Notice!

A copy of all declarations of conformity available for the product can be found in the appendix of this manual (see chapter 13.1 "EU Declaration of Conformity" on page 90).

The manufacturer of the product, Leuze electronic GmbH + Co. KG in D-73277 Owen/Teck, possesses a certified quality assurance system in accordance with ISO 9001.



1.3 Description of the BPS 8 functions

The BPS 8 uses visible red laser light to determine its position relative to the barcode tape. This essentially takes place in three steps:

1. Reading a code on the barcode tape
2. Determining the position of the read code in the scanning area of the scanning beam
3. Calculating the position to within a millimetre using the code information and the code position relative to the device's centre.

The position value is then output via the interface.

2 Safety notices

2.1 General safety notices

Documentation

All entries in this technical description must be heeded, in particular those in section "Safety notices". Keep this technical description in a safe place. It should be accessible at all times.

Safety regulations

Observe the locally applicable legal regulations and the rules of the employer's liability insurance association.

Repair

Repairs must only be carried out by the manufacturer or an authorised representative.

2.2 Safety standards

The BPS 8 series was developed, manufactured and tested in accordance with the applicable safety standards. It corresponds to the state of the art.

2.3 Intended use

The barcode positioning system of the BPS 8 device series is an optical measuring system which uses visible red laser light to determine the position of the BPS relative to a permanently mounted barcode tape.

The optional connector and interface unit MA 8-01 is intended for the easy connection of barcode positioning systems of type BPS 8.

In particular, unauthorised uses include:

- rooms with explosive atmospheres
- operation for medical purposes



Attention!

The protection of personnel and the device is guaranteed only if the device is operated in a manner corresponding to its intended use.

Areas of application

The barcode positioning system BPS 8 has been developed for positioning tasks in the following areas of application:

- Crane bridges and trolleys
- Side-tracking skates
- Telfer lines
- Lifts

2.4 Working safely



Attention!

Access to or changes on the device, except where expressly described in this operating manual, are not authorised.

Safety regulations

Observe the locally applicable legal regulations and the rules of the employer's liability insurance association.

Qualified personnel

Mounting, commissioning and maintenance of the device may only be carried out by qualified personnel.

Electrical work must be carried out by a certified electrician.



Attention, laser radiation!

Warning: The barcode positioning system BPS 8 operates with a red light laser of class 2 acc. to EN 60825-1. If you look into the beam path over a longer time period, the retina of your eye may be damaged!

Never look directly into the beam path!

Do not point the laser beam of the BPS 8 at persons!

When mounting and aligning the BPS 8, avoid reflections of the laser beam off reflective surfaces!

Heed the laser safety regulations according to DIN EN 60825-1 in their most current version! The output power of the laser beam at the reading window is at most 1.3mW acc. to EN 60825-1.

The BPS 8 uses a laser diode with low power in the visible red light range with an emitted wavelength of 650nm.



Attention!

CAUTION! The use of operating and adjusting devices other than those specified here or carrying out of differing procedures may lead to dangerous exposure to radiation!



Notice!

It is important that you attach the stick-on labels supplied to the device (notice signs and laser emission symbol)! If the signs would be covered due to the installation situation of the BPS 8, attach them close to the BPS 8 such that reading the notices cannot lead to looking into the laser beam!

The barcode positioning system BPS 8 is provided with the following warning notices on the housing, as well as below and next to the reading window:

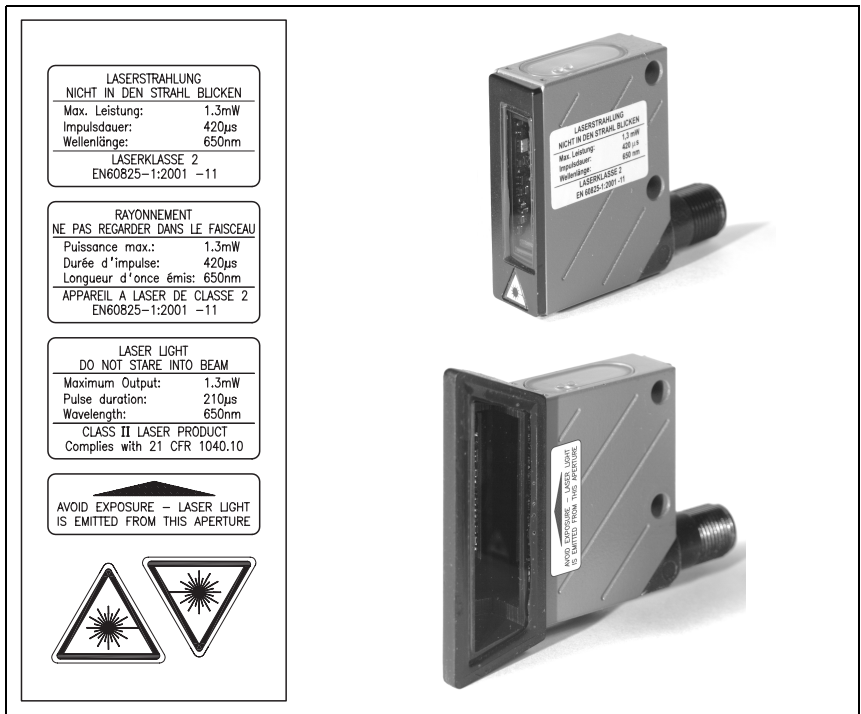

Figure 2.1: Attachment of the sticky labels with warning notices at the BPS 8

3 Commissioning steps at a glance



Notice!

Below you will find a **short description for the initial commissioning** of the barcode positioning system BPS 8. Detailed explanations for all listed points can be found throughout the manual.

1

Mechanical design

Mounting the barcode tape

The barcode tape is to be affixed without tension to a dust- and grease-free mounting surface.

→ chapter 6.3 on page 28

Mounting the BPS 8 device

There are two different types of mounting arrangements for the BPS 8:

1. Directly, using the two through holes in the housing.
2. Using a mounting device (BT 8-01) on the through holes.



Notice!

The installation dimensions listed in figure 3.1 and figure 3.2 must absolutely be adhered to. Optically, it must be ensured that the scanner has an unobstructed view of the barcode tape at all times. → chapter 7.2 on page 39

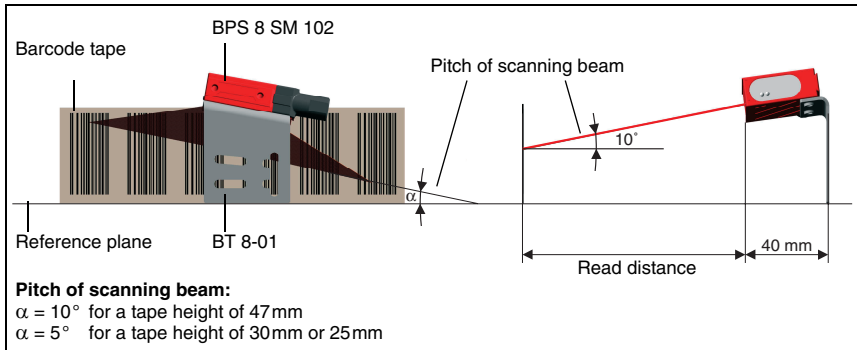

Figure 3.1: Beam exit and device arrangement for the BPS 8 SM 102



Notice!

When mounting, consider the angle of inclination α of 10° for a barcode tape height of 47 mm, 5° for a barcode tape height of 30 mm, or 25 mm in the vertical direction, and the working range of the reading field curve.

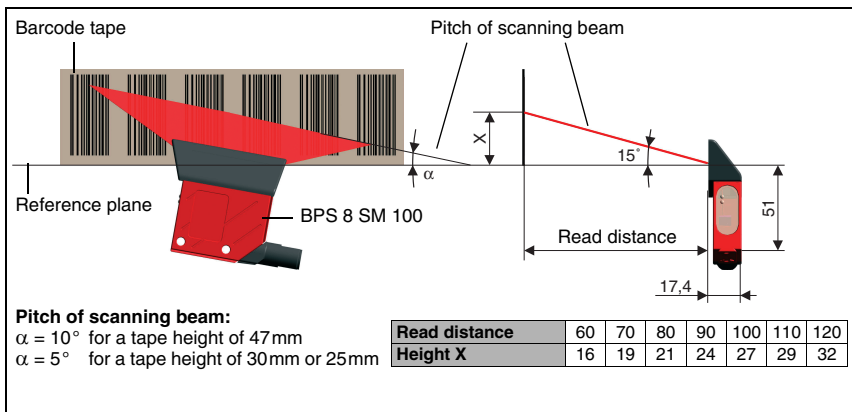

Figure 3.2: Beam exit and device arrangement for the BPS 8 SM 100



Notice!

When mounting, consider the angle of inclination α of 10° for a barcode tape height of 47 mm, 5° for a barcode tape height of 30 mm, or 25 mm in the vertical direction, and the working range of the reading field curve.

→ chapter 7.1 on page 36



Attention!

For the position calculation, the scanning beam of the BPS 8 must be incident on the barcode tape without interruption. Ensure that the scanning beam is always incident on the barcode tape when the system is moving.

Connecting voltage supply and interface



Connecting the voltage supply/RS 232 directly at the BPS 8

The voltage supply and the RS 232 interface are connected via the M12 connection **PWR IN** at the BPS 8.

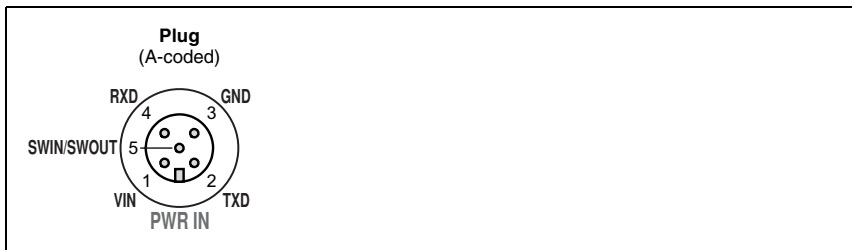

Figure 3.3: BPS 8 - assignment M12 connector PWR IN

3 *Connecting the voltage supply/RS 485 at the MA 8-01*

The BPS 8 is connected to the MA 8-01 via the connection cable KB 008-1000AA. The voltage supply and the RS 485 interface are connected to the MA 8-01 via the M12 connector **PWR IN HOST/RS485**.

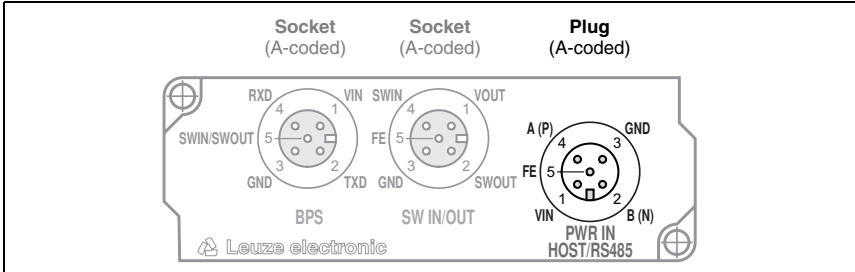

Figure 3.4: BPS 8 - Connection of voltage supply and RS 485 at the MA 8-01

4 *Connecting the switching input / switching output at the MA 8-01*

The switching input and the switching output are connected via the M12 connection **SW IN/OUT** at the MA 8-01.

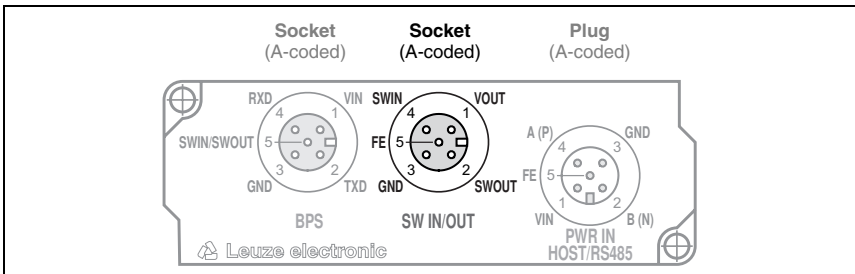

Figure 3.5: BPS 8 - Connection of switching input/output at the MA 8-01

5 *Connecting the BPS 8 to the MA 8-01*

The BPS 8 is connected to the MA 8-01 via the connection cable KB 008-1000AA. The connection to the MA 8-01 is made via the M12 connector **BPS**.

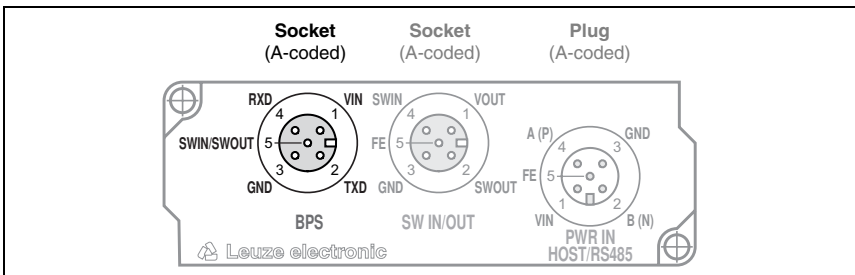

Figure 3.6: BPS 8 - Connection to the MA 8-01

4 Specifications BPS 8

4.1 General specifications BPS 8

Optical data

Light source	laser diode 650nm
Beam deflection	by means of rotating polygon mirror wheel
Reading distance	see reading field (figure 4.12 and figure 4.13 on page 22)
Optical window	glass with scratch-resistant Indium coating
Laser safety class	2 acc. to EN 60825-1, II acc. to CDRH (U.S. 21 CFR 1040.10 and 1040.11)

Measurement data

Reproducible accuracy	±1 (2)mm
Integration time	26.6 (13.3)ms
Measurement value output	3.3ms (300 values/s)
Working range	BPS 8 SM 102: 80 ... 140mm BPS 8 SM 100: 60 ... 120mm
Max. traverse rate	4m/s

Electrical data

Interface type	RS 232, RS 485 in combination with MA 8-01
Service interface	RS 232 directly at the BPS 8, RS 485 via MA 8-01, with default data format, 9600Bd, 8 data bits, no parity, 1 stop bit
Switching input / output	1 switching input, 1 switching output, both programmable, in combination with MA 8-01 only
LED green	device ready (Power On)
Operating voltage	BPS 8: 4.9 ... 5.4VDC with MA 8-01: 10 ... 30VDC
Power consumption	BPS 8: 1.5W with MA 8-01: max. 2W

Mechanical data

Protection class	IP 67
Weight	70g
Dimensions (W x H x D)	48 x 40.3 x 15mm
Housing	diecast zinc

Environmental data

Operating temperature range	0°C ... +40°C
Storage temperature range	-20°C ... +60°C
Air humidity	max. 90% rel. humidity, non-condensing
Vibration	IEC 60068-2-6, test FC
Shock	IEC 60068-2-27, test Ea
Continuous shock	IEC 60068-2-29, test Eb
Electromagnetic compatibility	EN 55022, EN 55024, EN 61000-4-2, -3, -4 and -6, EN 61000-6-2 and -3)

Barcode tape

Max. length (measurement length)	10'000m ¹⁾
Ambient temperature	-40°C ... +120°C
Mech. properties	scratch and wipe resistant, UV resistant, moisture resistant, partly chemical resistant

1) Depends on the transmission protocol and on the configured resolution.

Table 4.1: General specifications

4.2 Dimensioned drawings

BPS 8 SM 102-01 with beam exit at the front

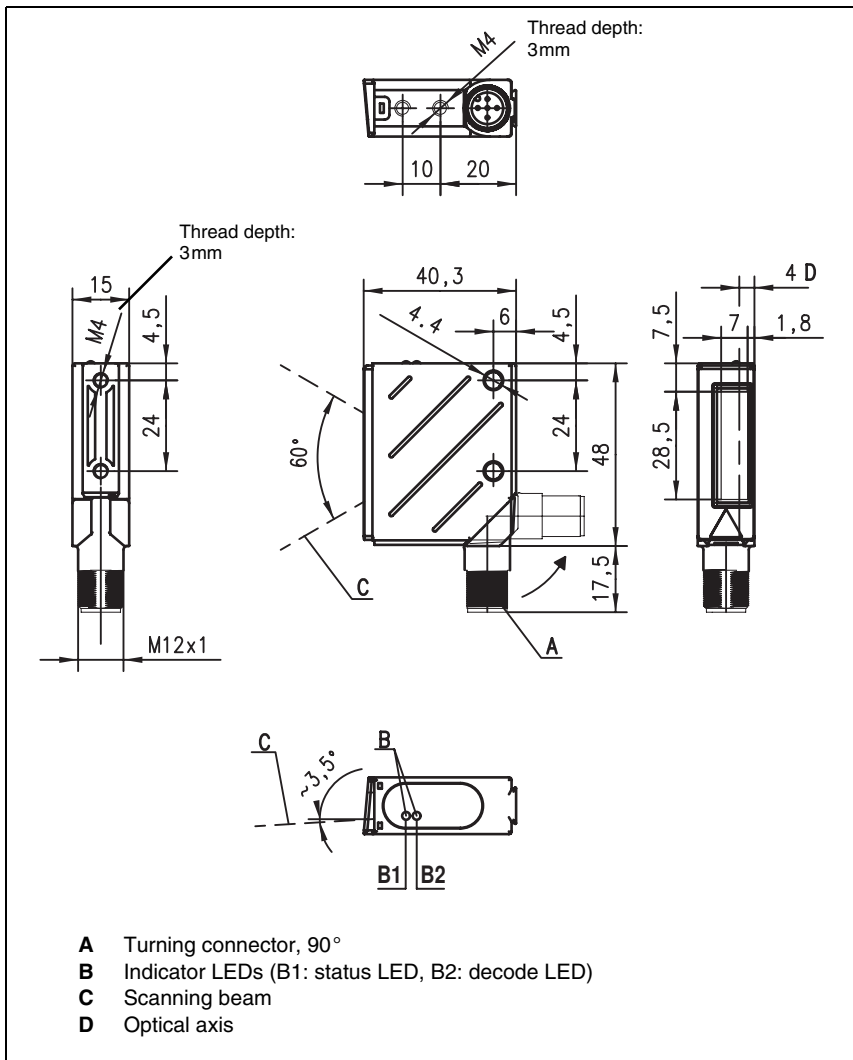

Figure 4.2: Dimensioned drawing BPS 8 SM 102-01

BPS 8 SM 100-01 with lateral beam exit

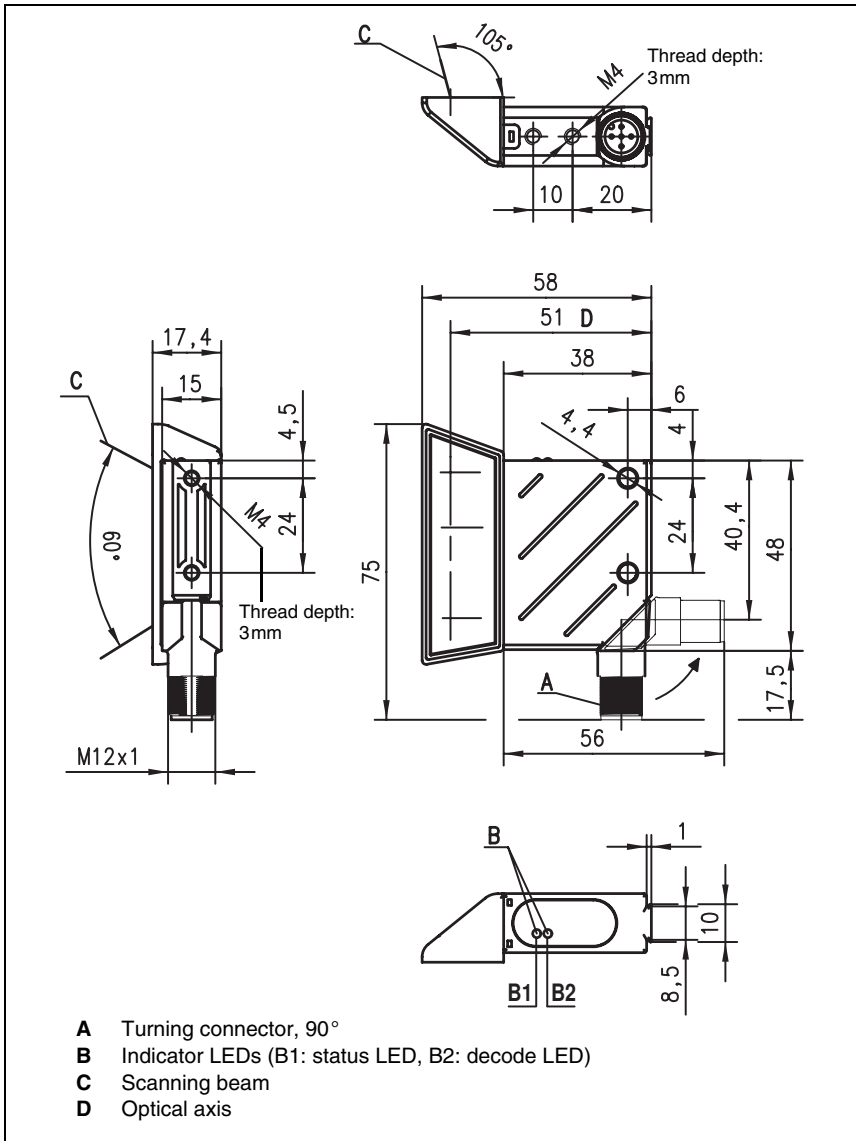

Figure 4.3: Dimensioned drawing BPS 8 SM 100-01

4.3 Electrical connection

The BPS 8 is connected to the MA 8-01 via the M12 cable KB 008-... . For the locations of the individual device connections, please refer to the device detail shown in figure 4.4.

The corresponding mating connectors and ready-made cables are available as accessories for all connections. For additional information, refer to chapter 11 starting on page 87.

**Attention!**

Connection of the device and cleaning must only be carried out by a qualified electrician.

If faults cannot be corrected, the device should be removed from operation and protected against possible use.

Before connecting the device, be sure that the supply voltage agrees with the respective values printed on the name plates of the BPS 8 or the MA 8-01.

The power supply unit for the generation of the supply voltage for the BPS 8 and the respective connector units must have a secure electrical insulation through double insulation and safety transformers according to EN 60742 (corresponds to IEC 60742).

Be sure that the functional earth is connected correctly. Error-free operation is only guaranteed if the device is connected to functional earth.

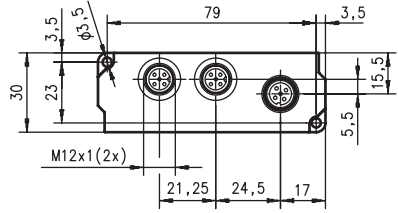

All dimensions in mm

PWR IN HOST/RS485 = Voltage supply/RS 485 host interface
 SW IN/OUT = Switching input/output
 BPS = Connection to BPS 8



Notice!

The SW IN/OUT connection is sealed with a thread plug upon delivery.

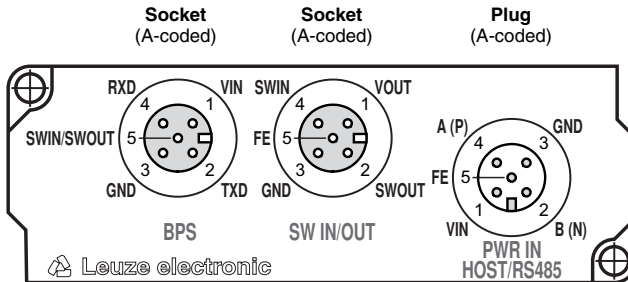

Figure 4.4: Connection assignment MA 8-01



Attention!

Protection class IP 67 is achieved only if the connectors and caps are screwed into place!

4.3.1 BPS 8 - PWR IN - Voltage supply, RS 232, Switching input/output

PWR IN (5-pin plug, A-coded)			
 <p>PWR IN M12 plug (A-coded)</p>	Pin	Name	Remark
	1	VIN	Positive supply voltage: +4.9 ... +5.4 VDC
	2	TXD	Transmission line RS 232
	3	GND	Supply voltage 0VDC
	4	RXD	Receiving line RS 232
	5	SWIN/ SWOUT	Programmable switching input/output
	Thread	FE	Functional earth (housing)

Figure 4.5: BPS 8 - Connection assignment PWR IN



Notice!

The switching input/switching output are programmed via the parameters in the configuration software **BPS Configuration Tool** in the tabs **Sensor** and **Switch**. For more information see chapter 8.1.6.4 and chapter 8.1.6.5, from **page 60** onwards.

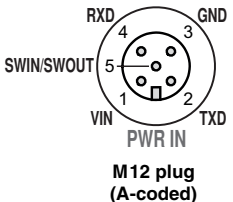

Attention!

Protection class IP 67 is achieved only if the connectors and caps are screwed into place!

4.3.2 MA 8-01 - PWR IN HOST/RS485 - Voltage supply and RS 485

PWR IN HOST/RS485 (5-pin plug, A-coded)			
 <p>PWR IN HOST/RS485 M12 plug (A-coded)</p>	Pin	Name	Remark
	1	VIN	Positive supply voltage: +10 ... +30VDC
	2	B (N)	RS 485 Receive/transmit data B-line (N)
	3	GND	Supply voltage 0VDC
	4	A (P)	Receive/transmit data A-line (P)
	5	FE	Functional earth
	Thread	FE	Functional earth (housing)

Figure 4.6: MA 8-01 - Connection assignment PWR IN HOST/RS485



Attention!

Protection class IP 67 is achieved only if the connectors and caps are screwed into place!

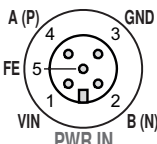
4.3.3 MA 8-01 - SW IN/OUT - Switching input and switching output

SW IN/OUT (5-pin socket, A-coded)			
	Pin	Name	Remark
 <p>SW IN/OUT M12 socket (A-coded)</p>	1	VOUT	Voltage supply for sensors (VOUT identical to VIN at PWR IN)
	2	SWOUT	Switching output
	3	GND	GND for the sensors
	4	SWIN	Switching input
	5	FE	Functional earth
	Thread	FE	Functional earth (housing)

Figure 4.7: MA 8-01 - Connection assignment SW IN/OUT



Attention!

Protection class IP 67 is achieved only if the connectors and caps are screwed into place!

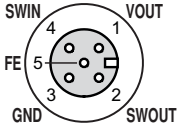

Notice!

The switching input/switching output are programmed via the parameters in the configuration software **BPS Configuration Tool** in the tabs **Sensor** and **Switch**. For more information see chapter 8.1.6.4 and chapter 8.1.6.5, from **page 60** onwards.



Attention!

If you use a sensor with a standard M12 connector, then please note the following:

Use **only sensors** on which the **switching output does not lie on pin 2** or **sensor cables on which pin 2 is not assigned**. Otherwise, the switching output is not protected against feedback on the switching input. If the inverted sensor output lies on pin 2, erroneous behaviour of the switching output will result.

Connecting the switching input / switching output

The MA 8-01 is provided with a switching input and a switching output. The connection of switching input / switching output is carried out according to figure 4.8.

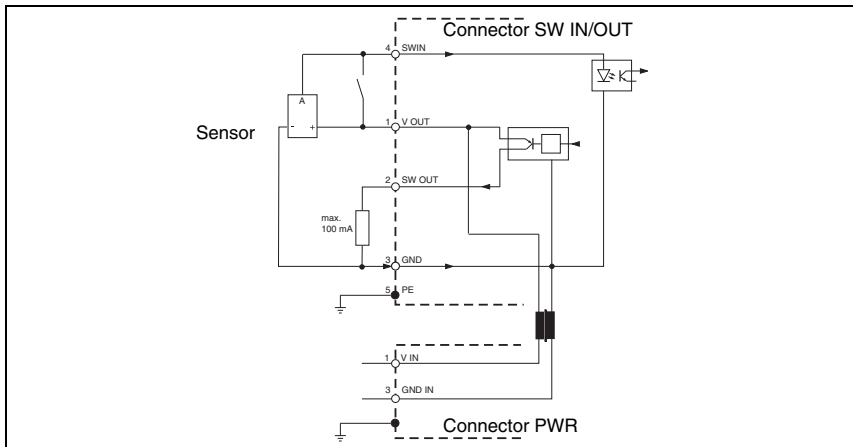

Figure 4.8: Connection of the switching input/output of the MA 8-01

4.3.4 MA 8-01 - BPS - Connecting the BPS 8 to the MA 8-01

BPS (5-pin socket, A-coded)			
	Pin	Name	Remark
<p>BPS</p> <p>M12 socket (A-coded)</p>	1	VIN	Supply voltage for BPS 8 +4.9 ... +5.4VDC
	2	TXD	Transmission line RS 232
	3	GND	Supply voltage 0VDC
	4	RXD	Receiving line RS 232
	5	SWIN/SWOUT	Programmable switching input/output of the BPS 8
	Thread	FE	Functional earth (housing)

Figure 4.9: MA 8-01 - Connection assignment BPS



Attention!

Protection class IP 67 is achieved only if the connectors and caps are screwed into place!

The BPS 8 is connected to the MA 8-01 via the connection cable KB 008-1000/2000/3000 (AA/AR). The voltage supply is connected via the **PWR IN HOST/RS485** socket.



Attention!

It is absolutely necessary to connect functional earth, since all electrical interference (EM pick-up) is discharged via the functional earth connection.

The voltage for the MA 8-01 is supplied via the connection cable KB 008-10000/5000/3000 (A/R).

Contact assignment of KB 008-10000/5000/3000 (A/R)

PWR connection cable (5-pin socket, A-coded)			
	Pin	Name	Core colour
 <p>M12 socket (A-coded)</p>	1	VIN	brown
	2	B (N)	white
	3	GND	blue
	4	A (P)	black
	5	FE	grey
	Thread	FE	Shield

Figure 4.10: Contact assignment of KB 008-10000/5000/3000 (A/R)

4.3.5 Connecting the RS 485 interface

The RS 485 interface is connected to pins 2 and 4 of the M12 connector **PWR IN HOST/RS485** at the MA 8-01.

PWR IN HOST/RS485 (5-pin plug, A-coded)			
	Pin	Name	Remark
 <p>PWR IN HOST/RS485 M12 plug (A-coded)</p>	1	VIN	Positive supply voltage: +10 ... +30VDC
	2	B (N)	RS 485 Receive/transmit data B-line (N)
	3	GND	Supply voltage 0VDC
	4	A (P)	Receive/transmit data A-line (P)
	5	FE	Functional earth
	Thread	FE	Functional earth (housing)

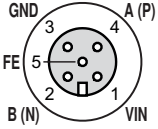
Figure 4.11: MA 8-01 - Connection assignment PWR IN HOST/RS485



Notice!

The entire connection cable must be shielded and earthed.

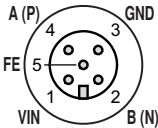

Attention!

It is absolutely necessary to connect functional earth, since all electrical interference (EM pick-up) is discharged via the functional earth connection.

Connecting functional earth FE

- **BPS 8 without cable** KB 008-10000/5000/3000 (A/R): connect **FE** to the BPS 8 housing and the cable shield!
- **BPS 8 with cable** KB 008-10000/5000/3000 (A/R): connect **FE** to the shield!
- **BPS 8 with cable** KB 008-3000/2000/1000 (AA/AR) **and MA 8-01**: connect **FE** to voltage supply shield to MA 8-01 or connect the functional earth to pin 5 of the **PWR IN** connector!

Wire Lengths and Shielding

The following maximum lengths for wires and the type of shielding to be used must be observed:

Connection	Interface	Max. wire length	Shielding
BPS 8 - Service	RS 232	10m	absolutely required, shield meshing
BPS 8/MA 8-01 - Host	RS 485	25m	absolutely required, shielded
Switching input		10m	not necessary
Switching output		10m	not necessary

4.4 Description of the LED states

Two 3-colour-LEDs at the top of the BPS 8 case show the device and reading status (see dimensioned drawings from page 13 onwards).

	LED	State	Meaning
	Status LED (B1)	Off	No supply voltage
		Green, flashing	Device initialisation
		Green, continuous light	Ready for operation
		Red, flashing	Warning
		Red, continuous light	Error, no function possible
		Orange, flashing	Service operation active
		Off	Positioning deactivated
	Decode LED (B2)	Green, continuous light	Positioning running (position value valid)
		Red, continuous light	Positioning running (position value invalid)
		Orange, continuous light	Positioning running (marker label detected)

4.5 Reading field curves

BPS 8 SM 102 with beam exit at the front

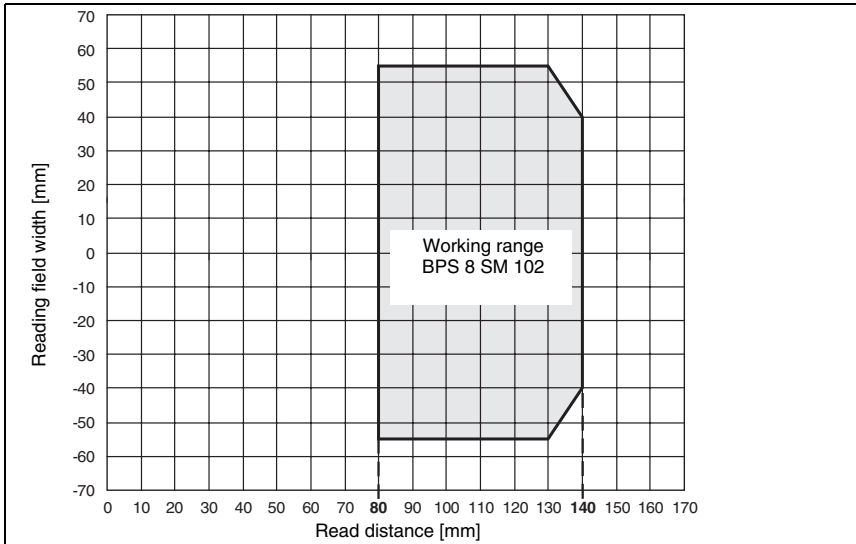

Figure 4.12: Reading field curve BPS 8 SM 102 with beam exit at the front

BPS 8 SM 100 with lateral beam exit

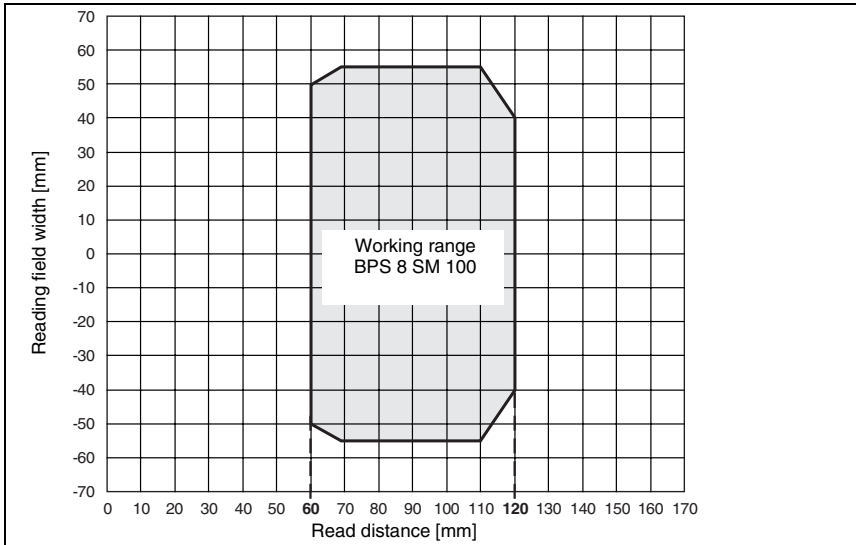

Figure 4.13: Reading field curve BPS 8 SM 100 with lateral beam exit

5 Connector unit

5.1 Modular connector unit MA 8-01

Using the RS 485 interface in a BPS 8 system always requires a MA 8-01 connector unit. The connector unit is not only used to connect to the supply voltage and the RS 485 interface, it also permits a switching input and switching output to be connected via a standard sensor connector, and connection to the BPS 8 system via ready-made cables.

5.1.1 General information

The modular connector unit is an indispensable accessory when connecting a BPS 8 to an RS 485 interface. The RS 485 interface, the switching input and the switching output are all connected to the MA 8-01. It also supplies voltage to the BPS 8.

MA 8-01

The MA 8-01 offers the following interfaces:

- M12 connection for RS 485 interface **HOST/RS485**
- M12 connection for voltage supply **PWR IN**
- M12 connection for switching input and switching output **SW IN/OUT**
- M12 connection for BPS 8 **BPS**

5.1.2 Specifications of the connector unit

Mechanical data

Protection class	IP 67 ¹⁾
Weight	70g
Dimensions (W x H x D)	86 x 30 x 25mm
Housing	plastic
Connection type	M12 connectors

Environmental data

Operating temperature range	0°C ... +50°C
Storage temperature range	-30°C ... +80°C
Air humidity	max. 90% rel. humidity, non-condensing
Standards applied	IEC 801
Electromagnetic compatibility	EN 55022, EN 61000-4-2, -3, -4 and -6, EN 61326-1, CISPR 22, class B, ITE FCC Part 15, Class B, ITE

1) with M12 connectors/caps screwed into place

5.1.3 Dimensioned drawings

MA 8-01

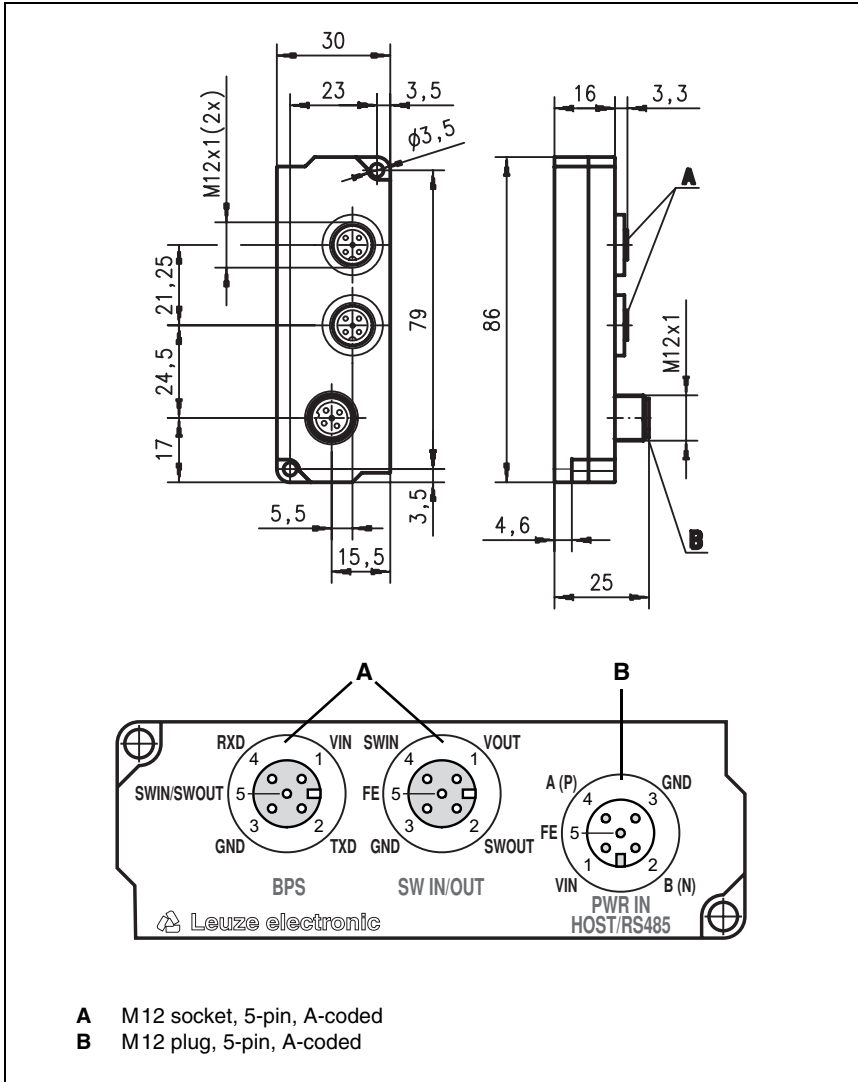

Figure 5.1: Dimensioned drawing and position/designation of the MA 8-01 connectors

5.1.4 Electrical connection

Electrical data

Interface type	RS 485
Service interface	without MA 8-01 connected: RS 232 with default data format, 9600Bd, 8 data bits, no parity, 1 stop bit with MA 8-01 connected: RS 485 replaces RS 232
Switching input / output	1 switching input, 1 switching output, each is programmable
	Switching input: 10 ... 30VDC
	Switching output: $I_{max} = 100\text{mA}$ output voltage = operating voltage
Operating voltage	10 ... 30VDC
Power consumption	max. 0.5W

5.1.5 Termination of the RS 485 interface

A permanently installed termination network is present in the MA 8-01. The network terminates the outgoing RS 485 data interface, as shown in figure 5.2, and cannot be switched off.

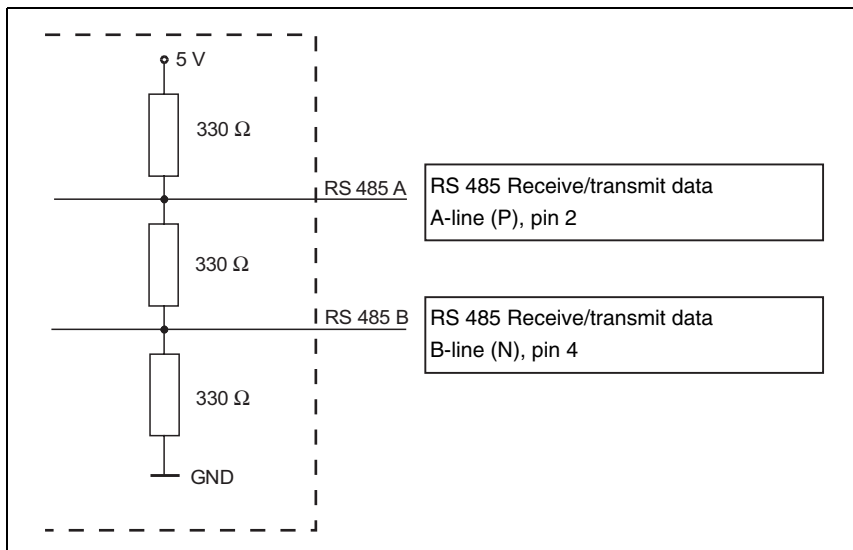

Figure 5.2: Termination of the RS 485 interface in the MA 8-01

6 Barcode tape

6.1 General information

The barcode tape (BCT) is delivered on a roll. A roll contains up to 200m of BCT, with the wrapping direction from the outside to the inside (smallest number on the outside). If a BCT is ordered which is considerably longer than 200m, the total length is divided into rolls of 200m each (see chapter 11.6 "Type overview: Barcode tape" on page 88).

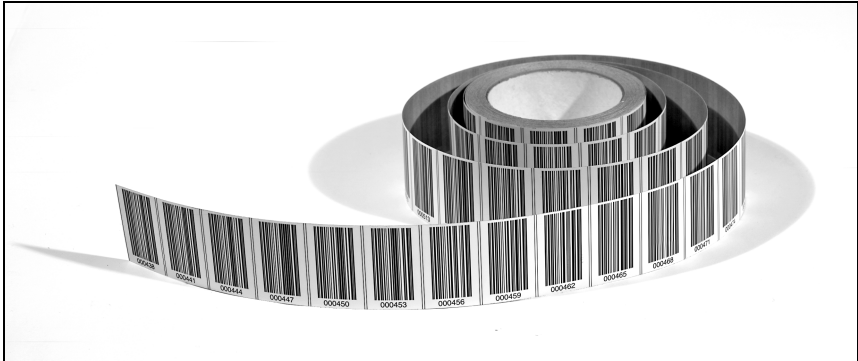

Figure 6.1: Roll with barcode tape

Features:

- Robust and durable polyester adhesive tape
- High dimensional stability
- Max. length 10'000m
- Self-adhesive, high adhesive strength



Notice!

Unlike the BPS 3x systems, the BPS 8 is optimised for a **barcode tape with position labels in a 30mm grid.**

6.2 Specifications of the barcode tape

Dimensions

Standard height	47 mm, or 30mm and 25mm
Length	0 ... 5m, 0 ... 10m, 0 ... 20m, ..., 0 ... 150m, 0 ... 200m, special lengths and special codings for lengths from 150m, for details see order guide in chapter 11.6, page 88

Construction

Manufacturing process	Filmsetting
Surface protection	Polyester, matt
Base material	Polyester film, affixed without silicone
Adhesive	Acrylate adhesive
Adhesive thickness	0.1 mm
Adhesive strength (average values)	on aluminium: 25N/25mm on steel: 25N/25mm on polycarbonate: 22N/25mm on polypropylene: 20N/25mm

Environmental data

Recom. processing temperature	0°C ... +45°C
Temperature resistance	-40°C ... +120°C
Dimensional stability	no shrinkage, tested according to DIN 30646
Curing	final curing after 72h, the position can be detected immediately by the BPS 8 after the BCT is affixed
Tearing resistance	150N
Elongation at tear	min. 80%, tested in accordance with DIN 50014, DIN 51220
Weathering resistance	UV-light, humidity, salt spray (150h/5%)
Chemical resistance (tested at 23°C for 24h)	transformer oil, diesel oil, white spirit, heptane, ethylene glycol (1:1)
Behaviour in fire	self-extinguishing after 15s, does not drip
Mounting surface	grease-free, dry, clean, smooth

Table 6.2: Specifications of the barcode tape

6.3 Mounting the barcode tape

To prevent deposits of dirt from forming, it is recommended that the BCT be affixed vertically, possibly below a roof-like cover. If the application does not permit this, permanent cleaning of the BCT by on-board cleaning devices such as brushes or sponges is not permitted in any case. Permanent on-board cleaning devices polish the BCT and give it a glossy finish. The read quality deteriorates as a result.



Notice!

When mounting the BCT, it must be ensured that neither strong sources of extraneous light nor reflections of the base on which the BCT is affixed occur in the area of the scanning beam.

The recommended interruption points on the BCT are at the provided cut marks.



Figure 6.3: Cut mark on the barcode tape



Notice!

Cutting the BCT and affixing the tape so that a gap forms which is so large that a label can no longer be reliably detected in the scanning beam results in double positions during the position calculation of the BPS. The gap must not be greater than the distance from one cut mark to the next (max. one label).

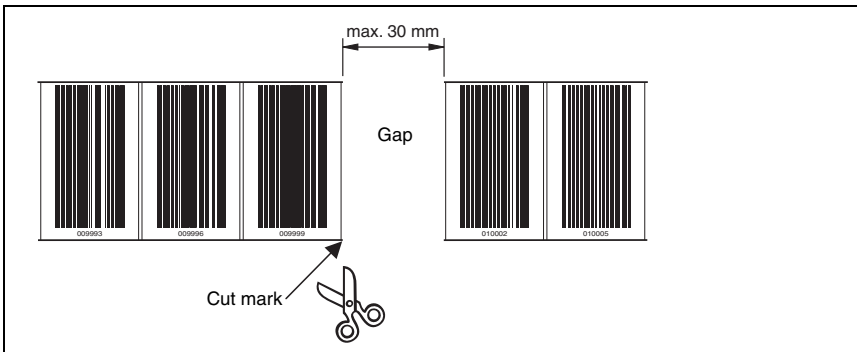

Figure 6.4: Gap in the cut barcode tape

Procedure:

- Examine the mounting surface. It must be flat, without warping, free of grease and dust, and dry.
- Define a reference edge (e.g. metal edge of the busbar)
- Remove the backing and affix the BCT along the reference edge **tension free**. Secure the BCT to the mounting surface by pressing down with the palm of your hand. When affixing, make certain that the BCT is free of folds and creases and that no air pockets form.
- Never pull the BCT. Because this is a plastic tape, forceful pulling may stretch it. This results in a distortion of the measurement units on the tape. While the BPS 8 can still perform the position calculation, the accuracy in this case is no longer ensured. If the values are taught using a teach-in process, distortions are irrelevant.
- Expansion joints with widths up to several millimetres can simply be covered with the barcode tape. The tape must not be interrupted at this location.
- Protruding screw heads can simply be taped over. Cut out the bar code which covers the screw head at the cut marks.
- If the application dictates the necessity of a gap, the tape is to be affixed over this gap and the affected cut marks cut out. If the gap is small enough that the scanning beam can detect the label to the left or to the right of the gap, measurement values are delivered without interruption. If the scanning beam cannot scan a label completely, the BPS 8 outputs a "tape error" message. As soon as the BPS 8 can scan a complete label again, it calculates the next position value.
- The maximum gap between two barcode positions without affecting the measurement value is 30mm.

**Notice!**

If the barcode tape was damaged, e.g. by falling parts, a repair kit for the BCB 8 with a raster of 30mm can be downloaded from the Internet (www.leuze.de -> **Download** -> **identify** -> **Optical barcode positioning** -> **Repair Kit for Barcode Tape BPS 8**).

**Notice!**

You can also view a video which illustrates how to affix the barcode tape on the Internet at www.leuze.de -> **Download** -> **identify** -> **Optical barcode positioning** -> **Videos** -> **How to mount...**

**Attention!**

Barcode tapes with different value ranges may not directly follow one another. If the value ranges are different, the gap between the two BCTs must be greater than the detection range of the scanning beam or control barcodes must be used (for further information see chapter 6.4 on page 31).

**Notice!**

When working with the BCT in cold warehouses, it should be ensured that the BCT be affixed before the warehouse is cooled. However, if it should be necessary to affix the BCT at temperatures outside of the specified processing temperature, please make certain that the bonding surface as well as the BCT are at the processing temperature.

**Notice!**

When working with BCT in curves, the BCT should only be partially cut at the cut mark and affixed along the curve like a fan; it must also be ensured that the BCT is affixed without tension (see figure 6.5).

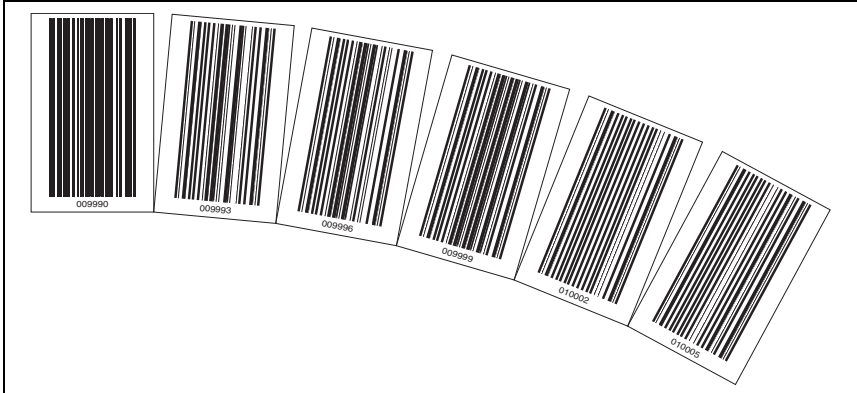

Figure 6.5: Partial cutting of the barcode tape in curves

6.4 Control barcodes

With the aid of control barcodes, which are simply affixed over the barcode tape at the necessary locations, functions can be activated and deactivated in the BPS 8.



Notice!

The control of functions using control barcodes is a new feature of the BPS 8. The implementation of additional control options via control barcodes is in preparation.

Structure of the control barcode

The control barcodes utilise code type **Code128** with character set **B**; the position barcodes, on the other hand, utilise **Code128** with character set **C**. **Code128** with character set **B** enables the display of all letters and numbers in the ASCII character set.

System arrangement

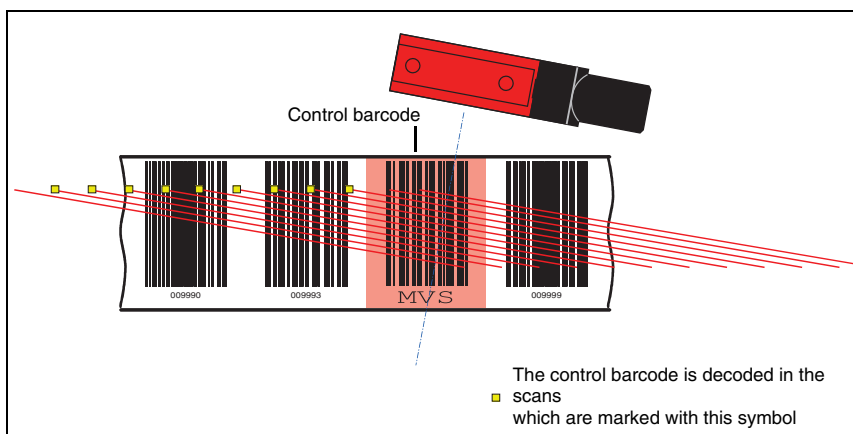

Figure 6.6: System arrangement of control barcodes

The control barcode is affixed either within one or between two barcode tapes in such a way that one position barcode is replaced or two barcode tapes are seamlessly connected to one another.



Attention!

It must be ensured that only one control barcode is located in the scanning beam at any one time. Thus, the minimum distance between two control barcodes is determined by the distance between the BPS and barcode tape and the resulting length of the scanning beam.

For error-free function, when using control barcodes it must absolutely be ensured that the distance between the BPS and barcode tape is selected large enough. The scanning beam of the BPS should cover three or more barcodes; this is ensured at a distance which lies in the working range of the reading field curve.

The control barcodes are simply affixed over the existing tape. When affixing the control barcodes, make certain to cover entire barcodes to ensure that a barcode spacing of 3cm is maintained.

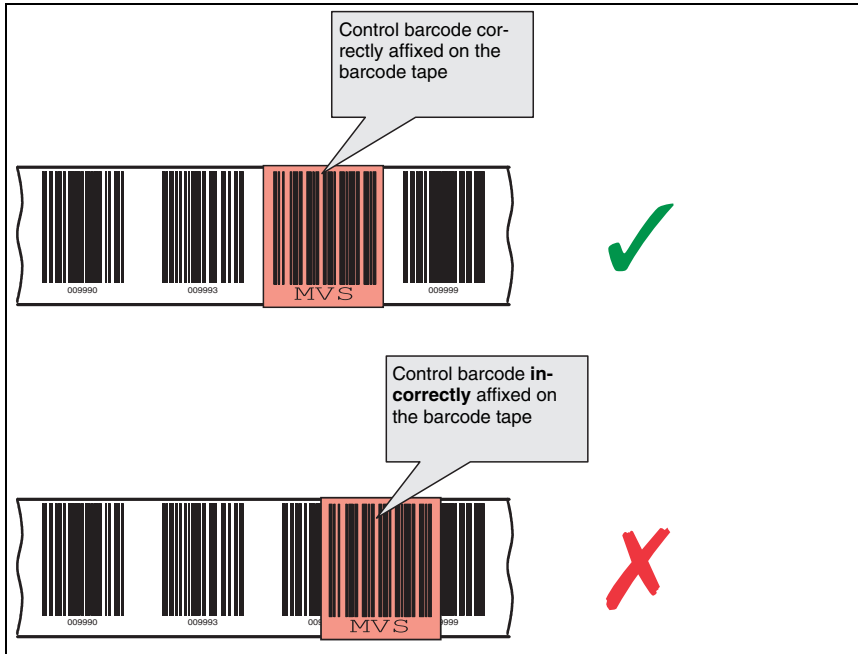

Figure 6.7: Correct positioning of the control barcode

6.4.1 Controllable functions

Measurement value switching between 2 barcode tapes with different value ranges

The "MVS" control barcode is used to switch between two barcode tapes. The end of one tape and the start of the next can end and begin, respectively, with completely different position barcodes. If the centre of the BPS 8 reaches the transition point of the control barcode, the device switches to the second tape, provided the next position label is in its scanning beam. As a result, the output position can always be uniquely associated with one tape.



Figure 6.8: "MVS" control barcode for switching between tapes

Use of the "MVS" control barcode for switching between tapes is not direction-dependent. This means that it functions for switching from tape 1 to tape 2 and vice versa.

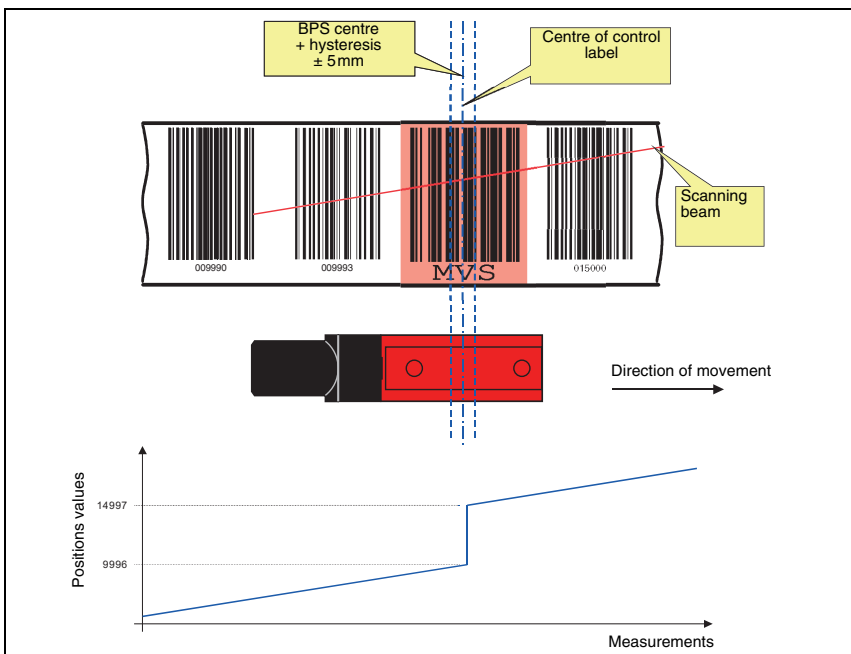

Figure 6.9: Switching position with the "MVS" control barcode

If the "MVS" label is passed over, the new tape value is always output relative to the centre of the device or label (see figure 6.9). In this situation, the hysteresis of $\pm 5\text{mm}$ is irrelevant. However, if the direction is changed after stopping within the hysteresis on the label "MVS", a switch to the previous tape value is being made, using the specified hysteresis.

**Notice!**

When affixing the BCT in a system in which the end of one BCT meets the start of another BCT (position value X with position value 0), ensure that position labels 0 ... 9 are not used. This means that position label 12 must be the first label used on the continuing barcode tape. If this correction is not carried out, negative values may be calculated.

**Notice!**

If only the "MVS" label is read within the scanning beam, the scanning beam must not be interrupted during the read operation until the scanner can again read a complete position label.

If only the "MVS" label is located in the scanning beam, the voltage on the BPS 8 must not be switched off. Otherwise the BPS 8 will return a position value of zero when the voltage is switched back on.

Moreover, the scanner must not be configured while in this position. Otherwise, a value of zero is output as long as no position label is present in the scanning beam due to the fact that the scanning beam is switched off during configuration.

6.5 Repair kit

**Notice!**

If the barcode tape was damaged, e.g. by falling parts, a repair kit for the BCB 8 with a raster of 30mm can be downloaded from the Internet (www.leuze.de -> **Download** -> **identify** -> **Optical barcode positioning** -> **Repair Kit for Barcode Tape BPS 8**).

In these 6 files you will find all code information for a tape with lengths of 0 ... 500m, 500 ... 1000m, 1000 ... 1500m ... 2500 ... 3000m. 0.9m of barcode tape is provided on each A4 sheet. The 0.9 metres are divided into 5 lines of 18cm each, with 6 code information segments of 3cm each.

Procedure when replacing the defective area:

1. Determine the coding of the defective area.
2. Print out the area determined to be defective
3. Affix the printed area over the defective location

Important note for printing:

1. Select only those pages that are actually required.
2. Change the printer settings so that the code is not distorted.
Suggestion for printer settings, see figure 6.10.
3. Verify the printing result by measuring the distance between two codes (see figure 6.11).
4. Cut the code strips and concatenate them. It is important that the code content always increases or decreases in blocks of 30 mm.

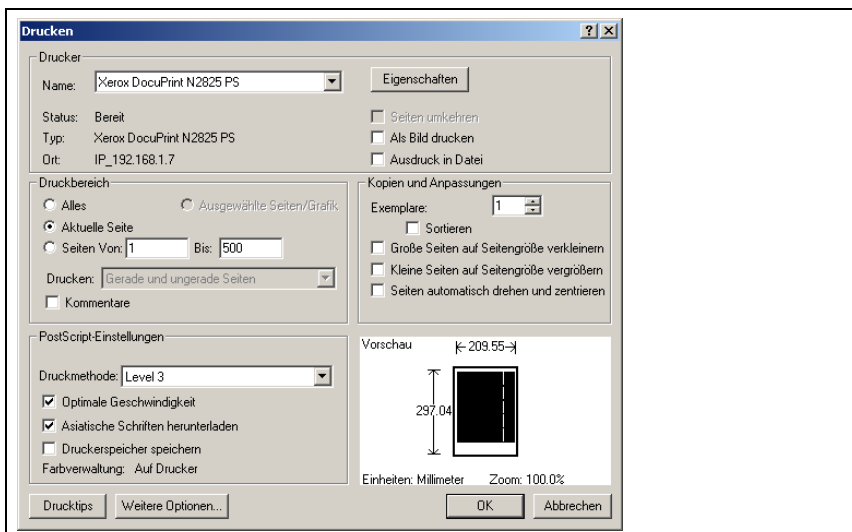

Figure 6.10: Printer settings for BCT repair kit

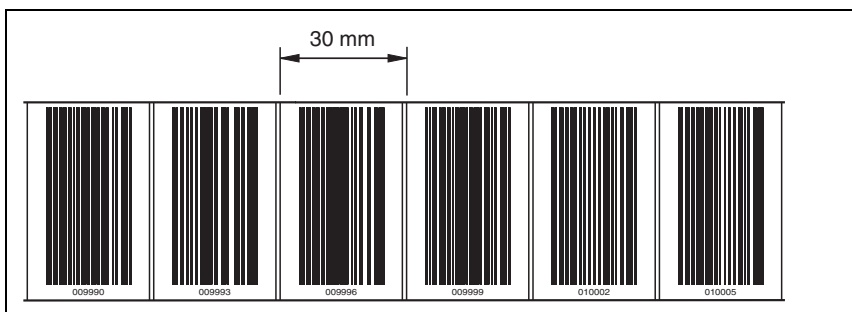

Figure 6.11: Checking the print results of the BCT repair kit

7 Mounting

7.1 Mounting the BPS 8

There are two different types of mounting arrangements for the BPS 8:

1. Directly, using the two through holes in the housing.
2. Using a mounting device (BT 8-01) on the through holes.

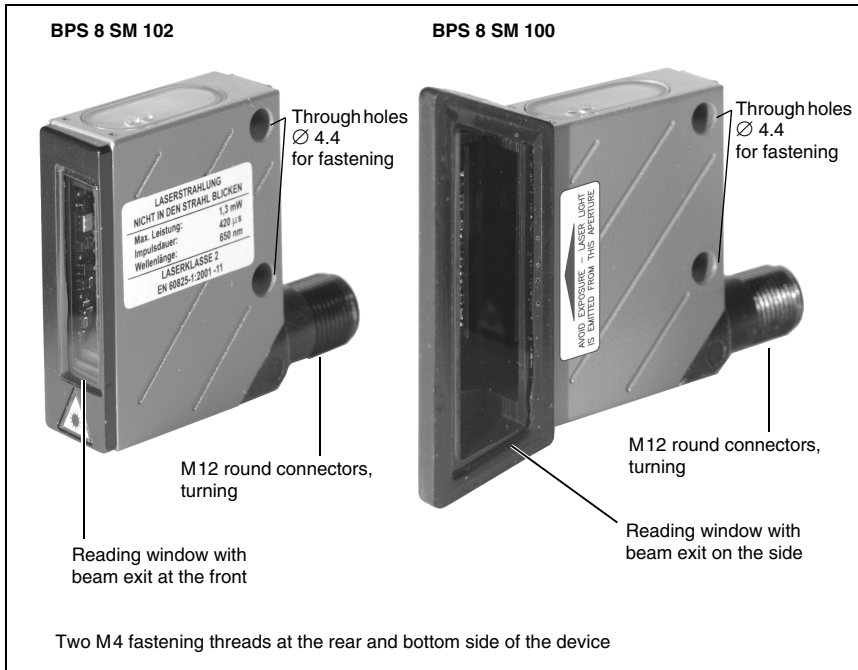

Figure 7.1: BPS 8 mounting options

BT 8-01 mounting device

The BT 8-01 mounting device is available for mounting the BPS 8 using the two through holes. It is intended for attachment via two M4 screws. For ordering instructions, please refer to chapter 11.5 on page 88.

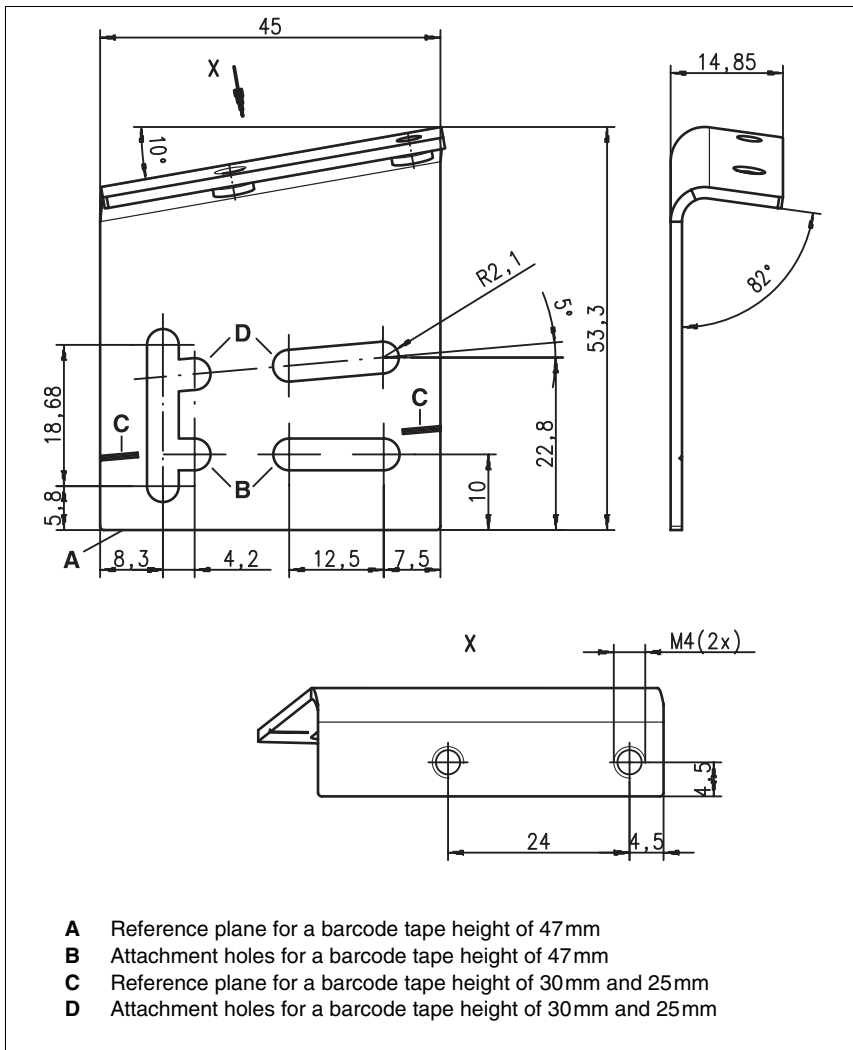

Figure 7.2: BT 8-01 mounting device

BPS 8 system components

Figure 7.3: BPS 8 system components

**Notice!**

When mounting, consider the angle of inclination of 10° for a tape height of 47mm, 5° for a tape height of 30mm, or 25mm, in the vertical direction, and the working range of the reading field curve.

**Attention!**

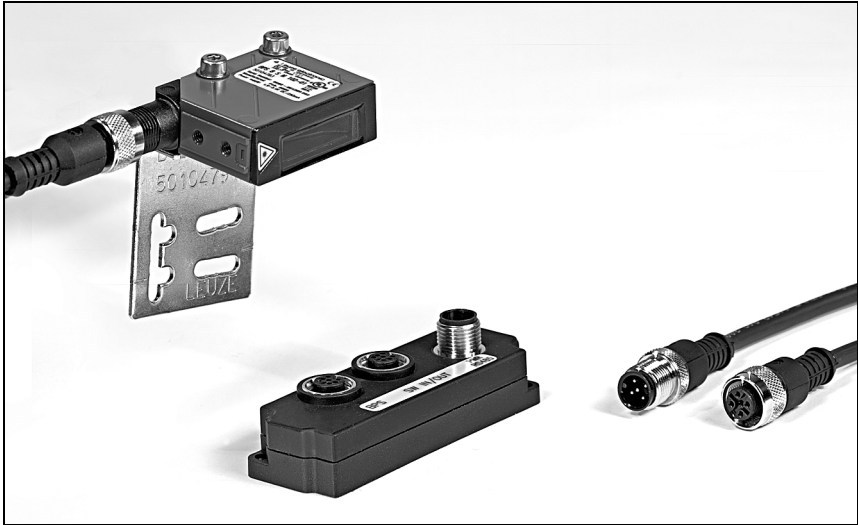
For the position calculation, the scanning beam of the BPS 8 must be incident on the barcode tape without interruption. Ensure that the scanning beam is always incident on the barcode tape when the system is moving.

7.2 Device arrangement

Selecting a mounting location

In order to select the right mounting location, several factors must be considered:

- The scanning range determined from the scanning curve must be adhered to at all locations where a position determination is to be made
- The BPS should be mounted at an angle of 10° (depending on the tape height, see notice on page 38) in the horizontal axis relative to the barcode tape to ensure continued reliable positioning results even in the event of soiling of the barcode tape.
- On the BPS 8, the beam is not emitted perpendicular to the cover of the housing, but with an angle of about 3.5° towards the bottom. To achieve a total pitch of 10°, the mounting bracket MA 8-01 has an angle of about 6.5°. This angle is intended to prevent total reflection on the barcode tape. With the angles integrated into the BT 8-01, the BPS 8 can be mounted in parallel to the barcode tape in the read distance required.

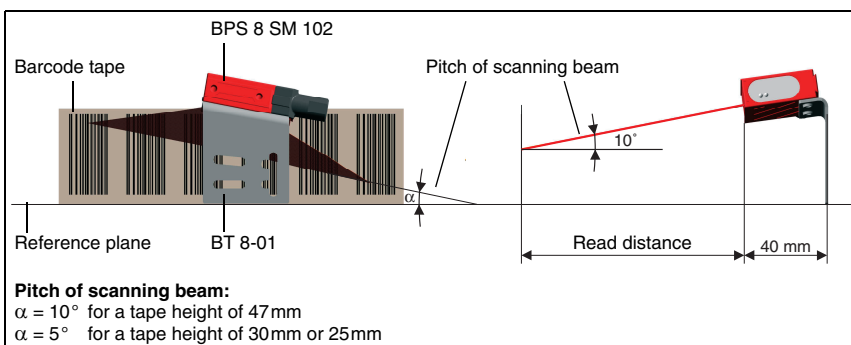

Figure 7.4: Beam exit and device arrangement of the BPS 8 SM 102

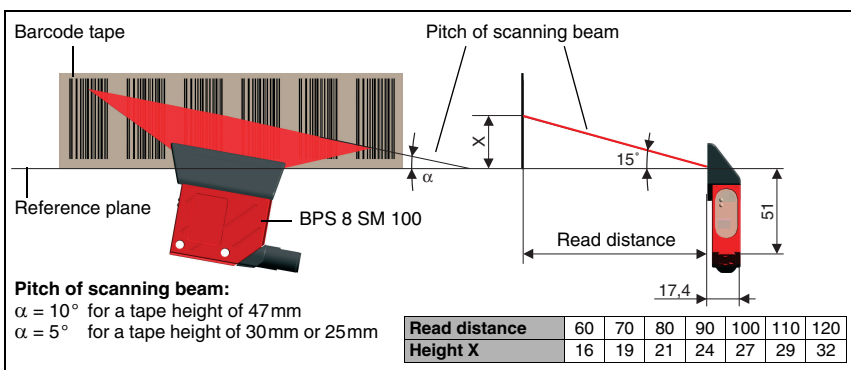

Figure 7.5: Beam exit and device arrangement for the BPS 8 SM 100

**Notice!**

The BPS 8 has to be mounted in such a way that

- the BPS is guided parallel to the tape.
- the permitted working range is not exited.

Mounting location

↳ When selecting a mounting location, pay attention to

- maintaining the required environmental conditions (non-condensing, temperature),
- possible soiling of the reading window due to liquids, abrasion by boxes, or packaging material residues.

Mounting outdoors

When mounting outdoors, also observe the following points:

- mount in such a way that the device is protected from relative wind; mount additional shields if necessary.
- when using outdoors, we recommend mounting in an additional protective housing.

**Notice!**

When installing the BPS 8 in a protective housing, it must be ensured that the scanning beam can exit the protective housing without obstruction.

7.3 Mounting the barcode tape

The BPS 8 and barcode tape combination is mounted in such a way that the scanning beam is unobstructed and is incident on the barcode tape as described in figure 7.4 on page 39.

Notice!

For further information on mounting the barcode tape, please refer to chapter 6.3 on page 28.

8 Device parameters and interfaces

8.1 RS 232/RS 485 interface

8.1.1 General information

The BPS 8 system is supplied with an RS 232 interface. Using the MA 8-01 permits this to be replaced by an RS 485 interface. All settings regarding the protocols and device parameters may be configured according to customer specifications using the **BPS Configuration Tool** software.



Notice!

The *BPS Configuration Tool* can be downloaded from the *Leuze Homepage* at www.leuze.de -> **under the heading Download -> identify -> Optical barcode positioning.**

8.1.2 Electrical connection

Connecting the voltage supply/RS 232 directly at the BPS 8

PWR IN (5-pin plug, A-coded)			
	Pin	Name	Remark
<p>M12 plug (A-coded)</p>	1	VIN	Positive supply voltage: +4.9 ... +5.4VDC
	2	TXD	Transmission line RS 232
	3	GND	Supply voltage 0VDC
	4	RXD	Receiving line RS 232
	5	SWIN/SWOUT	Programmable switching input/output
	Thread	FE	Functional earth (housing)

Figure 8.1: BPS 8 - Connection assignment PWR IN



Attention!

Protection class IP 67 is achieved only if the connectors and caps are screwed into place!

Connecting the voltage supply/RS 485 at the MA 8-01

PWR IN HOST/RS485 (5-pin plug, A-coded)			
	Pin	Name	Remark
 <p>PWR IN HOST/RS485</p> <p>M12 plug (A-coded)</p>	1	VIN	Positive supply voltage: +10 ... +30VDC
	2	B (N)	RS 485 Receive/transmit data B-line (N)
	3	GND	Supply voltage 0VDC
	4	A (P)	Receive/transmit data A-line (P)
	5	FE	Functional earth
	Thread	FE	Functional earth (housing)

Figure 8.2: MA 8-01 - Connection assignment PWR IN HOST/RS485



Attention!

Protection class IP 67 is achieved only if the connectors and caps are screwed into place!

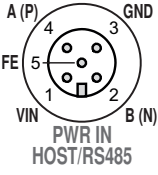

Notice!

For connection of the voltage supply and interface, we recommend our ready-made cables. For further information, see chapter 11.3 on page 87.



Attention!

Before connecting the device, be sure that the supply voltage agrees with the specified value.

Connection of the device and cleaning must only be carried out by a qualified electrician.

The power supply unit for the generation of the supply voltage for the BPS 8 and the respective connector unit must have a secure electrical insulation through double insulation and safety transformers according to EN 60742 (corresponds to IEC 60742).

Be sure that the functional earth is connected correctly. Error-free operation is only guaranteed if the device is connected to functional earth.

If faults cannot be corrected, the device should be removed from operation and protected against possible use.

To then further isolate the error, proceed as described in chapter 10 on page 85.

8.1.3 BPS Configuration Tool software

8.1.3.1 Installing the "BPS Configuration Tool" software

- ↪ Insert the installation CD into your drive
(also available as download on the Internet under www.leuze.de).
- ↪ Call up the installation file (e.g. Setup.exe)
- ↪ Select the language for your installation.

The following window appears:

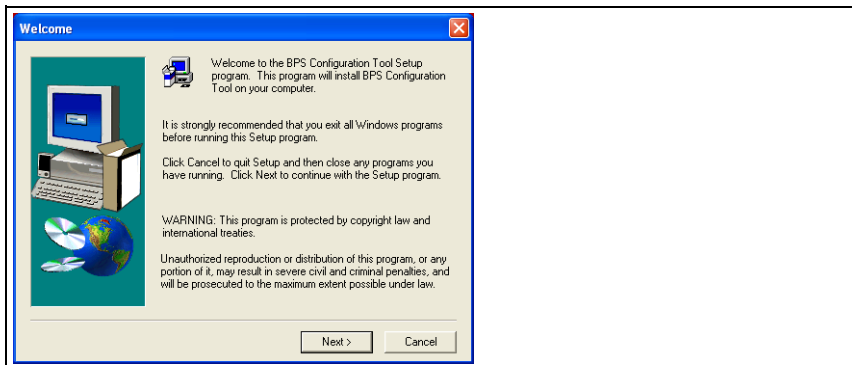

Figure 8.3: Installation window

- ↪ Confirm the following licence agreement and select the installation path in the following window:

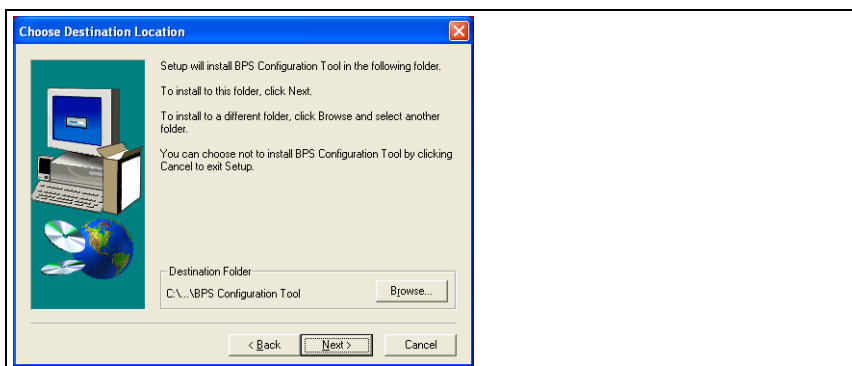

Figure 8.4: Installation directory

- ↪ Confirm your entry with Next, then follow the installation routine.
For further details please refer to online help of the "BPS Configuration Tool" software.
- ↪ After the successful installation, double-click on the **BPS Configuration Tool** icon to activate the configuration program.

8.1.3.2 Brief manual for the BPS Configuration Tool

General information

The **BPS Configuration Tool** program was developed as a convenient user-friendly tool to operate all common Leuze BPS systems.

To install the tool, double click on the **Setup.exe** file and follow the instructions. After the program has been successfully installed and started, the left side shows the standard project **Leuze electronic**. In this project, every possible device has already been created.

This project is write-protected but can be edited arbitrarily and saved under a different name using the **Project -> Save as** menu.

Creating a new project

- ☞ Select **Project -> New...** or click on the  symbol in the top left corner.
- ☞ Assign a file name. Up to 256 characters are possible.
The **.PCT** extension must remain the same.
- ☞ Assign a project name (= title) to the project. Up to 256 characters are possible.
- ☞ Enter a description if required.
- ☞ After confirmation with **OK**, the new project name is shown in the top left corner.

Create individual devices

- ☞ Left click on project name (= title)
- ☞ **Device -> New -> Single device** or click on the  symbol in the top left corner.
- ☞ Assign a device name
- ☞ Select device type (only BPS can be selected).
- ☞ Select BPS type
- ☞ Select BPS version = software version of the device
- ☞ After clicking **OK**, the new device is shown in the project.

Follow this procedure to create all devices required.



Notice!

When creating an individual device, the Leuze standard parameter set is always created together with the selected device according to the software version selected. The interface data from the PC to the device are also created together with the Leuze standard settings.

These are: **9600 / 8 / 1 / None**
 Framing protocol: **<STX><data><CR><LF>**
 Address: **none**



Copying and pasting devices

It is possible to copy and paste individual devices. To do this, the device to be copied must be selected. By clicking on the right mouse button, the **Copy** and **Paste** functions become available. Only the device settings are copied, not the deposited interface data of the PC.

Renaming devices

It is possible to rename devices. This requires the respective device to be selected. Right click on the mouse button, select **Device properties...** and enter the desired description under **Name**.

Graphical configuration

If a device is selected via the left mouse button, the window of the graphical configuration opens automatically. The graphical interface visualises the device settings and these can be loaded or transferred using the symbols  and .

For further help on device-specific parameters, the technical description for the selected device may be opened. To view the technical description for the device, click on the  symbol.

All parameters that were changed, i.e. that deviate from the Leuze factory settings, have a yellow background or frame colour or are marked with the  symbol for better orientation.

To reset all parameters of the selected device back to the Leuze factory settings, click on the  symbol. This only resets the values in the PC and not the settings in the BPS.

Tree structure configuration

The second option for working off-line is the tree structure. The tree structure contains all settings of the graphical structure plus additional parameters.

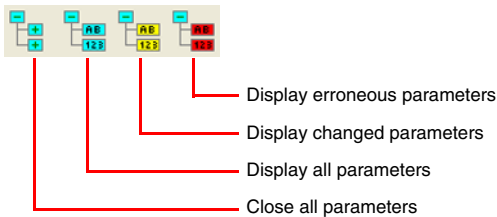









Terminal

The third option of communicating with the device is the terminal. This is only possible online.

If no device is selected, only the terminal is available. Its interface settings are available under **Options -> Communication....** They can also be selected by clicking on the communication parameters displayed in the lower status bar.

Standard commands

The right third of the terminal window shows the following symbols for direct online commands

 Factory default	— Sets all parameters in the device to the factory settings!
 Reset	— Software reset
 Version	— Version query
 Display measurement values	— Displays the measurement values on the terminal
 Do not display measurement	— Does not display the measurement values on the terminal
 Start measurement	— Starts the measurement process
 Stop measurement	— Stops the measurement process
 Version	— User-defined commands



Notice!

Please note that the device settings do not always displayed their current values if one changes between online and offline programming. This means that if a parameter is edited using an online command, the change is only displayed in the graphical menu (and thus stored in the project) once the edited parameters have been uploaded from the device!

Terminal options





From the menu, select **Terminal -> Options...** or click on the  symbol (terminal must be selected). In the **Send** and **Receive** tabs select one of the 3 data formats **ASCII**, **Hex** and **Decimal**. The standard format is **ASCII**.

**Notice!**

If your computer has the **Terminal** font installed, please select this font for the display.

In the **Terminal** tab you also have the option to output the **Line number**, the **Date** and the **Time**.

Terminal content

Use the , , and  symbols to save, open or print the data in the terminal window. Use  to clear the content of the terminal window.

In **Version V01.12** and higher of the **BPS Configuration Tool**, the terminal content is logged automatically in the file **terminal.txt**. This file is stored in the main directory of the BPS Configuration Tool. It may be edited with any text editor.

**Attention!**

If another device is selected, the file content is deleted and the recording starts again.

User-defined commands

By using the  symbol, you can create your own commands or sequences or load previously stored commands. In the window that appears, the following labels mean:

Command name: description of the symbol's command.

Command: actual command sequence.

Click the **Accept** button and the new commands appear in the right third of the terminal window below the permanently defined symbols.

Send file

This feature has been implemented to permit several consecutive sequences to be transmitted to the device. This requires the sequences to be created as a text file first. The text file can then be retrieved under **Terminal -> Send file**.

Boot

For the scanner families BPS 8 and BPS 3x, the firmware may be changed directly with the BPS Configuration Tool. This requires the respective firmware boot file, however. To obtain the file, please get into touch with your respective contact person.

Graphical measurement value monitoring

This view allows the current position of the BPS system to be graphically displayed.

Setting the device-specific interface values

This sets the connection (interface) **from the PC to the device** and not the interface of the device. For service interface operation, the settings here do not need to be edited.

If the connected device is **not** operated via the service protocol:

↳ Use the left mouse button to select the device to be edited.

↳ Right click and select **Communication**. In the **Communication properties** window that opens, carry out the respective changes.

If the settings were changed, the Leuze standard parameters can be reselected by clicking on the  button.

Connector unit MA 8-01

The connector unit MA 8-01 is not relevant for the configuration and is thus not supported in the BPS Configuration Tool.

8.1.3.3 Setting the Parameters

You now have commissioned the BPS 8 and are ready to configure it. Using the parameter options made available by the BPS 8, you can configure the BPS 8 to suit your individual area of application. Information about the various configuration options may be found in chapter 8.1.6, page 52.

To understand what is happening during the parameter setting, chapter 8.1.5 briefly explains the various parameter sets. The setting of the parameters then takes place in the **service** operating mode, which is described in the following chapter.

8.1.4 Service operating mode

Setting the required parameters is carried out in the **service** operating mode. The operating mode **Service** provides the following defined operating parameters on the external RS232 interface, no matter how the BPS 8 is configured for standard operation:

- transfer rate 9600 baud
- no parity
- 8 data bits
- 1 stop bit
- prefix: STX
- postfix: CR, LF

8.1.4.1 Activating the service interface

The service interface may be activated as follows:

- via a "v" command during power-up (initialisation phase).
- via the defined bar code label "**Service**" (see accompanying leaflet) in front of the reading window during power-up (initialisation phase).



Figure 8.5: Barcode label "Service"

8.1.4.2 Connecting the service interface

You can connect a PC or a terminal to the BPS 8 via the serial interface and configure the BPS 8 through this connection. For this, you need a crossed RS 232 connection cable (null modem cable) that provides the connections RxD, TxD and GND. A hardware handshake via RTS, CTS is not supported at the service interface.

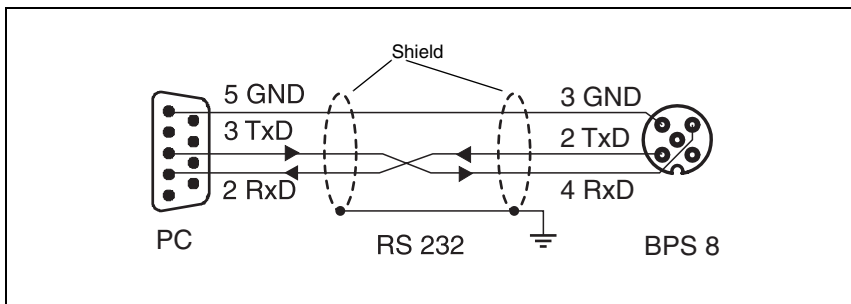

Figure 8.6: Connecting the RS 232 service interface to a PC or terminal

8.1.4.3 Overview of Commands and Parameters

Online commands can be used to send commands directly to the BPS 8 for control and configuration.

For this, the BPS 8 has to be connected to a host or service computer via the serial interface. The commands described can be sent either via the host or the service interface.

General "Online" commands

Command	Description
M+	Activates the measurement.
M-	Deactivate the measurement.
MMS	Controls the data output via the service interface. A single measurement value is output (Single Shot Mode).
MMTyyyy	Controls the data output via the service interface. Measurement values are output cyclically; time must be subsequently specified: yyyy = time specification in ms. Example: MMT0500. Measurement values are output via the service interface in a time interval of 500ms.
MM-	Deactivates the function MMTyyyy If the cyclical output via the service interface is no longer required, the function must be deactivated using the command MM-.
PC20	Resets all parameters in the BPS 8 to Leuze default values.
V	Version query, or puts the device into service mode. This requires a "V" to be transmitted during the initialisation phase of the BPS 8.

8.1.5 Overview of the parameter structure

Using the **BPS Configuration Tool** program, parameters can be changed via the service interface. These parameters are separated into individual tabs in the **Graphical Configuration** menu.

The following tabs are available:

Tab name	Folder contents
Control page 53	• Start mode
	• Stop mode
	• Maximum Polling Interval
Position Logging page 54	• Resolution Host
	• Integration time
	• Preset mode
	• Switch count direction
	• Scaling factor
	• Offset value
	• Min measure length
	• Max measure length
	• Tolerance time
• Fault position output	
Communication page 59	• Baud Rate
	• Data mode
	• Protocol
	• Address
Sensor page 60	• Invert
	• Mode
	• Debounce time
	• Delay on time
	• Pulse duration
	• Delay off time
Switch page 62	• Activation
	• Deactivation
	• Pulse duration

8.1.6 Detailed description of the tabs

**Notice!**

*In the following detailed descriptions of the tabs, you will find in the last column of the tables **cross references (CR) to parameters and input/output data of other tabs** which are directly related to the described parameter. **These cross references must be observed during configuration.***

*Within the tabs, the **parameters** are labelled alphanumerically from **a ... z**.*

Example:

The parameter **a Preset value static** [mm] is activated only if the preset teaching is carried out via switching input **h**.

8.1.6.1 Control

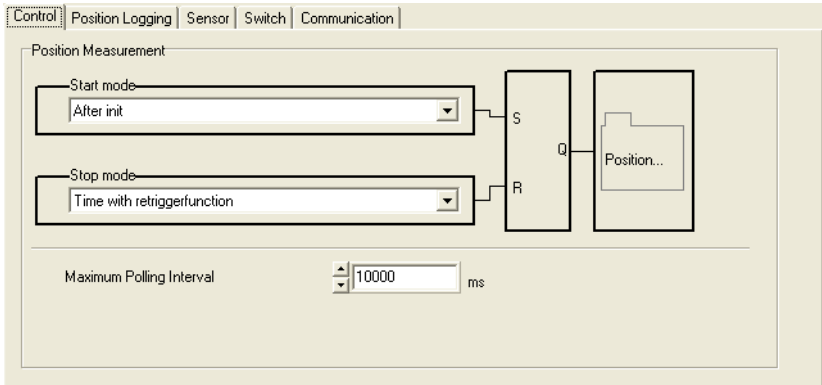

Figure 8.7: Control tab

Description:

The control manages timing of the position calculation by starting and stopping the decoding. Control is performed depending on certain events such as the switching input or time functions. Using parameters, the events which influence the states are determined.

Parameters

Parameter	Description	Value range	Default	Unit	CR
a Start mode	The start mode determines by which event the position measurement is started.	1: After initialisation 2: Via command or switching input	2	-	Sensor h
b Stop mode	The stop mode determines after which event the position measurement is stopped.	2: Time (Polling Interval) 3: Time with retriggering function (polling interval) via command or switching input 4: Via command or switching input (the switching input must be programmed for this purpose)	3	-	Sensor h
c Maximum Polling Interval	Time period after which the scanning beam is switched off if no polling takes place.	0 ... 65'535	10'000	ms	

8.1.6.2 Position Logging

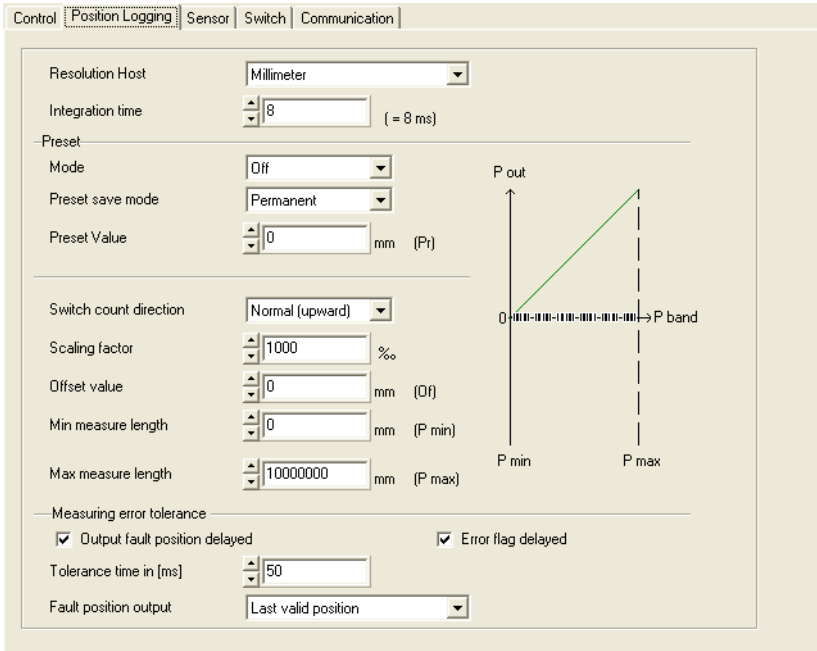

Figure 8.8: Position Logging tab

Description:

The position logging controls all settings that affect the position values.

Parameters

Parameter	Description	Value range	Default	Unit	CR
Resolution Host in [mm]	The parameter specifies the resolution for the position value. The resolution has no effect on - Static preset - Offset.	1: 0.01 2: 0.1 3: 1 4: 10 5: 100 6: 1'000	3	mm	-

With the **Resolution Host** parameter, the resolution for the position values is defined. This parameter also performs a rounding correction (the position value is divided by the defined value range).



Notice!

The resolution only determines the mathematical decimal value and has no effect on the measurement accuracy.

Parameter	Description	Value range	Default	Unit	CR
b Integration time	Number of consecutive scans which are to be used for position determination.	4 ... 32	8	Integration steps	–

The integration depth parameter is used to specify the number of raw position data which is used for integration in order to determine the position value.

Integration depth	Integration time [ms]
4	13.2
5	16.5
6	19.8
7	23.1
8 (default)	26.4
9	29.7
10	33.0
:	:
29	95.7
30	99.0
31	102.3
32	105.6

In order to obtain more exact measurement data while in the static state or for very slow travel speeds, the integration depth can be increased here. If, however, a high integration depth is used for high speeds, the contouring error is increased. With respect to contouring error and exact measurement data, very good results have been obtained using 8 integration steps. Using 8 integration steps, the integration time is 26.4 ms.

Parameter	Description	Value range	Default	Unit	CR
c Preset Mode	Switches the preset function on or off	1: Off 2: On	1	–	–
d Preset save mode	Store data temporarily or permanently.	1: Permanent 2: Temporary	1	–	–
e Preset Value in [mm]	New position value after teach event.	0 ... 10'000'000	0	mm	Sensor h

With this parameter, a preset value can be defined which the BPS 8 outputs following a teach event. A switching input function is defined as a teach event. After reading in the preset, the current position value is replaced by the preset value and the position value is now calculated and output on the basis of the preset. The preset remains stored in the BPS 8 and remains active even following a new start. In order for the BPS 8 to again output the position value without the preset, the Preset mode must be switched off again.



Notice!

To activate this function, the preset mode must be switched on.

The preset value is always entered in units of mm, independent of the resolution setting. The scaling factor has no effect on the static preset value.

Parameter	Description	Value range	Default	Unit	CR
f Switch count direction	Count direction for position calculation.	0: Normal 1: Inverted	0	-	-



Notice!

The BPS 8 is set as follows by default:

The position value is output with **normal** count direction. With the **inverted** count direction, 10'000'000mm minus the position value is output. The **Preset value** and **Offset value** parameters can be used to influence this behaviour.

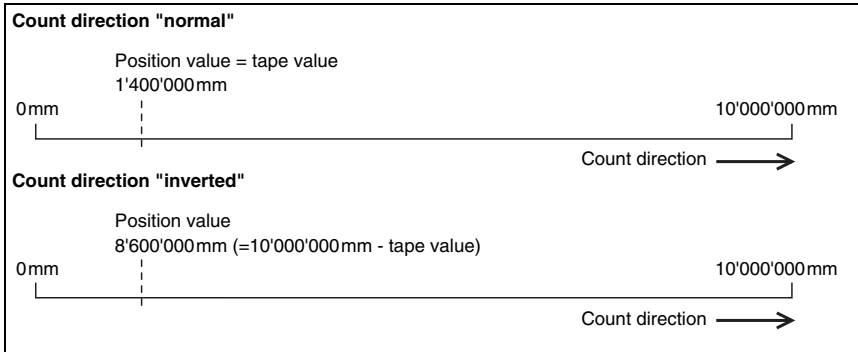

Figure 8.9: Count direction for position calculation

Parameter	Description	Value range	Default	Unit	CR
g Scaling factor in [%]	Scaling factor used to convert the position values.	0 ... 65'535	1.000	‰	–

The scaling function is used to convert the tape values to any unit of measurement. To do this, the tape value is multiplied by the scaling factor.



Notice!

This parameter affects the Offset value. The Preset value parameter is not influenced by the scaling.

Parameter	Description	Value range	Default	Unit	CR
h Offset value in [mm]	Offset value added to tape value.	-10'000'000 ... 10'000'000	0	mm	–

This function adds an offset value to the tape value.



Notice!

If parameter Preset is activated and, as a result, a new value assigned to the tape value, the Offset function no longer affects the position value. The offset is not reactivated until the preset function is cancelled. The offset value is entered in mm. When entering the offset value, the Scaling parameter must be taken into account.

Parameter	Description	Value range	Default	Unit	CR
i Min measure length in [mm]	Minimum permitted measurement length.	0 ... 2'147'483'647	0	mm	Switch d, e
j Max. measure length in [mm]	Maximum permitted measurement length.	0 ... 2'147'483'647	10'000'000	mm	Switch d, e

With this parameter, a working limit on the barcode tape can be defined. The BPS 8 outputs position values within these minimum and maximum limits. Outside of this limit, a position value of zero is output.



Notice!

The signal output can be used to indicate that the measured value is outside of the measurement range. To enable this function, the "outside measurement range" or "inside measurement range" parameter must be activated.

Parameter	Description	Value range	Default	Unit	CR
k Tolerance time in [ms]	Specifies the time for the display of the last position value following an error.	0 ... 65'535	50	ms	–
l Output fault position delayed	Delays the output of an error by the configured tolerance time.	0: No, error delay deactivated 1: Yes, error delay activated	1	–	–
m Error flag delayed	Delays the output of an error in the status byte of the binary protocol by the configured tolerance time.	0: No, error delay deactivated 1: Yes, error delay activated	1	–	–

The measuring error tolerance function is used to configure a time which results in an extended output of the last position value in the event of an error. If the position value changes momentarily to zero, e.g. due to a brief interruption of the scanning beam, soiling of the barcode tape or other short-term disturbances, the BPS 8 transmits the last valid position value.

If the error disappears within the configured time, the control notices nothing. The availability of the system is thereby ensured. No new values are delivered by the BPS 8, however, for a period of time extending up to the configured tolerance time. With the **Output fault position delayed** parameter, an integration error (corresponds to a missing position value) can be signalled immediately or after the tolerance time has elapsed. If the error persists after the tolerance time has elapsed, a position value of zero is output.

Parameter	Description	Value range	Default	Unit	CR
n Fault positions output	In the case of a fault, retain the last position value or output zero.	0: Zero 1: Last valid position	1	–	–

8.1.6.3 Communication

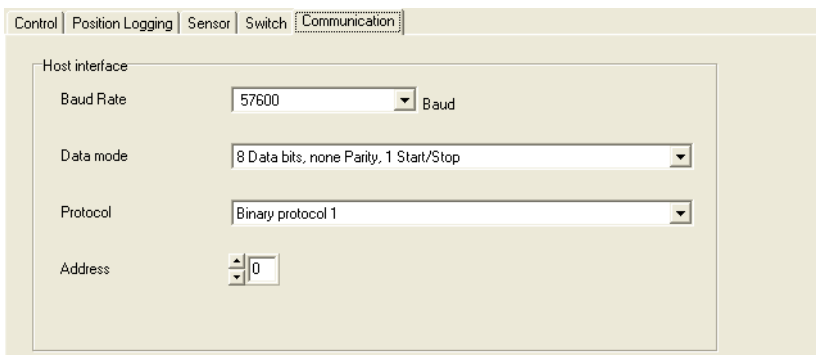

Figure 8.10: Communication tab

Parameters

Parameter	Description	Value range	Default	Unit	CR
a Baud Rate	Baud rate setting.	4: 1200 5: 2400 6: 4800 7: 9600 8: 19200 9: 38400 10: 57600 11: 62500 12: 115200 13: 187500	10	Baud	–
b Data mode	Data mode setting.	1: 7 Data bits, no Parity, 2 Stop bits 2: 7 Data bits, even Parity, 1 Stop bit 3: 7 Data bits, even Parity, 2 Stop bits 4: 7 Data bits, odd Parity, 1 Stop bit 5: 7 Data bits, odd Parity, 2 Stop bits 6: 8 Data bits, no Parity, 1 Stop bit 7: 8 Data bits, no Parity, 2 Stop bits 8: 8 Data bits, even Parity, 1 Stop bit 9: 8 Data bits, even Parity, 2 Stop bits 10: 8 Data bits, odd Parity, 1 Stop bit 11: 8 Data bits, odd Parity, 2 Stop bits 12: 8 Data bits, no Parity, 1 Stop bit + WakeUp bit 13: 9 Data bits, no Parity, 1 Stop bit	6	–	–
c Protocol	Protocol type setting.	0: Binary protocol 1 1: Binary protocol 2 2: Binary protocol 3	0	–	–
d Address	Sets the subscriber address for the RS 485 network.	0: Address 0 1: Address 1 2: Address 2 3: Address 3	0	–	–



Notice!

The 3 different binary protocols are described in a separate chapter (see chapter 9 "Protocol types for position value output").



Notice!

The settings in the communication area apply to the RS 232 interface of the BPS 8 and to the settings of the RS 485 interface of the MA 8-01. **The conversion from RS 232 to RS 485 in the MA 8-01 is implemented entirely in hardware.** The communication settings for the RS 232 interface also apply to the RS 485 for this reason.

8.1.6.4 Switching input

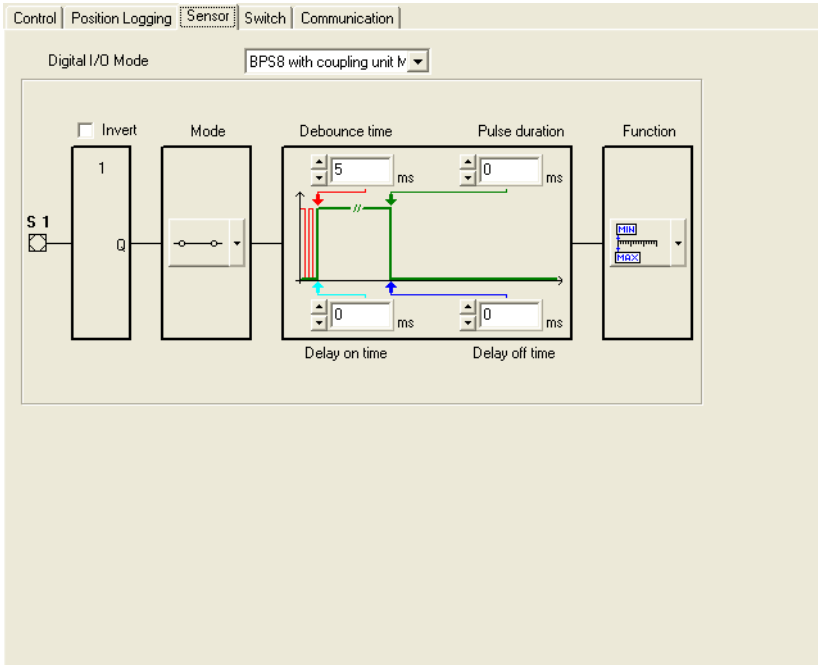

Figure 8.11: Sensor tab

Description:

Within this tab, the mode of operation of the digital switching input is defined.

Parameters

Parameter	Description	Value range	Default	Unit	CR
a Digital I/O Mode	Defines whether the switching input and output are activated via the MA 8-01 or whether only the switching input or only the switching output are activated.	0: Not released 1: BPS 8 with MA 8-01 (switching input + switching output) 2: Switching input 3: Switching output	1	–	–
b Invert	The parameter defines the logic of the pending signal. In case of an inversion, an external HIGH level is interpreted as an internal LOW level.	0: No (active high) 1: Yes (active low)	0	–	–
c Mode	This parameter controls the release of the switching input.	0: Off 1: ON	1	–	–
d Debounce time in [ms]	This parameter defines a debounce time which is implemented in software.	0 ... 255	5	ms	–
e Delay on time in [ms]	The parameter influences the timing during switch-on.	0 ... 65535	0	ms	–
f Pulse duration in [ms]	The parameter defines a minimum time period before the signal is reset.	0 ... 65535	0	ms	–
g Delay off time in [ms]	The parameter defines a time delay for the signal during switch-off.	0 ... 65535	0	ms	–
h Function	The parameter specifies the function which is to be activated or deactivated by a change of state at the switching input.	0: No function	2	–	–
		1: Teach preset			Position Logging e
		2: Start/stop position measurement			Control a
		3: Stop position measurement			Control b



Notice!

The switching input function **Pos. measurement start/stop** in the **Function** parameter means:

- High level at the switching input starts the position measurement.
- Low level at the switching input stops the position measurement.

8.1.6.5 Switching output

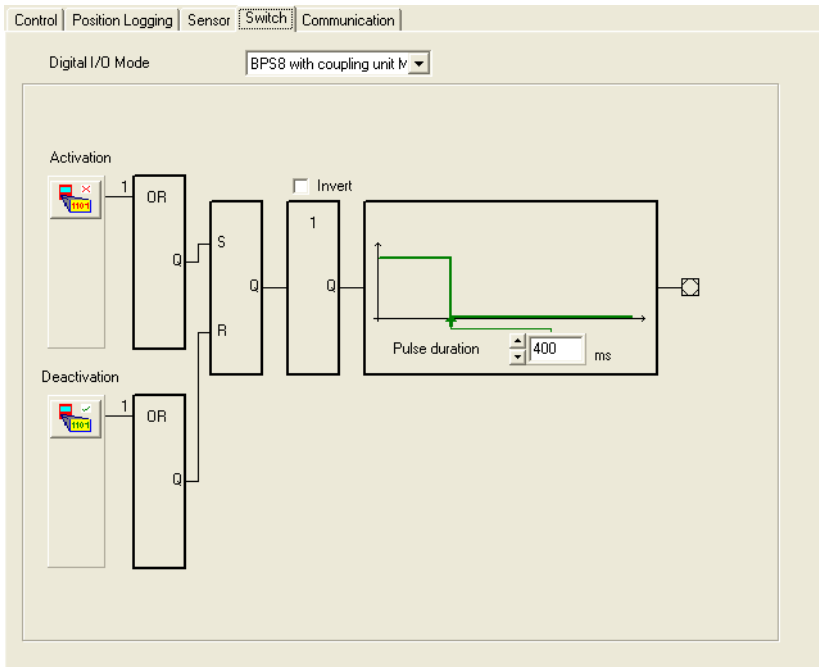

Figure 8.12: Switch tab

Description:

Within this tab, the mode of operation of the digital switching output is defined.

Parameters

Parameter	Description	Value range	Default	Unit	CR
a Digital I/O Mode	Defines whether the switching input and output are activated via the MA 8-01 or whether only the switching input or only the switching output are activated.	0: Not released 1: BPS 8 with MA 8-01 (switching input + switching output) 2: Switching input 3: Switching output	1	–	–
b DC bias level / Invert	The parameter defines the DC bias level of the switching output.	0: LOW (0V) 1: HIGH (+Ub)	0	–	–
c Pulse duration in [ms]	The parameter defines the switch-on time period for the switching output. If the value is 0, the signal is static.	0 ... 1300	400	ms	–
d Activation [EF]	The parameter defines the events which set the switching output: - Outside measurement range - Inside measurement range - Erroneous measurement - Successful measurement	Each 0: Not active 1: Active	0 0 1 0	–	Position Logging i, j Position Logging i, j Position Logging Position Logging
e Deactivation [AF]	The parameter specifies the events which reset the switching output: - Outside measurement range - Inside measurement range - Erroneous measurement - Successful measurement	Each 0: Not active 1: Active	0 0 0 1	–	– Position Logging i, j Position Logging i, j Position Logging Position Logging



Notice!

The events of the switch-on function and switch-off function are both linked to one another with a logical OR.

9 Protocol types for position value output



Notice!

This chapter describes the three binary protocols for communication between host and BPS 8 that can be selected via the communication parameters (see chapter 8.1.6.3).

9.1 Binary protocol type 1



Notice!

With the **BPS Configuration Tool**, the user can individually adapt the binary protocol 1 to the specific requirements of the application. The binary protocols 2 and 3, on the other hand, have a fixed structure and cannot be modified.

9.1.1 Data format

- Baud rate: 57'600 kBd
- Data bits: 8
- Start bits: 1
- Stop bits: 1
- Parity: none



Notice!

Using the **BPS Configuration Tool**, the data format may be configured arbitrarily. The default values are the values shown above.

9.1.2 Telegram structure

9.1.2.1 Query to the BPS 8 (query telegram)

With the help of the **BPS Configuration Tool**, all bits may be configured individually with the following values:

Designation	Type	Description	Function	Value
Request marker info	1 bit	The marker info is requested.	M	1
		The marker info is not requested.		0
Request diagnostic info	1 bit	Diagnostic data is requested.	D	1
		Diagnostic data is not requested.		0
Activate SLEEP mode	1 bit	Laser and polygon wheel motor are switched off and the BPS 8 enters into SLEEP mode ¹⁾ .	SLEEP	1
		Laser and polygon wheel motor are switched on.		0
XOR logic	8 bit	Exclusive-OR logic	XOR	
Address	2 ... x bit	With this bit, the address of the relevant BPS 8 system is transmitted along with the query.	A0 ... Ax	
Bit to zero	1 bit	Bit is permanently set to zero.	0	0
Bit to one	1 bit	Bit is permanently set to one.	1	1
Request individual measurement	1 bit	Request individual measurement (laser on, measurement, laser off).	SINGLE	1
		Individual measurement is not requested.		0

Designation	Type	Description	Function	Value
Request position info	1 bit	Position data is requested.	POS	1
		Position data is not requested.		0
Acknowledge diagnosis	1 bit	Diagnostic data are to be acknowledged.	DQ	1
		Diagnostic data are not to be acknowledged.		0
Check digit	8 bit	Permits a check digit with configurable mode to be stored.	CS	
Prefix	8 bit	Permits a prefix to be selected.	PREFIX	
Postfix	8 bit	Permits a postfix to be selected.	POSTFIX	
Data length	2 ... 8 bit	Permits the following full data length of the information to be transmitted alongside in the protocol.	DL	

- 1) In order to extend the service life of the device, it can be switched to SLEEP mode. In SLEEP mode, the motor and laser are switched off. Diagnosis of the read system cannot be performed.
When reactivating the device, the system takes approx. 5s to boot.



Notice!

The BPS 8 replies to an **Individual measurement** or **Request position info** query with a position response.



Notice!

A0 ... Ax are the address bits. If several BPS 8's operate in one network, an address configuration is required. This can only be done via the **BPS Configuration Tool**.

By default, the control byte is structured as follows:

Bit no.	7	6	5	4	3	2	1	0
Designation	0	0	0	0	POS	SLEEP	M	D
Logic	XOR	XOR	XOR	XOR	XOR	XOR	XOR	XOR

Priority of the bits:

- Priority 1: Diagnostic data
- Priority 2: Marker info
- Priority 3: SLEEP
- Priority 4: Position values



Notice!

It is advisable to set only one control bit for each control byte as the BPS can only answer one query at a time. If several control bits are set, the function with the highest priority is executed.

Bit **POS**: If this bit is set to 1, the position data is output.

Bit **SLEEP**: If this bit is set to 1, the SLEEP mode is activated.

Bit **M**: If this bit is set to 1, the marker information is output.

Bit **D**: If this bit is set to 1, the diagnostic data is sent in response. An indicated error is reset once all diagnostic data has been polled. This is indicated by the status LED changing from red to green.

9.1.2.2 BPS 8 response (response telegram)

With the help of the **BPS Configuration Tool**, all bits can be configured individually and arbitrarily with the following values:

Designation	Type	Description	Function	Value
Error	1 bit	An internal error has occurred.	ERR	1
		No error present.		0
Tape error	1 bit	If there is no barcode tape in the scanning beam, this is signalled by a tape error.	OUT	1
		Barcode tape is in the scanning beam.		0
Marker in memory	1 bit	There is marker information in memory.	MM	1
		There is no marker information in memory.		0
Diagnostic data present	1 bit	Diagnostic data is present in the memory.	D	1
		No diagnostic data present.		0
SLEEP mode	1 bit	Device is in SLEEP mode ¹⁾ .	SLEEP	1
		Device is in positioning mode.		0
Data	16 ... 32 bit	The data are transferred in the control byte, either position data, diagnostic data, marker info or SLEEP response, depending on the query.	DATA	
XOR logic	8 bit	Exclusive-OR logic	XOR	
Data resend	16 ... 32 bit	Depending on the query in the control byte, the data can be retransmitted. This can be the position data, diagnostic data or marker info.	RDATA	
Measurement range exceeded	1 bit	The configured measurement range of 10'000'000mm has been exceeded.	MVE	1
		The configured measurement range of 10'000'000mm has not been exceeded.		0
Measurement range underflow	1 bit	The configured measurement range of 0mm has not been reached.	MVFB	1
		The configured measurement range of 0mm has been exceeded.		0
Range error	1 bit	Outside the configured measurement range.	RANGE	1
		Inside the configured measurement range.		0
Marker detected	1 bit	A marker label has been detected in the scanning beam.	M	1
		No marker label has been detected in the scanning beam.		0
Address	2 ... x bit	The BPS 8 system supplies the pre-configured address.	A0 ... Ax	
Number of labels in the last scan	3 bit	Number of position labels in the last scan.	SCAN-INFO	
Bit to zero	1 bit	Bit is permanently set to zero.	0	0
Bit to one	1 bit	Bit is permanently set to one.	1	1
Sign of position value	1 bit	Calculated position values are negative.	POSH	1
		Calculated position values are positive.		0
State of the switching input	1 bit	Switching input activated.	SI	1
		Switching input deactivated.		0
State of the switching output	1 bit	Switching output activated.	SO	1
		Switching output deactivated.		0
Check digit	8 bit	Permits a check digit with configurable mode to be stored.	CS	
Prefix	8 bit	Permits a prefix to be selected.	PREFIX	
Postfix	8 bit	Permits a postfix to be selected.	POSTFIX	
Data length	2 ... 8 bit	Permits the following full data length of the information to be transmitted alongside in the protocol.	DL	

- 1) In order to extend the service life of the device, it can be switched to SLEEP mode. In SLEEP mode, the motor and laser are switched off. Diagnosis of the read system cannot be performed.

When reactivating the device, the system takes approx. 5s to boot.

By default, the response from the BPS 8 is structured as follows:

Byte no.	Designation	Bit 7	Bit 6	Bit 5	Bit 4	Bit 3	Bit 2	Bit 1	Bit 0
0	Status byte	0	0	0	SLEEP	MM	D	OUT	ERR
1	Data byte 1	P31	P30	P29	P28	P27	P26	P25	P24
2	Data byte 2	P23	P22	P21	P20	P19	P18	P17	P16
3	Data byte 3	P15	P14	P13	P12	P11	P10	P09	P08
4	Data byte 4	P07	P06	P05	P04	P03	P02	P01	P00
5	XOR logic	Exclusive OR logic of bytes 0 to 5							



Notice!

The **P00** data bit corresponds to the **LSB**, the **P31** data bit corresponds to the **MSB**.

Response to marker information

If information consisting of one of the capital letters A / B / C / D / Z and two digits is read, the **MM** bit for the recognition of the marker information is set in the status byte. The **M** control bit can now be used to retrieve the marker info. If the marker info is not requested, the position continues to be output.

The marker information is output as an ASCII hex value in three bytes.

Marker detection:

If there is marker information within the detection range, it is indicated in the status byte.

Bit labelled **MM** in the status byte:

0 = no marker in memory.

1 = marker in memory.

Requesting marker information:

If the respective bit in the control byte is set, the marker label is output as an ASCII hex value on the interface, instead of the position.

Bit labelled **M** in the status byte:

0 = do not send marker info.

1 = send marker info.

Definition of the marker labels:

The following combinations of letters and numbers may be used as marker labels:

First character: A / B / C / D / Z

Second character: digit between 0 ... 9

Third character: digit between 0 ... 9

Structure of the marker label:

The marker label uses code type **Code128 with character set B** as opposed to Code128 with character C for the position barcodes. Code128 with character set B enables the display of all letters and numbers in the ASCII character set.

Using the marker label with positioning (barcode tape):

The marker label must be attached to the tape aligned with the grid of the actual coding. A position code must be visible before and after the marker label.

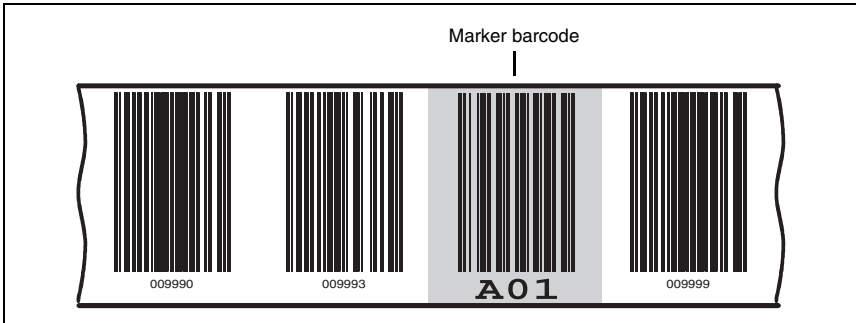

Figure 9.1: System arrangement of marker labels

Using the marker label without positioning (barcode tape):

The marker label must be positioned within the BPS 8's detection range.

Positioning of the marker label:

At any one time, no more than one marker label must be visible in the BPS 8's detection range.

Function sequence if a marker is inside the detection area:

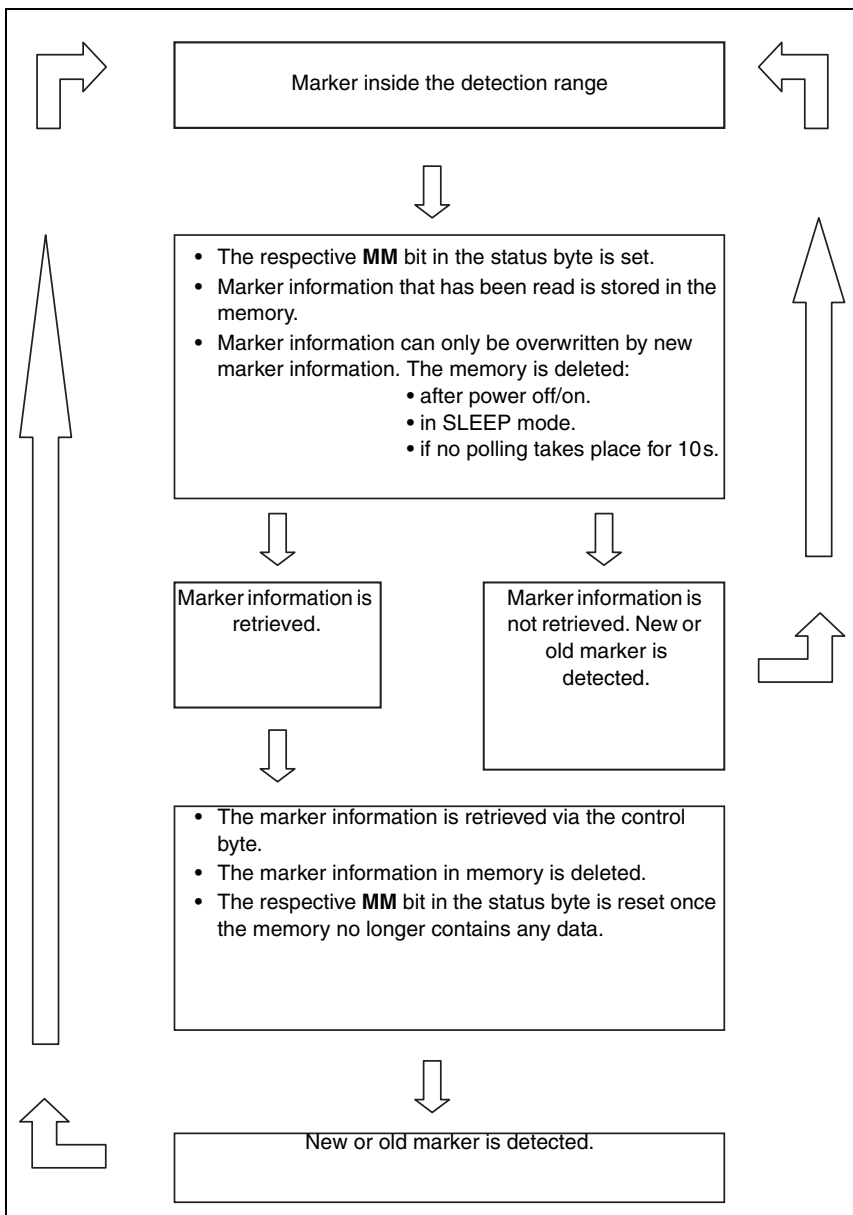

Figure 9.2: Function sequence for marker inside the detection area

This process toggles the data as long as the **MM** bit is set to 1, i.e., as long as the memory contains marker information. The marker info does not depend on the BPS speed or on the control's clock rate.

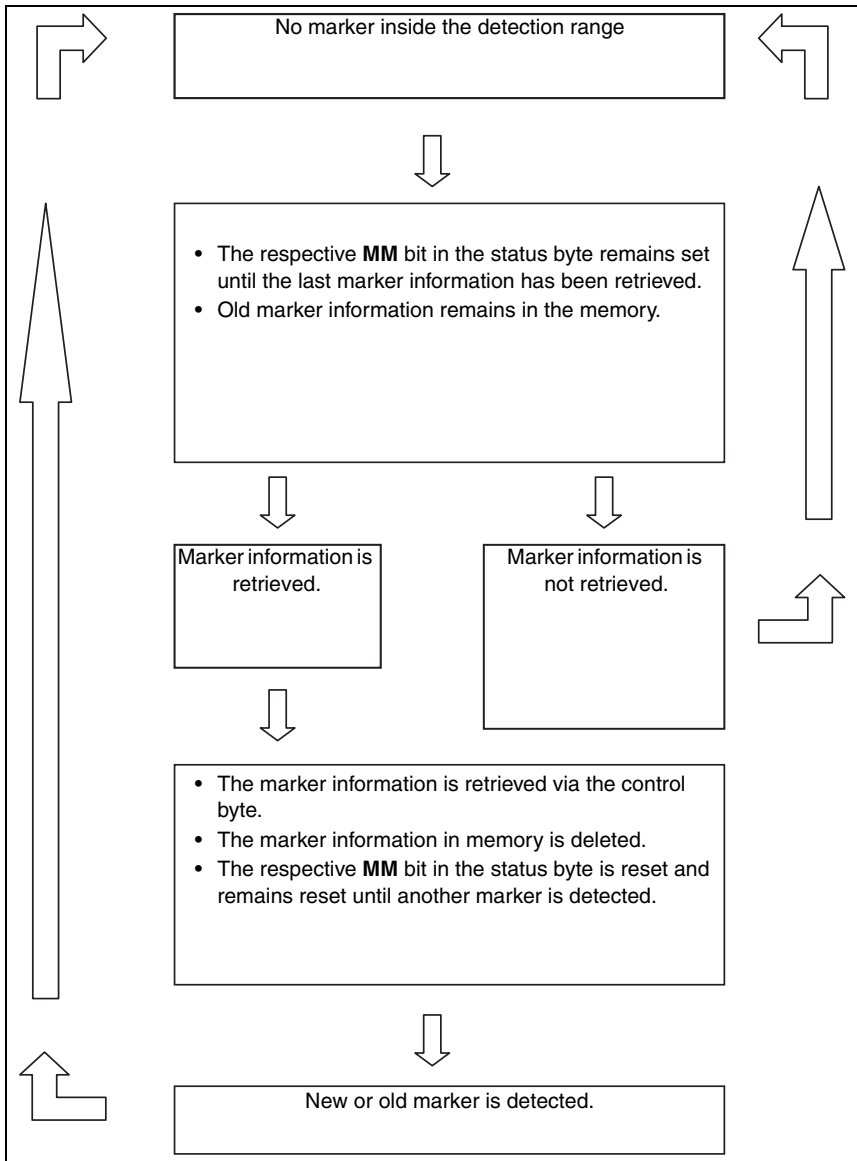

Figure 9.3: Function sequence for no marker inside the detection area

Output of the marker information

Example marker information: **A01**

Data byte 2 = **A** = 41 Hex = 01000001 Bin

Data byte 3 = **0** = 30 Hex = 00110000 Bin

Data byte 4 = **1** = 31 Hex = 00110001 Bin

Byte no.	Designation	Bit 7	Bit 6	Bit 5	Bit 4	Bit 3	Bit 2	Bit 1	Bit 0
0	Status byte	0	0	0	SLEEP	MM	D	OUT	ERR
1	Data byte 1	0	0	0	0	0	0	0	0
2	Data byte 2	0	1	0	0	0	0	0	1
3	Data byte 3	0	0	1	1	0	0	0	0
4	Data byte 4	0	0	1	1	0	0	0	1
5	XOR logic	Exclusive OR logic of bytes 0 to 5							



Notice!

*If there is no marker in the marker memory of the BPS 8 and a marker query is received, **E00** is transmitted as three ASCII characters.*

Answer to diagnostic query

If the diagnostic bit **D** in the status byte is set to 1, diagnostic data is present and may be retrieved.

By setting the respective **D** bit in the control byte (= bit 0), the diagnostic data is retrieved. The diagnostic bit **D** remains set to 1 as long as data is present. Only after the memory for diagnostic data is empty, the bit changes to 0 and the red status LED returns to normal mode.

Just as the marker information, the diagnostic data is transmitted as 3 ASCII characters.

Diagnostic information offered:

The diagnostic data have the following format:

Byte 1 = **E** defines the diagnostic data

Byte 2 = **x** number describing the error.

Byte 3 = **x** number describing the error.

Possible diagnostic data:

100 = software version number of the BPS 8, 1.00 in this example

E01 = interface problem

E02 = motor problem

E03 = laser problem

E04 = internal problem

E05 = position value outside the measurement range

SOS = BPS 8 in SLEEP mode (System Operation Standby/SLEEP)

**Notice!**

If bit 4 **SLEEP** in the control byte is set to 1 and bit 2 **D** in the status byte has the value 1, the BPS 8 is in **SLEEP** mode (laser and polygon wheel motor off). If bit 2 **SLEEP** in the control byte is set to 0, the BPS 8 returns to positioning mode after a boot time of approx. 5s. If polling takes place while the BPS 8 boots and there is no valid position data yet, the error message **tape error** (bit **OUT**) is generated.

Output of the diagnostic data

Example for diagnostic data: **E05**

Data byte 2 = **E** = 45 Hex = 01000101 Bin

Data byte 3 = **0** = 30 Hex = 00110000 Bin

Data byte 4 = **5** = 35 Hex = 00110101 Bin

Byte no.	Designation	Bit 7	Bit 6	Bit 5	Bit 4	Bit 3	Bit 2	Bit 1	Bit 0
0	Status byte	0	0	0	SLEEP	MM	D	OUT	ERR
1	Data byte 1	0	0	0	0	0	0	0	0
2	Data byte 2	0	1	0	0	0	1	0	1
3	Data byte 3	0	0	1	1	0	0	0	0
4	Data byte 4	0	0	1	1	0	1	0	1
5	XOR logic	Exclusive OR logic of bytes 0 to 5							

**Notice!**

If there is a diagnostic query during **SLEEP** mode, **SOS** (System Operation Standby/SLEEP) is transmitted in data bytes 2 to 4.

9.2 Binary protocol type 2



Notice!

With the **BPS Configuration Tool**, the user can individually adapt the binary protocol 1 to the specific requirements of the application. The binary protocols 2 and 3, on the other hand, have a fixed structure and cannot be modified.

9.2.1 Data format

- Baud rate: 62'500 kBaud
- Data bits: 9
- Start bits: 1
- Stop bits: 1
- Parity: none

9.2.2 Telegram structure

9.2.2.1 Query to the BPS 8 (control byte)

Bit no.	8	7	6	5	4	3	2	1	0
Designation	Fixed 1	Fixed 0	Fixed 1	Fixed 1	SLEEP	S-Bit 1	S-Bit 0	A1	A0

Bit	Function	Value	Explanation
0	A0	0	All read heads are occupied with address 0. The address can only be changed via the BPS Configuration Tool.
1	A1	0	Position data is sent.
2	S-Bit 0	1	The marker information is sent.
3	S-Bit 1	0	Position data is sent.
		1	Diagnostic data is sent.
4	SLEEP	0	Polygon wheel motor is switched on.
		1	Polygon wheel motor is switched off (SLEEP mode ¹⁾).
5	Fixed 1	1	No function, permanently set to 1.
6	Fixed 1	1	No function, permanently set to 1.
7	Fixed 0	0	No function, permanently set to 0.
8	Fixed 1	1	No function, permanently set to 1.

- 1) In order to extend the service life of the device, it can be switched to SLEEP mode. In SLEEP mode, the motor and laser are switched off. Diagnosis of the read system cannot be performed.
When reactivating the device, the system takes approx. 5s to boot.

Priority of the bits

- Priority 1: Diagnostic data
- Priority 2: Marker info
- Priority 3: SLEEP
- Priority 3: Position values

**Notice!**

It is advisable to set only one control bit for each control byte as the BPS can only answer one query at a time. If several control bits are set, the function with the highest priority is executed.

**Notice!**

***A0** and **A1** are the address bits. If several BPS 8's operate in one network, an address configuration is required.*

Bit S-Bit 0: If this bit is set to 1, the marker information is output.

Bit S-Bit 1: If this bit is set to 1, the diagnostic data is sent in response. Any error indicated is reset. This may be recognised by the status LED changing from red to green.

Bit SLEEP: This bit is used to activate the SLEEP mode.

9.2.2.2 Response from the BPS 8

Data content:

Byte no.	Designation	Bit 8	Bit 7	Bit 6	Bit 5	Bit 4	Bit 3	Bit 2	Bit 1	Bit 0
0	Status byte	NU	D	M	A1	A0	QT1	QTO	OUT	ERR
1	Data byte 1	0	P23	P22	P21	P20	P19	P18	P17	P16
2	Data byte 2	0	P15	P14	P13	P12	P11	P10	P09	P08
3	Data byte 3	0	P07	P06	P05	P04	P03	P02	P01	P00
4	XOR logic	Exclusive OR logic of bytes 0 to 3								
5	Repetition of data byte 1	0	P23	P22	P21	P20	P19	P18	P17	P16
6	Repetition of data byte 2	0	P15	P14	P13	P12	P11	P10	P09	P08
7	Repetition of data byte 3	0	P07	P06	P05	P04	P03	P02	P01	P00

Description of the status byte

Byte	Bit	Function	Value	Explanation
0	0	ERR	0	No errors occurred during the calculation of the position value.
			1	During the calculation of the position value, (int.) errors occurred.
	1	OUT	0	Scanning beam is positioned on the bar code tape.
			1	Scanning beam is positioned outside of the bar code tape.
	2	QTO		Read quality.
	3	QT1		Read quality.
	4	A0		Address.
	5	A1		Address.
	6	M	0	No marker information present.
1			Marker information present.	
7	D	0	No diagnostic data present.	
		1	Diagnostic data present.	
8	NU	0	No meaning - bit is permanently set to 0.	
1 ... 3	0 ... 8	POS	--	Position value, binary encoded.
4	0 ... 8	XOR	--	Block check digit, exclusive-OR logic of byte 0 to byte 3.
5 ... 7	0 ... 8	WPOS	--	Repetition of position value, binary encoded.



Notice!

At a resolution of 1 mm and with 24 position bits, a maximum position of up to 16'777'215mm can be transmitted.



Notice!

The **P00** data bit corresponds to the **LSB**, the **P23** data bit corresponds to the **MSB**.

Response to marker information

If information consisting of one of the capital letters A / B / C / D / Z and two digits is read, the **M** bit for the recognition of the marker information is set in the status byte. The **S-Bit 0** control bit can now be used to retrieve the marker information. If the marker info is not requested, the position continues to be output.

The marker information is output as an ASCII hex value in three bytes.

Marker detection:

If there is marker information in the marker memory, it is indicated in the status byte.

Bit 6 labelled **M** in the status byte:

0 = no marker in marker memory. Data have been polled and retrieved.

1 = marker in marker memory.

Requesting marker information:

If the respective bit in the control byte is set, the marker label is output as an ASCII hex value on the interface, instead of the position.

Bit 2 labelled **S-Bit 0** in the control byte:

0 = do not send marker information.

1 = send marker information.

Definition of the marker labels:

The following combinations of letters and numbers may be used as marker labels:

First character: A / B / C / D / Z

Second character: digit between 0 ... 9

Third character: digit between 0 ... 9

Structure of the marker label:

The marker label uses code type **Code128 with character set B** as opposed to Code128 with character C for the position barcodes. Code128 with character set B enables the display of all letters and numbers in the ASCII character set.

Using the marker label with positioning (barcode tape):

The marker label must be attached to the tape aligned with the grid of the actual coding. A position code must be visible before and after the marker label.



Figure 9.4: System arrangement of marker labels

Using the marker label without positioning (barcode tapes):

The marker label must be positioned within the BPS 8's detection range.

Positioning of the marker label:

At any one time, no more than one marker label must be visible in the BPS 8's detection range.

Function sequence if a marker is inside the detection area:

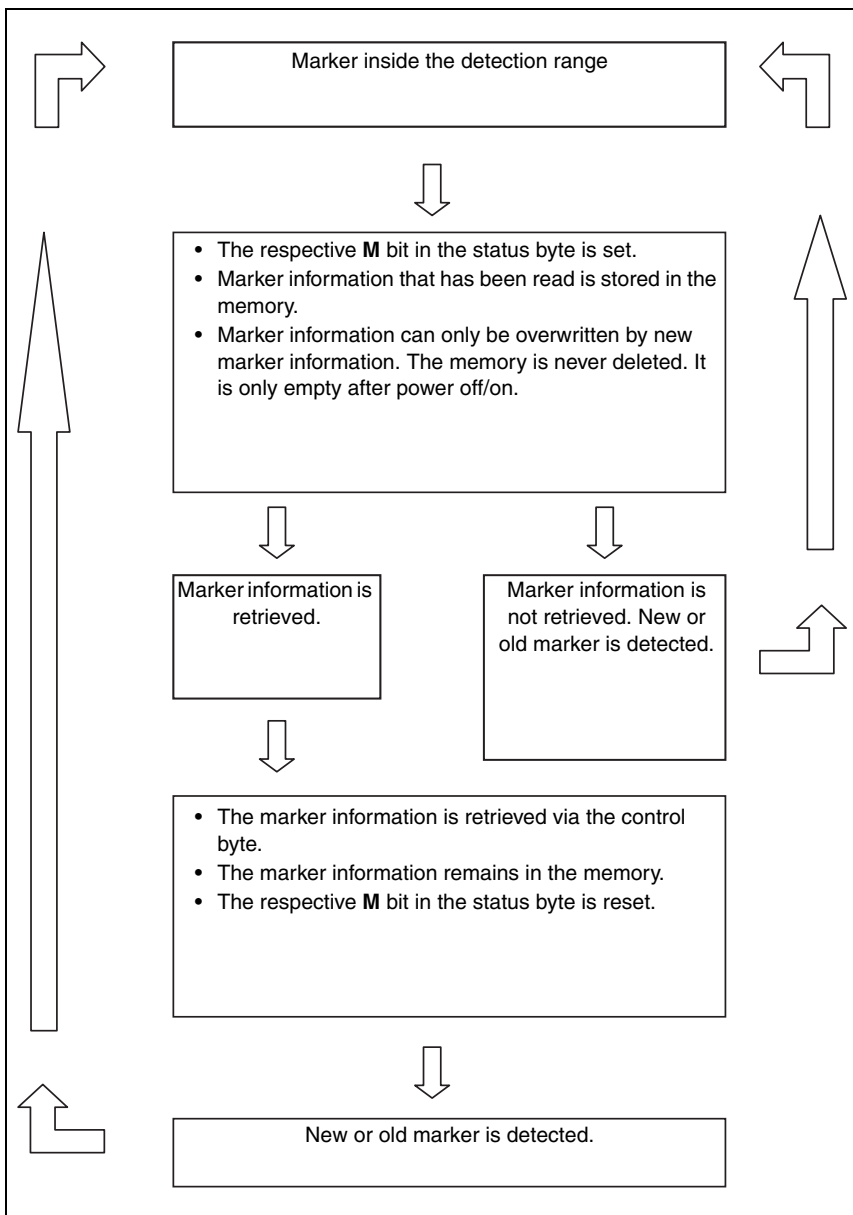

Figure 9.5: Function sequence for marker inside the detection area

This process toggles the **M** bit in the status byte as long as there is a marker in the detection range. The marker info does not depend on the BPS speed or on the control's clock rate.

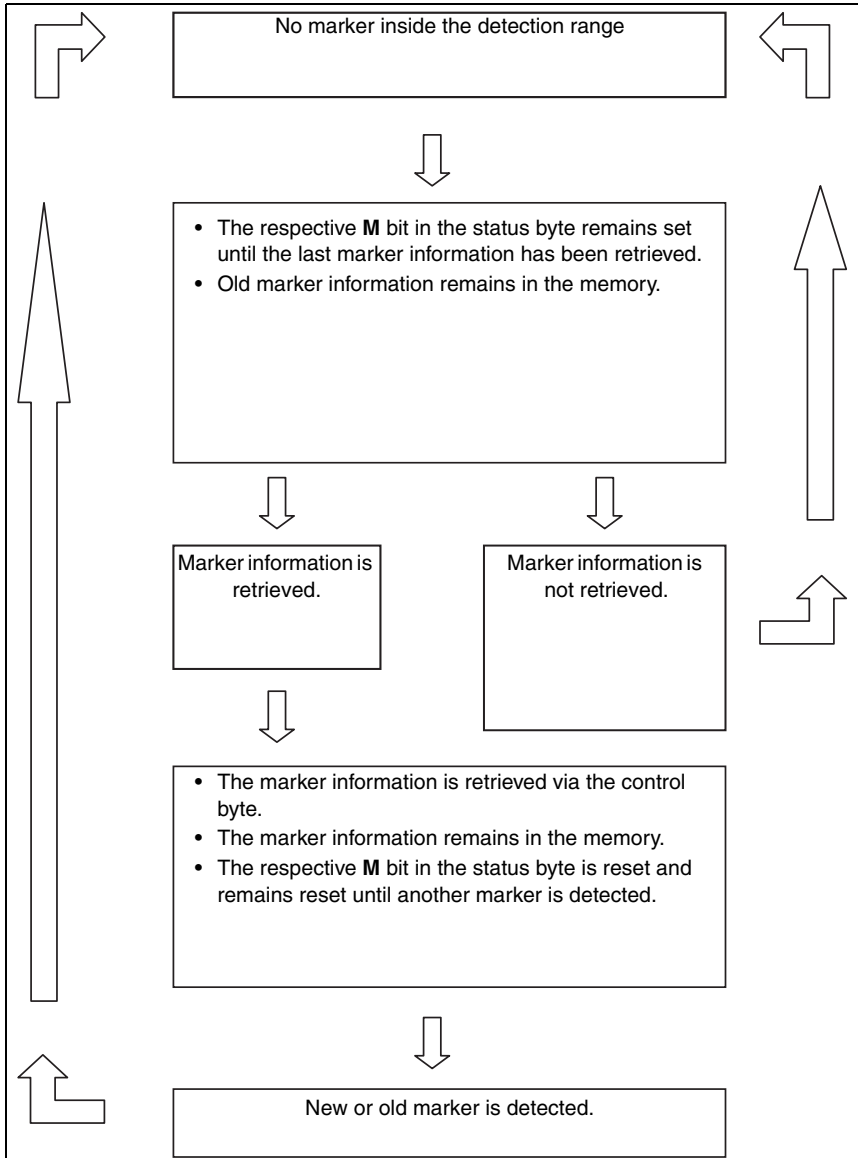

Figure 9.6: Function sequence for no marker inside the detection area

Output of the marker information

Example marker information: **A01**

Data byte 1 = **A** = 41 Hex = 00100001 Bin

Data byte 2 = **0** = 30 Hex = 000110000 Bin

Data byte 3 = **1** = 31 Hex = 000110001 Bin

Byte no.	Designation	Bit 8	Bit 7	Bit 6	Bit 5	Bit 4	Bit 3	Bit 2	Bit 1	Bit 0
0	Status byte 1	NU	D	M	A1	A0	QT1	QT0	OUT	ERR
1	Data byte 1	0	0	1	0	0	0	0	0	1
2	Data byte 2	0	0	0	1	1	0	0	0	0
3	Data byte 3	0	0	0	1	1	0	0	0	1
4	XOR logic	Exclusive OR logic of bytes 0 to 3								
5	Repetition of data byte 1	0	0	1	0	0	0	0	0	1
6	Repetition of data byte 2	0	0	0	1	1	0	0	0	0
7	Repetition of data byte 3	0	0	0	1	1	0	0	0	1

Answer to diagnostic query

If the diagnostic bit **D** in the status byte is set to 1, diagnostic data is present and may be retrieved.

By setting the respective **S-Bit 1** bit in the control byte (= bit 3), the diagnostic data is retrieved. The diagnostic bit **D** remains set to 1 as long as data is present. Only after the memory for diagnostic data is empty, the bit changes to 0 and the red status LED returns to normal mode.

Just as the marker information, the diagnostic data is transmitted as 3 ASCII characters.

Diagnostic information offered:

The diagnostic data have the following format:

Byte 1 = **E** defines the diagnostic data

Byte 2 = **x** number describing the error.

Byte 3 = **x** number describing the error.

Possible diagnostic data:

100 = software version number of the BPS 8, 1.00 in this example

E01 = interface problem

E02 = motor problem

E03 = laser problem

E04 = internal problem

E05 = position value outside the measurement range

SOS = BPS 8 in SLEEP mode (System Operation Standby/SLEEP)

**Notice!**

If bit 2 **SLEEP** in the control byte is set to 1 and bit 7 **D** in the status byte has the value 1, the BPS 8 is in **SLEEP** mode (laser and polygon wheel motor off). If bit 4 **SLEEP** in the control byte is set to 0, the BPS 8 returns to positioning mode after a boot time of approx. 5s. If polling takes place while the BPS 8 boots and there is no valid position data yet, the error message **tape error** (bit **OUT**) is generated.

Output of the diagnostic data

Example for diagnostic data: **E05**

Data byte 1 = **E** = 45 Hex = 001000101 Bin

Data byte 2 = **0** = 30 Hex = 000110000 Bin

Data byte 3 = **5** = 35 Hex = 000110101 Bin

Byte no.	Designation	Bit 8	Bit 7	Bit 6	Bit 5	Bit 4	Bit 3	Bit 2	Bit 1	Bit 0
0	Status byte 1	NU	D	M	A1	A0	QT1	QT0	OUT	ERR
1	Data byte 1	0	0	1	0	0	0	1	0	1
2	Data byte 2	0	0	0	1	1	0	0	0	0
3	Data byte 3	0	0	0	1	1	0	1	0	1
4	XOR logic	Exclusive OR logic of bytes 0 to 5								
5	Repetition of data byte 1	0	0	1	0	0	0	1	0	1
6	Repetition of data byte 2	0	0	0	1	1	0	0	0	0
7	Repetition of data byte 3	0	0	0	1	1	0	1	0	1

**Notice!**

If there is a diagnostic query during **SLEEP** mode, **SOS** (System Operation Standby/**SLEEP**) is transmitted in data bytes 1 to 3.

9.3 Binary protocol type 3



Notice!

With the **BPS Configuration Tool**, the user can individually adapt the binary protocol 1 to the specific requirements of the application. The binary protocols 2 and 3, on the other hand, have a fixed structure and cannot be modified.

9.3.1 Data format

- Baud rate: 19'200 kBaud
- Data bits: 8
- Start bits: 1
- Stop bits: 1
- Parity: even

9.3.2 Telegram structure

9.3.2.1 Query to the BPS 8 (control byte)

Bit no.	7	6	5	4	3	2	1	0
Designation	CMD	F2	F1	F0	0	0	A1	A0

Bit	Function	Value	Explanation
0	A0	0	All read heads are occupied with address 0. The address can only be changed via the BPS Configuration Tool.
1	A1	0	
2	--	0	No function (permanently set to 0).
3	--	0	No function (permanently set to 0).
4	F0	0	Position value request.
		1	Diagnostic data request.
5	F1	0	No function (permanently set to 0).
		1	Polygon wheel motor is switched on.
6	F2	0	Polygon wheel motor is switched on.
		1	Polygon wheel motor is switched off (SLEEP mode ¹⁾).
7	CMD	0	No function.
		1	Byte information is evaluated as a control byte.

- 1) In order to extend the service life of the device, it can be switched to SLEEP mode. In SLEEP mode, the motor and laser are switched off. Diagnosis of the read system cannot be performed.
When reactivating the device, the system takes approx. 5s to boot. It reports after this time with a message "System ready".



Notice!

A0 and **A1** are the address bits. If several BPS 8's operate in one network, an address configuration is required.



Notice!

If the **F0** bit is set to 1, the diagnostic data are sent in response. Any error indicated is reset. This may be recognised by the status LED changing from red to green.

Priority of the bits

- Priority 1: Diagnostic data
- Priority 2: Position values
- Priority 3: SLEEP

**Notice!**

It is advisable to set only one control bit for each control byte as the BPS can only answer one query at a time. If several control bits are set, the function with the highest priority is executed.

9.3.2.2 Response from the BPS 8

Data content:

Byte no.	Designation	Bit 7	Bit 6	Bit 5	Bit 4	Bit 3	Bit 2	Bit 1	Bit 0
0	Status byte	0	SLEEP	A1	A0	CALC	DB	OUT	ERR
1	Data byte	0	P20	P19	P18	P17	P16	P15	P14
2	Data byte	0	P13	P12	P11	P10	P09	P08	P07
3	Data byte	0	P06	P05	P04	P03	P02	P01	P00
4	XOR logic	Exclusive OR logic of bytes 1 to 4							

Description of the status byte

Byte	Bit	Function	Value	Explanation
0	0	ERR	0	No errors occurred during the calculation of the position value.
			1	Errors occurred during the calculation of the position value.
	1	OUT	0	Scanning beam is positioned on the bar code tape.
			1	Scanning beam is positioned outside of the bar code tape.
	2	DB	0	No diagnostic response.
			1	Diagnostic response.
	3	CALC	0	Telegram-specific.
			1	Telegram-specific.
	4	A0	--	No function.
	5	A1	--	No function.
6	SLEEP	0	Read head active.	
		1	Read head in SLEEP mode	
7	NU	0	No meaning - bit is permanently set to 0.	
1 ... 3	0 ... 6	POS	--	Position value, binary encoded
4	0 ... 7	XOR	--	Block check digit, exclusive-OR logic of byte 1 to byte 4.

**Notice!**

At a resolution of 1 mm and with 21 position bits, a maximum position of up to 2'097'151 mm can be transmitted.

**Notice!**

The **P00** data bit corresponds to the **LSB**, the **P20** data bit corresponds to the **MSB**.



Notice!

In the response to a position query, the bits **CALC**, **DB** and **SLEEP** are set as follows:

- **CALC** = 1
- **DB** = 0
- **SLEEP** = 0

Answer to diagnostic query

If the diagnostic bit **DB** in the status byte is set to 1, the data in the data bytes correspond to the diagnostic data.

By setting the respective **F0** bit in the control byte (= bit 3), the diagnostic data is retrieved. The diagnostic data is transmitted as 3 ASCII characters.

Byte no.	Designation	Bit 7	Bit 6	Bit 5	Bit 4	Bit 3	Bit 2	Bit 1	Bit 0
0	Status byte	0	SLEEP	A1	A0	CALC	DB	OUT	ERR
1	Data byte	0	P20	P19	P18	P17	P16	P15	P14
2	Data byte	0	P13	P12	P11	P10	P09	P08	P07
3	Data byte	0	P06	P05	P04	P03	P02	P01	P00
4	XOR logic	Exclusive OR logic of bytes 1 to 4							



Notice!

If bit 2 **DB** is set to 1, diagnostic data is present. In the response to a diagnostic query, the bits **CALC**, **DB** and **SLEEP** are set as follows:

- **CALC** = 1
- **DB** = 1
- **SLEEP** = 0

Diagnostic information offered:

The diagnostic data have the following format:

- Byte 1 = **E** defines the diagnostic data
- Byte 2 = **x** number describing the error.
- Byte 3 = **x** number describing the error.

Possible diagnostic data:

- 100** = software version number of the BPS 8, 1.00 in this example
- E01** = interface problem
- E02** = motor problem
- E03** = laser problem
- E04** = internal problem
- E05** = position value outside the measurement range

Response to sleep mode

Byte no.	Designation	Bit 7	Bit 6	Bit 5	Bit 4	Bit 3	Bit 2	Bit 1	Bit 0
0	Status byte	0	SLEEP	A1	A0	CALC	DB	OUT	ERR
1	Data byte	0	P20	P19	P18	P17	P16	P15	P14
2	Data byte	0	P13	P12	P11	P10	P09	P08	P07
3	Data byte	0	P06	P05	P04	P03	P02	P01	P00
4	XOR logic	Exclusive OR logic of bytes 1 to 4							

**Notice!**

If bit 6 **SLEEP** is set to 1, the BPS is in **SLEEP** mode. In a diagnostic response during sleep mode, the bits **CALC**, **DB** and **SLEEP** are set as follows:

- **CALC** = 0
- **DB** = 0
- **SLEEP** = 1

In **SLEEP** mode, the data bits **P00** to **P20** are always 0.

10 Diagnostics and troubleshooting

10.1 General causes of errors

Error	Possible error cause	Measures
Status LED "off"	<ul style="list-style-type: none"> No supply voltage connected to the device. 	<ul style="list-style-type: none"> <input type="checkbox"/> Check supply voltage.
Status LED "flashing red"	<ul style="list-style-type: none"> Warning. 	<ul style="list-style-type: none"> <input type="checkbox"/> Query diagnostic data and carry out the resulting measures.
Status LED "continuous red light"	<ul style="list-style-type: none"> Error, no function possible. 	<ul style="list-style-type: none"> <input type="checkbox"/> Internal device error, send in device
Status LED "flashing orange"	<ul style="list-style-type: none"> Service operation active. 	<ul style="list-style-type: none"> <input type="checkbox"/> Reset service operation using BPS Configuration Tool.
Decode LED "off"	<ul style="list-style-type: none"> Positioning deactivated. 	<ul style="list-style-type: none"> <input type="checkbox"/> Call up position values. <input type="checkbox"/> Deactivate SLEEP mode
Decode LED "continuous red light"	<ul style="list-style-type: none"> Position value invalid (out of tape). 	<ul style="list-style-type: none"> <input type="checkbox"/> Check positioning of barcode tape. <input type="checkbox"/> Change the angle of the scanning beam by tilting the BPS 8. <input type="checkbox"/> Check mounting. <input type="checkbox"/> Clean BPS 8 window.
Decode LED "continuous orange light"	<ul style="list-style-type: none"> Marker label detected. 	<ul style="list-style-type: none"> <input type="checkbox"/> Retrieve marker label.
Position error	<ul style="list-style-type: none"> No barcode tape present. Scanner positioned in total reflection. Scanner not properly mounted. 	<ul style="list-style-type: none"> <input type="checkbox"/> Check positioning of barcode tape. <input type="checkbox"/> Change the angle of the scanning beam by tilting the BPS 8. <input type="checkbox"/> Check mounting. <input type="checkbox"/> Clean BPS 8 window.

10.2 Error on interface

Error	Possible error cause	Measures
No communication via RS 232/RS 485	<ul style="list-style-type: none"> Incorrect wiring. Different baud rates. Different protocol settings. 	<ul style="list-style-type: none"> <input type="checkbox"/> Check wiring. <input type="checkbox"/> Check baud rate. <input type="checkbox"/> Check protocol settings.
Sporadic errors on the RS 232-/RS 485 interface	<ul style="list-style-type: none"> Incorrect wiring. Effects due to EMC. Overall network expansion exceeded. 	<ul style="list-style-type: none"> <input type="checkbox"/> Check wiring, in particular the shield of the wiring. <input type="checkbox"/> Check the cable used. <input type="checkbox"/> Check shielding (shield covering in place up to the clamping point). <input type="checkbox"/> Check grounding concept and connection to PE. <input type="checkbox"/> Check max. network expansion as a function of the max. cable lengths.

**Notice!**

Please use **page 85 and page 86 as a master copy** should servicing be required.

Cross the items in the "Measures" column which you have already examined, fill out the following address field and fax both pages together with your service order to the fax number listed below.

Customer data (please complete) Leuze service fax number: +49 7021 573-199

Device type:	
Company:	
Contact partner / department:	
Phone (direct):	
Fax:	
Street / No:	
ZIP code/City:	
Country:	

11 Type overview and accessories

11.1 Type overview: BPS 8

Part No.	Type designation	Remark
50104783	BPS 8 S M 102-01	Beam exit at the front and M12 connector
50104784	BPS 8 S M 100-01	Lateral beam exit and M12 connector

11.2 Accessory: Modular connector unit

Part No.	Type designation	Remark
50104790	MA 8-01	Connector unit for BPS 8 with RS 485 interface, M12 connector

11.3 Accessory: Cables

Part No.	Type designation	Remark
50040763	KB 008-1000 AA	M12 connecting cable BPS 8 - MA 8 one axial socket, one axial plug, 1 m
50040762	KB 008-2000 AA	M12 connecting cable BPS 8 - MA 8 one axial socket, one axial plug, 2 m
50040761	KB 008-3000 AA	M12 connecting cable BPS 8 - MA 8 one axial socket, one axial plug, 3 m
50040760	KB 008-1000 AR	M12 connecting cable BPS 8 - MA 8 one axial socket, one angled plug, 1 m
50040759	KB 008-2000 AR	M12 connecting cable BPS 8 - MA 8 one axial socket, one angled plug, 2 m
50040758	KB 008-3000 AR	M12 connecting cable BPS 8 - MA 8 one axial socket, one angled plug, 3 m
50102975	KB 008-10000A	M12 connection cable BPS 8 or MA 8-01 (Host) axial socket, one open cable end, 10 m
50102973	KB 008-5000A	M12 connection cable BPS 8 or MA 8-01 (Host) axial socket, one open cable end, 5 m
50040757	KB 008-3000A	M12 connection cable BPS 8 or MA 8-01 (Host) axial socket, one open cable end, 3 m
50102976	KB 008-10000R	M12 connection cable BPS 8 or MA 8-01 (Host) angled socket, one open cable end, 10 m
50102974	KB 008-5000R	M12 connection cable BPS 8 or MA 8-01 (Host) angled socket, one open cable end, 5 m
50040756	KB 008-3000R	M12 connection cable BPS 8 or MA 8-01 (Host) angled socket, one open cable end, 3 m
50102971	KB 008-10000 A-S	M12 connection cable MA 8-01 (SW IN/OUT) axial plug, one open cable end, 10 m
50102969	KB 008-5000 A-S	M12 connection cable MA 8-01 (SW IN/OUT) axial plug, one open cable end, 5 m
50101941	KB 008-3000 A-S	M12 connection cable MA 8-01 (SW IN/OUT) axial plug, one open cable end, 3 m
50102972	KB 008-10000 R-S	M12 connection cable MA 8-01 (SW IN/OUT) angled plug, one open cable end, 10 m
50102970	KB 008-5000 R-S	M12 connection cable MA 8-01 (SW IN/OUT) angled plug, one open cable end, 5 m
50101942	KB 008-3000 R-S	M12 connection cable MA 8-01 (SW IN/OUT) angled plug, one open cable end, 3 m
50020502	KD 095-5	Angled M12 connection socket with screw terminals
50020501	KD 095-5A	Axial M12 connection socket with screw terminals
50040098	KD 01-5-SA	Axial M12 connector for MA 8-01
50101943	KD 01-5-SR	Angled M12 connector for MA 8-01

11.3.1 Contact assignment of PWR IN connection cable

PWR connection cable (5-pin socket, A-coded)			
 <p>M12 socket (A-coded)</p>	Pin	Name	Core colour
	1	VIN	brown
	2	B (N)	white
	3	GND	blue
	4	A (P)	black
	5	FE	grey
	Thread	FE	Shield

Figure 11.1: Contact assignment of KB 008-10000/5000/3000 (A/R)

11.4 Accessory: Configuration software

Part No.	Type designation	Remark
50060298	BPS Configuration Tool	Programming software

11.5 Accessory: Mounting device

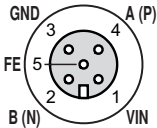
Part No.	Type designation	Remark
50104791	BT 8-01	Mounting device

11.6 Type overview: Barcode tape

Part No.	Type designation	Remark
50104792	BCB 8 010	Barcode tape, 10m length, 47mm height
50104793	BCB 8 020	Barcode tape, 20m length, 47mm height
50104794	BCB 8 030	Barcode tape, 30m length, 47mm height
50104795	BCB 8 040	Barcode tape, 40m length, 47mm height
50104796	BCB 8 050	Barcode tape, 50m length, 47mm height
50104797	BCB 8 060	Barcode tape, 60m length, 47mm height
50104798	BCB 8 070	Barcode tape, 70m length, 47mm height
50104799	BCB 8 080	Barcode tape, 80m length, 47mm height
50104800	BCB 8 090	Barcode tape, 90m length, 47mm height
50104801	BCB 8 100	Barcode tape, 100m length, 47mm height
50104802	BCB 8 110	Barcode tape, 110m length, 47mm height
50104803	BCB 8 120	Barcode tape, 120m length, 47mm height
50104804	BCB 8 130	Barcode tape, 130m length, 47mm height
50104805	BCB 8 140	Barcode tape, 140m length, 47mm height
50104806	BCB 8 150	Barcode tape, 150m length, 47mm height
50104807	BCB 8 special length 47mm high	Barcode tape with special length, 47mm height
50104808	BCB 8 special length 30mm high	Barcode tape with special length, 30mm height
50104809	BCB 8 special length 25mm high	Barcode tape with special length, 25mm height

12 Maintenance

12.1 General Maintenance Information

Usually, the BPS 8 does not require any maintenance by the operator.

In the event of dust build-up, clean the optical window with a soft cloth; use a cleaning agent (commercially available glass cleaner) if necessary.

Also check the barcode tape for possible soiling.



Attention!

Do not use solvents and cleaning agents containing acetone. Use of improper cleaning agents can damage the optical window.

12.2 Repairs, servicing

Repairs to the device must only be carried out by the manufacturer.

↳ *Contact your Leuze distributor or service organisation should repairs be required. The addresses can be found on the inside of the cover and on the back.*



Notice!

When sending devices to Leuze electronic for repair, please provide an accurate description of the error.

12.3 Disassembling, packing, disposing

Repacking

For later re-use, the device is to be packed so that it is protected.



Notice!

Electrical scrap is a special waste product! Observe the locally applicable regulations regarding disposal of the product.

A

Accessories87
 Cable87
 Configuration software88
 Connector unit87
 Mounting device88
 Accuracy11
 Address
 RS 48559
 Areas of application5

B

Barcode tape26
 Curves30
 Gaps28
 Length12
 Mounting8, 28
 Repair kit34
 Roll26
 Specifications27
 Type overview88
 Wrapping direction26
 Baud rate59
 Beam exit8, 9, 39
 Binary protocols59
 Binary protocol type 164
 Binary protocol type 273
 Binary protocol type 381
 BPS Configuration Tool18, 43
 Brief manual44
 Brief manual
 BPS Configuration Tool44

C

Cable87
 Chemical resistance27
 Cleaning
 Optical window89
 Cleaning agents89
 Code type31
 Commands50
 Commissioning steps at a glance8
 Communication
 Tab51, 59
 Configuration45
 Configuration software88

Connecting cable87
 Connection15
 BPS 817
 BPS 8 to MA 8-0119
 Interface9
 MA 8-0110, 17
 PWR IN HOST/RS48520
 RS 23217
 RS 48517, 20
 Service interface49
 SW IN/OUT18
 Switching input10, 18, 19
 Switching input/output17
 Switching output10, 18, 19
 Voltage supply9, 17
 Connection assignment
 BPS 817
 MA 8-0116
 Connection cable87
 Connector unit23, 87
 Contouring error55
 Control
 Tab51, 53
 Control barcode31
 Count direction56
 Curves30
 Cut mark28

D

Data format
 Binary protocol 164
 Binary protocol 273
 Binary protocol 381
 Data mode59
 DC bias level63
 Debounce time61
 Declaration of conformity3, 90
 Decode LED85
 Decoding53
 Description of functions4
 Device arrangement8, 9, 39
 Device parameters41
 Diagnostic data72, 80, 83
 Diagnostics71, 79, 83, 85

Dimensioned drawings	
BPS 8 SM 100-01	14
BPS 8 SM 102-01	13
MA 8-01	24
Dirt	28
Disposing	89
Double insulation	15

E

Electrical connection	15
Electromagnetic compatibility	11, 23
EMC	20
EU Declaration of Conformity	90
Extraneous light	28

F

Functional earth	15, 20, 21
------------------	------------

G

Gaps	28
Graphical configuration	45

H

Hysteresis	33
------------	----

I

Installation	
BPS Configuration Tool	43
Integration time	55
Intended use	5
Interface	9
Error	85
Service	49
Inversion	
Switching input	61

L

Laser radiation	6
Laser safety class	11
LED	
States	21
Light source	11

M

Maintenance	89
Marker info	67, 75
Marker labels	67, 76
Maximum polling interval	53
Measurement length	57
Measurement range	57
Measurement value switching	
between 2 barcode tapes	32
Mounting	36
Barcode tape	28
BPS 8	36
Mounting device	37
Mounting location	39
Outdoors	40
Mounting device	37, 88
MVS	32

N

Notice signs	6
--------------	---

O

Online commands	50
Operating mode	
Service	48
Operating temperature range	11, 23
Operating voltage	11
Optical window	
Cleaning	89
Order codes	87

P

Packing	89
Parameter	48, 50
Structure	51
Pitch	
Scanning beam	39
Polling interval	53
Position calculation	53
Position error	58, 85
Position logging	54
Tab	51, 54
Position value	
in the case of error	58

Positioning
 Control barcode31
 Power consumption11
 Preset55
 Project44
 Protection class 11, 23
 IP 67 17, 18, 19
 Protective housing40
 Protocol59
 Protocol types64
 Pulse duration61

Q

Quality assurance3

R

Reading field curves22
 Reflections6
 Repair 5, 89
 Repair kit
 Barcode tape34
 Resolution54
 Roll
 Barcode tape26
 Rounding correction54
 RS 232 interface41
 RS 485 interface 20, 41
 Address59
 Termination25

S

Safety notices5
 Safety transformer15
 Scaling factor57
 Sensors18
 Service
 Interface49
 Operating mode48
 Service order86
 Shielding21
 SLEEP mode 73, 81, 84
 Software43
 Solvents89

Specifications 11
 Barcode tape 12, 27
 Connector unit 23
 Electrical data 11, 25
 Environmental data 11
 Measurement data 11
 Mechanical data 11
 Optical data 11
 Start mode 53
 Start-up delay 61
 State
 LEDs 21
 Status LED 85
 Stick-on label 6
 Stop mode 53
 Storage temperature range 11, 23
 Switching
 between 2 barcode tapes 32
 Switching input 17, 18, 19
 Tab 51, 60
 Switching output 17, 18, 19
 Tab 51, 62
 Switch-off delay 61
 Switch-off function 63
 Switch-on function 63
 Symbols 3

T

Tab
 Communication 51, 59
 Control 51, 53
 Position logging 51, 54
 Switching input 51, 60
 Switching output 51, 62
 Tape height 39
 Tape switching 33
 Tearing resistance 27
 Telegram structure
 Binary protocol 1 64
 Binary protocol 2 73
 Binary protocol 3 81
 Terminal 46
 Termination 25
 Thread plug 16
 Tolerance time 58
 Travel speed 55
 Traverse rate 11

Tree structure configuration	45
Troubleshooting	85
Type overview	87
Barcode tape	88

U

User-defined commands	47
---------------------------------	----

V

Voltage supply	9
--------------------------	---

W

Warning notices	7
Weathering resistance	27
Weight	11, 23
Wire length	21
Working range	11
Wrapping direction	26