

Digital flowmeter for continuous flow measurement



- Compact or remote version for DN06 to DN400, PN10
- Displays both flow rate and volume (with two totalizers)
- On site calibration by Teach-In
- Simulation of all output signals

Type 8025 can be combined with...



Type S020
INSERTION fitting



Type 8070
Positive displacement
flowmeter



Type 8030
INLINE flowmeter



Type 2301 (8692/8693)
TopControl System

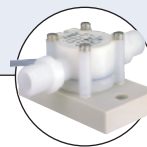

Type 8031
Flow sensor

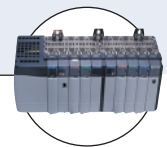

PLC

The flowmeter is specially designed for use in neutral, slightly aggressive, solid-free liquids.

The device is available in different models:

• **The compact flowmeter:**

Compact flowmeter with paddle-wheel sensor: standard output signal or battery powered indicator version without output. (page 2 to 7)

• **The remote transmitter** is available in two versions:

- **Universal transmitter** for panel or wall mounting for connection to any sensors from the market; sensors with open collector output, relay reed output, TTL, CMOS or coil can be operated by this transmitter. (page 8 to 11)

- **Transmitter**, for panel or wall mounting: standard input signal for connection to the Bürkert 8020/8030/8070 flowmeter „Low Power“ version. (page 12 to 14)

Technical data (common to the various versions)

General data

Display	15 x 60 mm, 8-digit LCD, alphanumeric, 15 segments, 9 mm high
Recommended cable	max. 50 m, shielded, 1.5 mm ² max. cross-section

Environment

Height above sea level	max. 2000 m
Relative humidity	≤ 80%, without condensation

Standards, directives and approvals

Standard	EN 61000-6-2, EN 61000-6-3
EMC	
Safety	EN 61010-1
Vibration	EN 60068-2-6
Shock	EN 60068-2-27
Approvals	CE; UL-Recognized for US and Canada (UL61010-1 + CAN/CSA-C22.2 No. 61010-1) 

The compact version

The compact flowmeter is available in two versions:

- standard signal (4...20 mA, frequency)
- battery indicator/totalizer



The flowmeter combines a paddle-wheel flow sensor and an electronic module with a display in an IP65 enclosure.

The electrical connection is provided via a cable plug or two cable glands.

Bürkert designed fitting S020 ensures simple installation of the Bürkert sensor into pipes from DN20 to DN400

General data	
Compatibility	with fittings S020 (see corresponding data sheet)
Materials	
Housing, cover, lid, nut	PC
Front panel foil / Screws	Polyester / Stainless steel
Cable plug or glands	PA
Wetted parts materials	
Fitting	Brass, stainless steel 1.4404/316L, PVC, PP or PVDF
Sensor holder, paddle-wheel	PVDF
Axis and bearing / Seal	Ceramics / FKM (EPDM option)
Electrical connections	Cable plug or cable glands M20 x 1.5 or none (for battery version)
Device data (Fitting S020 + flowmeter)	
Pipe diameter	DN20...DN400
Measuring range	0.3...10 m/s
Fluid temperature with fitting in	
PVC / PP	0...+50°C (+32...+122°F) / 0...+80°C (+32...+176°F)
PVDF, brass or stainless steel	-15...+80°C ¹⁾ (+5...+176°F)
Fluid pressure max.	PN10 (145.1 PSI) (see pressure/temperature diagram on page 5)
Viscosity / Pollution	300 cSt. max. / 1% max.
Measurement deviation	
Teach-In	±1% of Reading ²⁾ (at the teach flow rate value)
Standard K-factor	±2.5% of Reading ²⁾
Linearity	±0.5% of F.S.* ²⁾
Repeatability	±0.4% of Reading ²⁾
Electrical data	
Power supply (V+)	
Standard signal version	12...36 V DC ±10%, filtered and regulated, SELV (safety extra low voltage) circuit with a non dangerous energy level or 115/230 V AC 50/60 Hz (see technical specifications 115/230 V AC)
Battery indicator/totalizer version	4 x 1.5 V DC non-rechargeable alkaline AA batteries, life-time 4 years at 20°C (68°F)
Reversed polarity of DC	protected
Current consumption with sensor (without consumption of pulse output)	≤ 70 mA at 12 V DC - flowmeter with relays ≤ 25 mA at 12 V DC - flowmeter without relay
Output	
Standard signal version	
Signal current	4...20 mA (3-wire with relays; 2-wire without relay) max. loop impedance: 900 Ω at 30 V DC, 600 Ω at 24 V DC, 50 Ω at 12 V DC, 800 Ω with a 115/230 V AC voltage supply
Pulse	Polarized, potential free, 5...36 V DC; 100 mA, protected, line drop at 100 mA: 2.5 V DC
Relay	2 relays, freely configurable, 230 V AC/3 A or 40 V DC/3 A (resistive load)
Battery indicator/totalizer version	None
4...20 mA output uncertainty	±1%
Environment	
Ambient temperature (operation and storage)	-10...+60°C (+32...+140°F) (12...36 V DC version) -10...+50°C (+32...+122°F) (115/230 V AC version) -10...+55°C (+32...+131°F) (batteries version)
Technical specifications 115/230 V AC	
Voltage supply available inside the device	27 V DC regulated, max. current: 125 mA integrated protection: fuse 125 mA temporised power: 3 VA
Specific technical data of UL-recognized products for US and Canada	
Relay output	30 V AC and 42 V peak max./3A or 60 V DC max./1 A
Ambient temperature	0...+40°C (32...+104°F)
Relative humidity	max. 80%, without condensation
Intended for an inner pollution	Pollution degree 2
Installation category	Category I

8025 Flowmeter INSERTION COMPACT



Standards, directives and approvals	
Protection class (according to EN60529)	IP65 with cable plug or gland mounted and tightened or with obturator locked if not used.
Standards and directives Pressure	Complying with article 3 of chap. 3 from 97/23/CE directive**

* F.S. = Full scale (10 m/s)

¹⁾ with Battery version = 100°C (212°F)

²⁾ Under reference conditions i.e. measuring fluid = water, ambient and water temperature = 20°C (68°F), applying the minimum inlet and outlet pipe straights, matched inside pipe dimensions.

** For the 97/23/CE pressure directive, the device can only be used under following conditions (depend on max. pressure, pipe diameter and fluid).

Type of fluid	Conditions
Fluid group 1, chap. 1.3.a	DN25 only
Fluid group 2, chap. 1.3.a	DN ≤ 32, or DN > 32 and PN*DN ≤ 1000
Fluid group 1, chap. 1.3.b	PN*DN ≤ 2000
Fluid group 2, chap. 1.3.b	DN ≤ 200

Operation and display

The device is calibrated by means of the K-factor which is either entered or determined via the Teach-In functions. User adjustments, such as measuring range, engineering units, pulse output and filtering level are carried out via the device operators interface.

The operation is specified according to two or three levels, depending on the flowmeter version:

	Indication in operating mode/display	Parameter definition	Test
Flowmeter	<ul style="list-style-type: none"> flow rate output current main totalizer daily totalizer with reset function 	<ul style="list-style-type: none"> language engineering units K-factor/Teach-In function measuring range 4...20 mA pulse output relay (option) filter reset main totalizer 	<ul style="list-style-type: none"> alteration of basic adjustment (offset, span) frequency test of sensor flow simulation
Battery indicator/totalizer	<ul style="list-style-type: none"> flow rate main totalizer daily totalizer with reset function 	<ul style="list-style-type: none"> language engineering units K-factor/Teach-In function filter reset main totalizer 	<ul style="list-style-type: none"> frequency test of sensor warning and fault messages generating

Description of the navigation keys

To scroll-down the functions or select a digit to be modified
Reading the messages in the information menu²⁾
Auto-scroll the indications²⁾
Battery level display²⁾

To scroll-up the functions or increase a digit

Device status LED²⁾:
see following table



Validation key (value or function)

LED indicating relay 2 status¹⁾

LED indicating relay 1 status¹⁾

¹⁾ Not for battery versions

²⁾ Only for battery versions

Device status LED	Status of the device
Blinking orange	A warning messages is generated in the information menu.
Blinking red	A fault message is generated

Principle of operation



When liquid flows through the pipe, the 4 magnets, inserted in the paddle-wheel set in rotation, produce a measuring signal in the transducer (coil or Hall).

The frequency modulated induced voltage is proportional to the flow velocity of the fluid.

A conversion coefficient (K-factor, available in the instruction manual of the S020 fitting), specific to each pipe (size and material) enables the conversion of this frequency into a flow rate.

The electronic component converts the measured signal into several outputs (according to the flowmeter version) and displays the actual value.

Installation

The 8025 can easily be installed into any Bürkert INSERTION fitting system (S020) by just fixing the main nut.

Minimum straight upstream and downstream distances must be observed. According to the pipe's design, necessary distances can be bigger or use a flow conditioner to obtain the best result. The most important layouts that could lead to turbulence in the flow are shown below, together with the associated prescribed minimum inlet and outlet distances determined according to the standard EN ISO 5167-1.

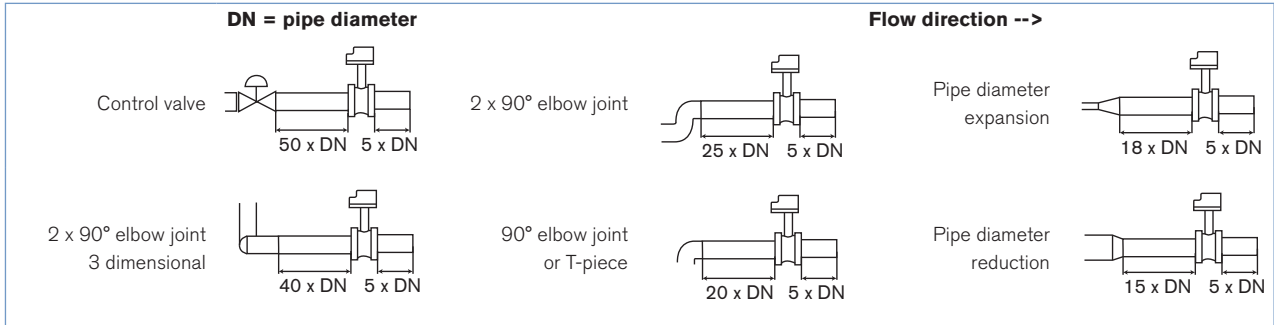

The device can be installed into either horizontal or vertical pipes. Mount the 8025 in these correct ways to obtain an accurate flow measurement.

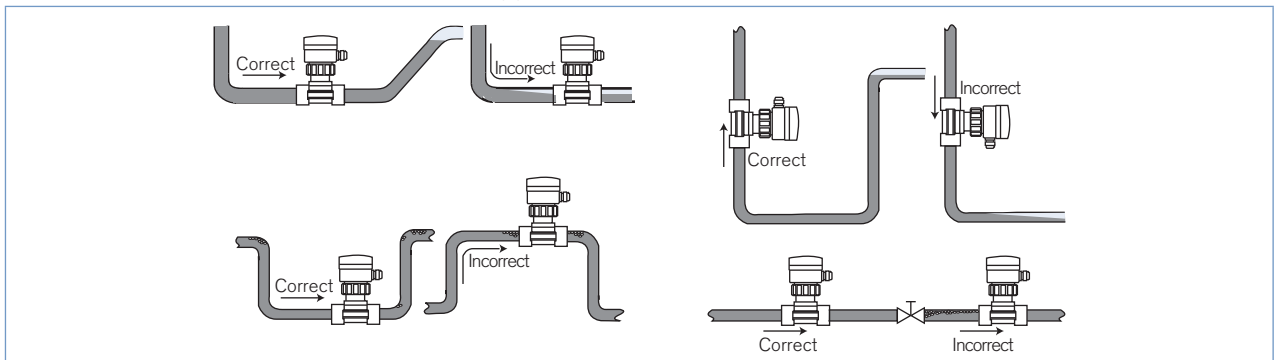

Pressure and temperature ratings must be in accordance to the selected fitting material. The suitable pipe size is selected using the diagram Flow/Velocity/DN. The flowmeter is not designed for gas or steam flow measurement.

Pressure/Temperature diagram

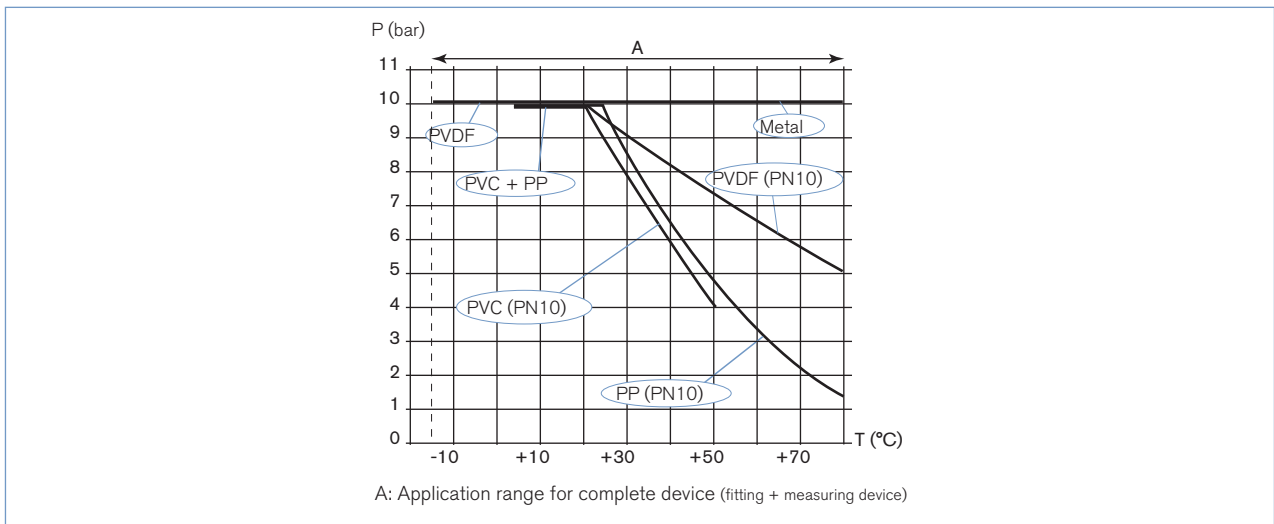
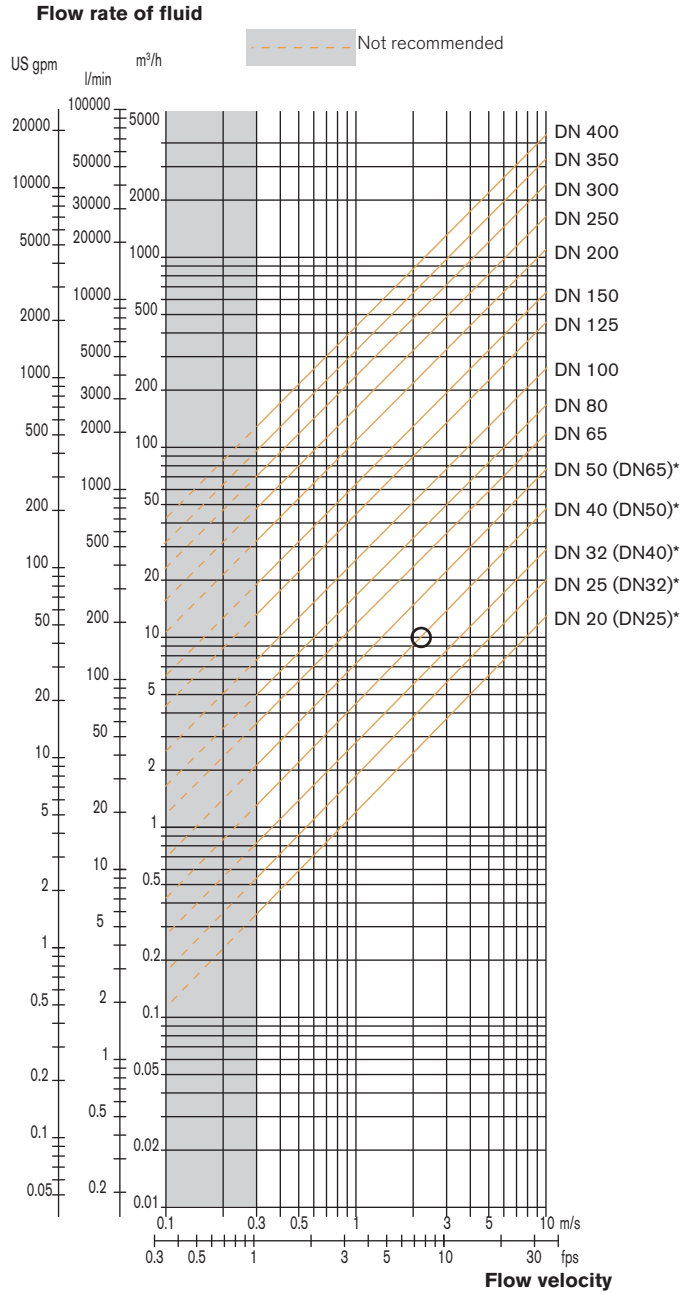

Diagram Flow/Velocity/DN

Example:

- Flow: 10 m³/h
- Ideal flow velocity: 2... 3m/s

For these specifications, the diagram indicates a pipe size of DN40 [or DN50 for (*) mentioned fittings]



- * for following fittings with:**
- external thread acc. to SMS 1145
 - weld end acc. to SMS 3008, BS 4825-1/ASME BPE/DIN 11866 series C or DIN 11850 series 2/DIN 11866 series A/DIN EN 10357 series A
 - Clamp acc. to SMS 3017, BS 4825-3/ASME BPE or DIN 32676 series A

Dimensions [mm]

Note:

The length of the sensor finger depends on the fitting used.

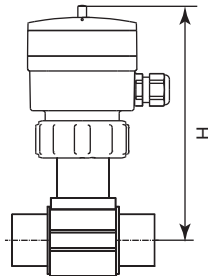
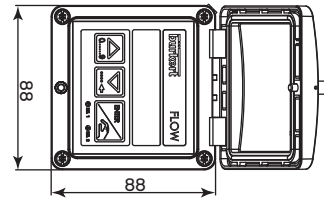
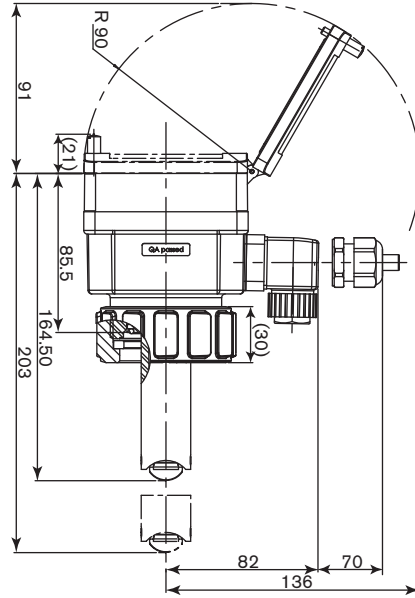

DN	H			
	T-Fitting	Saddle	Plastic spigot	Metal spigot
20	185			
25	185			
32	188			
40	192			
50	198	223		193
65	198	221	206	199
80		226	212	204
100		231	219	214
110		227		
125		234	254	225
150		244	261	236
180		268		
200		280	282	257
250			300	317
300			312	336
350			325	348
400			340	

Ordering chart for compact flowmeter Type 8025

Compact flowmeter or indicator/totalizer with integrated paddle-wheel sensor

A compact flowmeter or indicator/totalizer Type 8025 consists of:

- an INSERTION flowmeter or indicator/totalizer 8025
- an INSERTION fitting Type S020 (DN20 - DN400) (Refer to corresponding data sheet - has to be ordered separately)

Specifica- tions	Voltage supply	Output	Relays	Sensor version	Electrical connection	Item no.
Standard output signal flowmeter, 2 totalizers	12...36 V DC	4...20 mA (2 wires) + pulse	None	Hall, short	Cable plug	418 762
					2 cable glands	418 802
				Hall, long	Cable plug	418 763
					2 cable glands	418 803
	115/230 V AC	4...20 mA (3 wires) + pulse	2	Hall, short	2 cable glands	418 778
					2 cable glands	418 779
				Hall, long	2 cable glands	418 423
					2 cable glands	418 424
Indicator, 2 totalizers	4 x 1.5 V DC AA Batteries	---	None	Coil, short	None	418 403
					Coil, long	418 405
				Coil, long	None	418 431
					2 cable glands	418 432

Note: FKM seal in standard; 1 set including a black EPDM seal for the sensor, an obturator for an M20 x 1.5 cable gland, a 2 x 6 mm multiway seal and a mounting instruction sheet is supplied with each flowmeter.

i Further versions on request



Approvals

FDA, UL-Recognized for US and Canada (UL61010-1 + CAN/CSA-C22.2 No. 61010-1)

Ordering chart - accessories for compact flowmeter Type 8025 (has to be ordered separately)

Specifica- tions	Item no.
Set with 2 cable glands M20 x 1.5 + 2 neoprene flat seals for cable gland or plug + 2 screw-plugs M20 x 1.5 + 2 multiway seals 2 x 6 mm	449 755
Set with 2 reductions M20 x 1.5 /NPT1/2" + 2 neoprene flat seals for cable gland or plug + 2 screw-plugs M20 x 1.5	551 782
Set with 1 stopper for unused cable gland M20 x 1.5 + 1 multiway seal 2 x 6 mm for cable gland + 1 black EPDM seal for the sensor + 1 mounting instruction sheet	551 775
Ring	619 205
Union nut	619 204
Set with 1 green FKM and 1 black EPDM seal	552 111
Cable plug with cable gland (Type 2508)	438 811
Cable plug with NPT1/2" reduction without cable gland (Type 2509)	162 673

Available S020 fitting DN	DN20	DN50	DN65	DN100	DN200	DN350	DN400
T-fitting	Short sensor						
Weld-in socket		Short sensor			Long sensor		
Fusion spigot		Short sensor			Long sensor		
Screw-on S020				Long sensor			
Saddle S020		Long sensor					

The remote Universal version

The **8025 Universal transmitter** can be associated with Bürkert flowmeter 8020, 8030, 8070... or another flow sensor which emits a frequency signal (with pulse output signal).

When connected to a flowmeter, the device makes it possible to switch a solenoid valve, activate an alarm or generate a flow rate proportional frequency, thanks to a digital output and, for some versions, by means of two relay outputs, fully configurable, and to establish a control loop thanks to a 4...20 mA current output.

The 8025 Universal is a flow transmitter with display, available in wall-mounted and panel versions:

The panel version

is made up of an electronics integrated in an open housing with display. The electrical connection is carried out on the terminal blocks of the electronic board



The wall-mounted version

is made up of an electronics integrated in a housing with cover, display. The electrical connection is carried out on the terminal blocks of the electronic board via 3 cable glands.



The device is equipped with a 4...20 mA current output (analogue output, called AO1), a digital output (configured as a pulse output by default, called DO1) and two totalizers.

Some versions are also fitted with two relay outputs (called DO2 and DO3).

The device operates on a 3 wire system and needs a 12...36 V DC or a 115/230 V AC power supply.

Technical data	
General data	
Compatibility	Bürkert flow sensor with frequency output (8020, 8030, 8030HT, 8041, 8031, 8070, 8071) or other sensors with compatible electrical data.
Materials	Housing, cover: PC (panel-mounted version); ABS (wall-mounted version) Front panel foil: Polyester Screws: Stainless steel Cable glands / Cable clips: PA (wall-mounted version) / PA (panel-mounted version)
Electrical connections	Terminals (panel-mounted version) or terminals via gland (wall-mounted version)
Recommended cable	0.2...1.5 mm ² cross-section, shielded cable, 4...8 mm diameter (for the cable glands of the wall-mounted version)
Electrical data	
Power supply (V+)	Panel- and wall-mounted version: 12...36 V DC (max tolerance: -5% or +10% at 12 V DC; ±10% at 36 V DC), filtered and regulated, SELV (safety extra low voltage) circuit with a non dangerous energy level, Wall-mounted version: 115/230 V AC 50/60 Hz (see technical specifications 115/230 V AC)
Reversal polarity of DC	Protected
Current consumption with sensor	(without consumption of current output of the flowmeter) Version with relay: ≤ 90 mA (at 12 V DC); ≤ 45 mA (at 36 V DC); ≤ 55 mA (115/230 V AC) Version without relays: ≤ 60 mA (at 12 V DC); ≤ 30 mA (at 36 V DC); ≤ 40 mA (115/230 V AC)
Transmitter input (from sensor)	Frequency range: 0.6 Hz...2.2 kHz, can be adjusted - max. voltage: 36 V DC Open collector NPN (with 470 Ω or 2.2 kΩ resistance) or PNP, Coil, TTL, CMOS (with 39 kΩ resistance)
Transmitter output (to sensor)	Voltage supply: - with a 12...36 V DC powered transmitter: ■ 10.5... 34.5 V DC [= (V+) - 1.5 V DC], 140 mA max. ■ 0...23.5 V DC [= (V+) - 12.5 V DC], 80 mA max. non regulated ■ 5 V DC, 30 mA max. - with a 115/230 V AC powered transmitter: ■ +27 V DC, 80 mA max. ■ +14.5 V DC [= (V+) - 12.5 V DC] 80 mA max. non regulated ■ 5 V DC, 30 mA max.
Digital outputs	Transistor (DO1) NPN or PNP (wiring dependent), potential free Function: pulse output (by default), configurable 0.6...2200 Hz, 5...36 V DC, 100 mA max., line drop 2.7 V DC at 100 mA duty cycle: ■ > 0.45 if 0.6 < frequency < 300 Hz ■ > 0.4 if 300 < frequency < 1500 Hz ■ < 0.4 if 1500 < frequency < 2200 Hz Galvanic insulation, protected against polarity reversals and short-circuits
	Relay (DO2 and DO3) 2 relays (normally open), freely adjustable (hysteresis by default), 230 V AC/3 A or 40 V DC/3 A (resistive load), max. cutting power of 750 VA (resistive load), life span of min. 100000 cycles
Analogue output	Current (AO1) 4...20 mA, sink or source (wiring dependent), 22 mA to indicate a fault (can be activated); max. loop impedance: 1300 Ω at 36 V DC, 1000 Ω at 30 V DC, 750 Ω at 24 V DC, 300 Ω at 15 V DC, 200 Ω at 12 V DC
4...20 mA output uncertainty	±1%
Technical specifications 115/230 V AC available inside the device	Wall-mounted version: Voltage supply: 27 V DC regulated, Max. current: 250 mA Integrated protection: fuse 250 mA temporised Power: 6 VA

Environment	
Ambient temperature	-10...+60°C (+14...+140°F) (operation and storage)
Standards, directives and approvals	
Protection class	IP65 (panel-mounted and wall-mounted version) device wired and cable glands tightened screwed tight IP20 (panel-mounted version, inside the cabinet)
Approvals	CE; UL-Recognized for US and Canada (UL61010-1 + CAN/CSA-C22.2 No. 61010-1) 
Specific technical data of UL-recognized products for US and Canada	
Relay output	30 V AC and 42 V peak max./3 A or 60 V DC max./1 A
Ambient temperature	0...+40°C (+32...+104°F)
Relative humidity	max. 80 %, without condensation
Intended for an inner pollution	Pollution degree 2, according to EN61010-1
Installation category	Category I, according to UL61010-1

Operation and display

The device is calibrated by means of the K-factor which is either entered or determined via the Teach-In functions. User adjustments, such as measuring range, engineering units, pulse output and filtering level are carried out via the device operators interface.

The operation is specified according to two or three levels, depending on the flowmeter version:

	Indication in operating mode/ display	Parameter definition	Test
Universal flow transmitter	<ul style="list-style-type: none"> ▪ flow rate ▪ output current ▪ main totalizer ▪ daily totalizer with reset function 	<ul style="list-style-type: none"> ▪ language ▪ engineering units ▪ K-factor/Teach-In function ▪ measuring range 4...20 mA ▪ pulse output ▪ relay (option) ▪ filter ▪ reset both totalizers (main and daily) ▪ Low flow "Cut Off" ▪ Brightness of the display (backlight) 	<ul style="list-style-type: none"> ▪ alteration of basic adjustment (offset, span) ▪ frequency test of sensor ▪ flow simulation ▪ warning and fault messages generating

Description of the navigation keys and the status LEDs

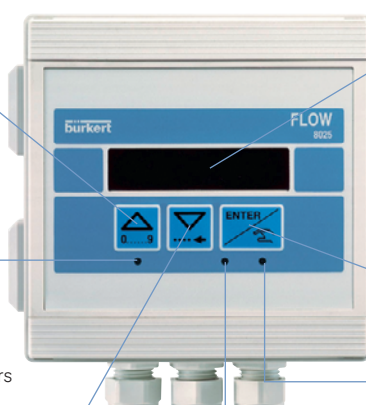

- Scrolling up the parameters within a level or a menu
- increase the figure selected

Device status LED: see following table

- Scrolling down the parameters within a level or a menu
- Selecting the figure on the left
- Reading the messages in the information menu

Large digital display with 8 characters (4 digital characters and 4 alphanumeric characters) indicating:

- the measured flow
- the value of the current output
- the value of the main totalizer
- the value of the daily totalizer

- Selecting the displayed parameters
- Validating the settings

Status LED of relay DO3 (LED ON = contact closed)

Status LED of relay DO2 (LED ON = contact closed)

Device status LED	Status of the device
Green	The device operates correctly.
Orange	A warning messages is generated in the information menu.
Red	A fault message is generated and a 22 mA current is sent on the current output if activated.
Blinking, whatever the colour	A check for the correct behaviour of the outputs is running.

Dimensions [mm]

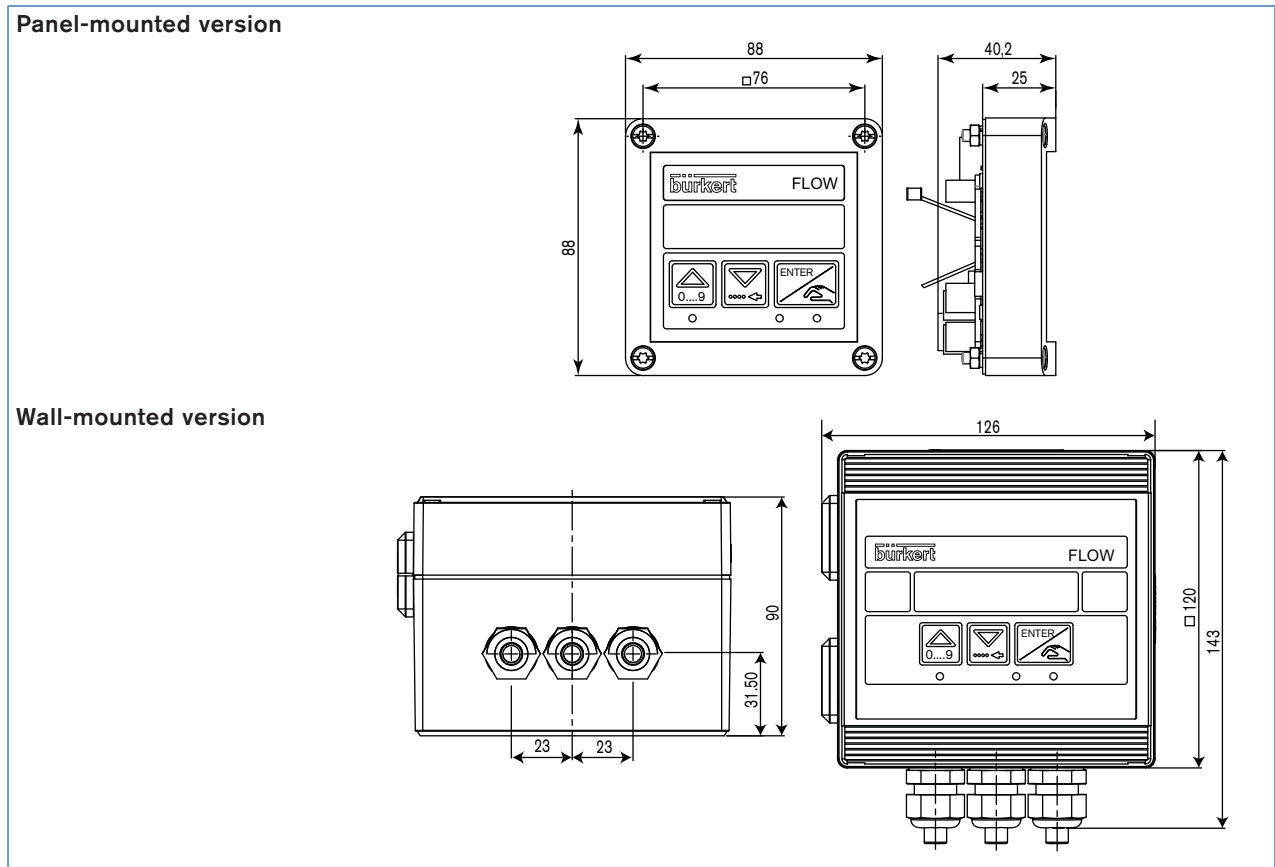

Ordering chart for remote Universal transmitter Type 8025

Remote 8025 Universal transmitter (panel- or wall-mounted) for connection to Bürkert or other sensors.

A complete remote Universal flow transmitter Type 8025 consists of:

- a remote Universal transmitter Type 8025 (wall-mounted or panel-mounted)
- a Bürkert flow sensor* or any (has to be ordered separately)

All these versions have as minimum:

- a 4...20 mA current output (AO1)
- a digital output (DO1)
- two totalizers

Specifications	Voltage supply	Output	Relays	Sensor version	Electrical connection	Item no.
Universal transmitter, panel mounted	12...36 V DC	4...20 mA (3 wires) + pulse	None	see note	Terminal strip	419 538
			2	see note	Terminal strip	419 537
Universal transmitter, panel mounted UL-Recognized for US and Canada	12...36 V DC	4...20 mA (3 wires) + pulse	None	see note	Terminal strip	564 416
			2	see note	Terminal strip	564 417
Universal transmitter, wall-mounted	12...36 V DC	4...20 mA (3 wires) + pulse	None	see note	3 cable glands	419 541
			2	see note	3 cable glands	419 540
	115/230 V AC	4...20 mA (3 wires) + pulse	None	see note	3 cable glands	419 544
			2	see note	3 cable glands	419 543

Ordering chart - accessories for remote Universal transmitter Type 8025 (has to be ordered separately)

Specifications	Item no.
Spare part, panel version	
Mounting set (screws, washer, nuts, cable clips)	554 807
Seal	419 350
Set with 8 FLOW foils	553 191
Spare part, wall version	
Power supply board 115/230 V AC + mounting instruction sheet	555 722

8025 Transmitter REMOTE

The remote version

The 8025 remote transmitter can only be associated with Bürkert flowmeter 8020, 8030, 8070 with sinus or pulse output signal in a "Low Power" version.

When connected to a flowmeter, the device makes it possible to switch a solenoid valve, activate an alarm or generate a flow rate proportional frequency, thanks to a digital output and, for some versions, by means of two relay outputs, fully configurable, and to establish a control loop thanks to a 4...20 mA current output.

The 8025 is a flow transmitter with display, available in wall-mounted and panel versions:

The panel version

is made up of an electronics integrated in an open housing with display. The electrical connection is carried out on the terminal blocks of the electronic board



The wall-mounted version

is made up of an electronics integrated in a housing with cover, display. The electrical connection is carried out on the terminal blocks of the electronic board via 3 cable glands.



The device is equipped with a 4...20 mA current output (analogue output), a digital output (pulse output) and two totalizers.

Some versions are also fitted with two relay outputs.

The device operates on a 2 or 3 wire system and needs a 12...36 V DC or a 115/230 V AC power supply.

Technical data	
General data	
Compatibility	Bürkert flow sensor with frequency output 8020, 8030 or 8070 (pulse "Low Power" version).
Materials	Housing, cover: PC (panel-mounted version); ABS (wall-mounted version) Front panel foil: Polyester Screws: Stainless steel Cable glands / Cable clips: PA (wall-mounted version) / PA (panel-mounted version)
Electrical connections	Terminals (panel-mounted version) or terminals via cable gland (wall-mounted version)
Recommended cable	0.2...1.5 mm ² cross-section, shielded cable, 4...8 mm diameter (for the cable glands of the wall-mounted version)
Electrical data	
Power supply (V+)	Panel-mounted version: 12...36 V DC ±10%, filtered and regulated Wall-mounted version: 12...36 V DC ±10%, filtered and regulated or 115/230 V AC 50/60 Hz (see technical specifications 115/230 V AC)
Reversal polarity of DC	Protected
Current consumption with sensor	(without consumption of pulse output) Version with relay: ≤ 70 mA (at 12 V DC) Version without relays: ≤ 25 mA (at 12 V DC)
Transmitter input (from sensor)	Frequency range: 2.5...400 Hz Pulse "Low Power" (open collector NPN)
Transmitter output (to sensor)	Voltage supply: 10...34 V DC (= (V+) - 2 V DC), Current consumption: max. current available from transmitter: 1 mA
Digital outputs	Pulse: polarized, potential free, 5...36 V DC; 100 mA, protected, line drop at 100 mA: 2.5 V DC Relay: 2 relays, freely configurable, 230 V AC/3 A or 40 V DC/3 A (resistive load)
Analogue output	Current: 4...20 mA (3-wire with relays; 2-wire without relay); max. loop impedance: 900 Ω at 30 V DC, 600 Ω at 24 V DC, 50 Ω at 12 V DC, 800 Ω with a 115/230 V AC voltage supply
4...20 mA output uncertainty	±1%
Technical specifications 115/230 V AC available inside the device	Wall-mounted version: Voltage supply: 27 V DC regulated, Max. current: 250 mA Integrated protection: fuse 250 mA temporised Power: 6 VA
Environment	
Ambient temperature	-10...+60°C (+32...+140°F) (operation and storage)
Standards, directives and approvals	
Protection class	IP65 (panel-mounted and wall-mounted version) device wired and cable glands tightened screwed tight IP20 (panel-mounted version, inside the cabinet)
Approvals	CE; UL-Recognized for US and Canada (UL61010-1 + CAN/CSA-C22.2 No. 61010-1)
Specific technical data of UL-recognized products for US and Canada	
Relay output	30 V AC and 42 V peak max./3 A or 60 V DC max./1 A
Ambient temperature	-10...+60°C (+14...+140°F)
Relative humidity	max. 80 %, without condensation
Intended for an inner pollution	Pollution degree 2, according to EN61010-1
Installation category	Category I, according to UL61010-1

Operation and display

The device is calibrated by means of the K-factor which is either entered or determined via the Teach-In functions. User adjustments, such as measuring range, engineering units, pulse output and filtering level are carried out via the device operators interface.

The operation is specified according to two or three levels, depending on the flowmeter version:

	Indication in operating mode/display	Parameter definition	Test
Flow transmitter	<ul style="list-style-type: none"> flow rate output current main totalizer daily totalizer with reset function 	<ul style="list-style-type: none"> language engineering units K-factor/Teach-In function measuring range 4...20 mA pulse output relay (option) filter reset main totalizer 	<ul style="list-style-type: none"> alteration of basic adjustment (offset, span) frequency test of sensor flow simulation

Description of the navigation keys

Large digital display with 8 characters (4 digital characters and 4 alphanumeric characters)

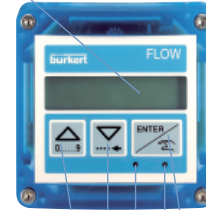

- Scrolling up the parameters within a level or a menu
- increase the figure selected
- Scrolling down the parameters within a level or a menu
- Selecting the figure on the left

- Selecting the displayed parameters
- Validating the settings

LED indicating relay 2 status

LED indicating relay 1 status

Dimensions [mm]

Panel-mounted version

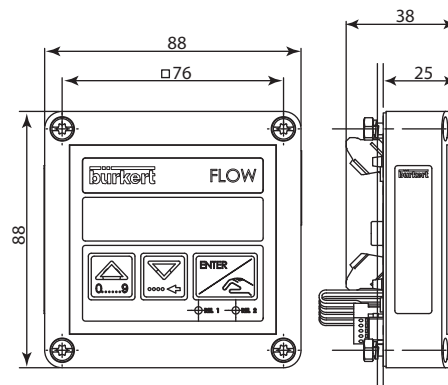

Wall-mounted version

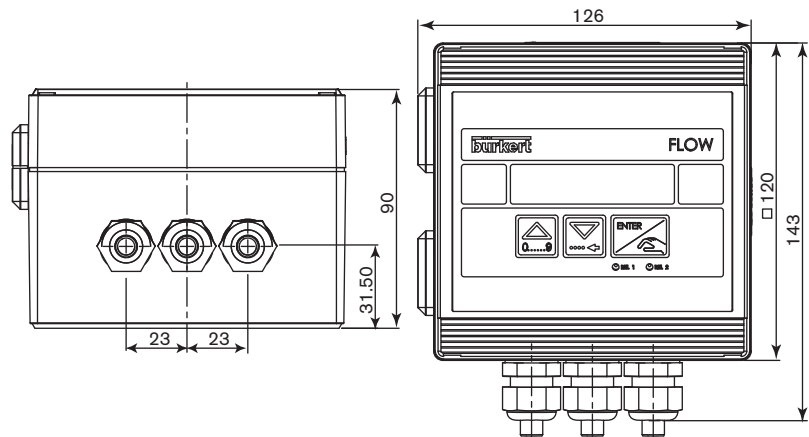

Ordering chart for remote transmitter Type 8025

Remote 8025 transmitter (panel- or wall-mounted) for connection to Bürkert “Low Power” flowmeter only.

A complete remote flow transmitter Type 8025 consists of:

- a remote transmitter Type 8025 (wall-mounted or panel-mounted)
- an INSERTION flowmeter Type 8020 or INLINE flow electronic SE30, (pulse “Low Power” version) (Refer to corresponding data sheet - has to be ordered separately)
- an INSERTION fitting S020 (DN20 - DN400), INLINE sensor fitting S030 (DN06 - DN65) or INLINE sensor fitting S070 (DN15 - DN100) (Refer to corresponding data sheet - has to be ordered separately)

Specifications	Voltage supply	Output	Relays	Sensor version	Electrical connection	Item no.
Transmitter, panel mounted, 2 totalizers	12...36 V DC	4...20 mA (2 wires) + pulse	None	8020/8030 ¹⁾ /8070 ²⁾	Terminal strip	418 992
		4...20 mA (3 wires) + pulse	2	8020/8030 ¹⁾ /8070 ²⁾	Terminal strip	418 994
Transmitter, panel mounted, 2 totalizers UL-Recognized for US and Canada 	12...36 V DC	4...20 mA (2 wires) + pulse	None	8020/8030 ¹⁾ /8070 ²⁾	Terminal strip	552 725
		4...20 mA (3 wires) + pulse	2	8020/8030 ¹⁾ /8070 ²⁾	Terminal strip	552 726
Transmitter, wall-mounted, 2 totalizers	12...36 V DC	4...20 mA (2 wires) + pulse	None	8020/8030 ¹⁾ /8070 ²⁾	3 cable glands	418 397
		4...20 mA (3 wires) + pulse	2	8020/8030 ¹⁾ /8070 ²⁾	3 cable glands	418 396
	115/230 V AC	4...20 mA (2 wires) + pulse	None	8020/8030 ¹⁾ /8070 ²⁾	3 cable glands	418 400
		4...20 mA (3 wires) + pulse	2	8020/8030 ¹⁾ /8070 ²⁾	3 cable glands	418 399

¹⁾ 8030 = SE30 + S030

²⁾ 8070 = SE30 + S070

NOTE: See the chart about compatible and recommended interconnection possibilities with Bürkert flowmeters on page 15 [go to page](#) .

Ordering chart - accessories for remote transmitter Type 8025 (has to be ordered separately)

Specifications	Item no.
Spare part, panel version	
Mounting set (screws, washer, nuts, cable clips)	554 807
Seal	419 350
Set with 8 FLOW foils	553 191
Spare part, wall version	
Power supply board 115/230 V AC + mounting instruction sheet	555 722

Interconnection possibilities with other Bürkert flowmeters

Flowmeter Type	Remote 8025 version			
	Universal transmitter		Transmitter	
	Panel	Wall	Panel	Wall
8020 Hall version (short or long) - Frequency output with pulse signal (NPN, PNP, Open Collector)	X	X	-	-
8020 Hall "Low Power" version (short or long) - Frequency output with pulse signal (NPN, Open Collector)	X	X	X	X
8030/8070 Hall version - Frequency output with pulse signal (NPN, PNP, Open Collector)	X	X	-	-
8030/8070 Hall "Low Power" version - Frequency output with pulse signal (NPN, Open Collector)	X	X	X	X
8030 High temperature - Frequency output with pulse signal (NPN, PNP, Open Collector)	X	X	-	-
SE30 Ex	X	X	-	-
8031 - Frequency output with pulse signal (NPN)	X	X	-	-
8041 - Frequency output with pulse signal (NPN)	X	X ¹⁾	-	-
8071 - Frequency output with pulse signal (NPN)	X	X	-	-

X = Compatible or recommended interconnection possibilities

¹⁾ except device with Item no. 419543

