



## ABB high dynamic servo drive packages MicroFlex and BSM R series

# ABB high dynamic servo drive packages

## MicroFlex and BSM-R series

ABB high dynamic servo packages bring together ABB's BSM R series brushless servo motors and MicroFlex series servo drives to create cost and performance optimized packages. These provide a flexible choice of input control and feedback options, offering scalable solutions for motion and position synchronization as well as torque and speed control.

The advanced yet simple to use MicroFlex servo drive family is available in three versions with graded functionality and straightforward configuration using a single intuitive software tool. When combined with the compact and durable BSM R series brushless servo motors, peak torques range from 0.95 N·m to over 7 N·m (8.41 to 73 lb-in). Applications can use single-axis step and direction control, +/- 10 V dc control, standalone MINT programmable motion, or real-time multi-axis Ethernet networked positioning.



## Contents

2 - 5	ABB high dynamic servo drive packages
6 - 7	Applications & Industries
8 - 9	BSM R series motors - Technology highlights
10 - 11	MicroFlex family servo drives - Technology highlights
12	Intuitive drive commissioning tools
13	Motion programming
14	Selecting BSM R and MicroFlex combinations
15	BSM R combinations with MicroFlex servo drives
16 - 19	BSM R technical and ordering details
20 - 23	MicroFlex technical and ordering details
24 - 25	Accessories
26 - 27	Related ABB products

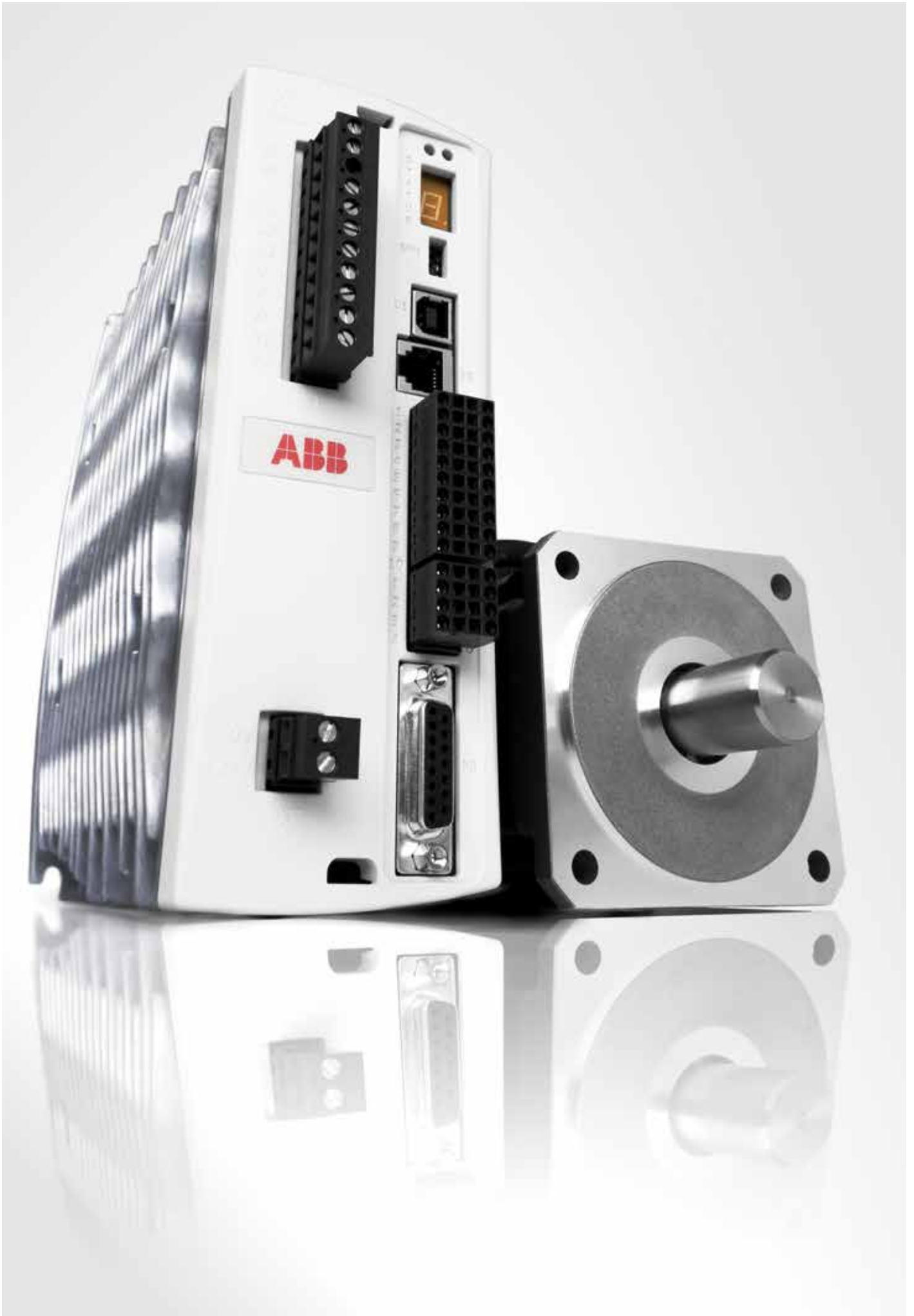

# Applications and industries

High throughput with smooth speed and fast settling times are important machine design requirements. ABB high dynamic servo packages with advanced motor controls are ideal for these applications, providing dynamic acceleration and high torque density. A choice of incremental encoder or high resolution absolute feedback suits precision tasks, whilst resolver feedback offers improved durability.

Choose between simple analog or digital input control through to intelligent drives that can fulfill single-axis standalone motion control or tightly synchronized multi-axis motion in combination with ABB's motion or PLC controls.

This flexible and adaptable range offers solutions for:

- Cut-to-length
- Infeed control
- Flying shear
- Electronic gearbox
- High speed registration
- Point-to-point positioning
- Synchronized multi-axis motion

Applications include:

- Robotics/Pick and place
- Material handling
- Labeling machines
- Packaging machines
- Winding machines
- Printing machines
- Dispensing machines

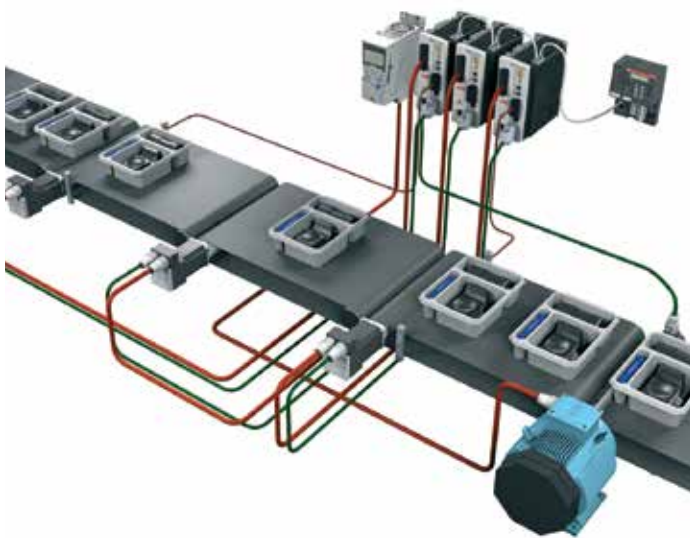





# BSM R series motors - Technology highlights

## BSM R servomotors for dynamic precision motion

Thanks to its high torque density and low rotor inertia, the BSM R series servomotor is perfect for highly dynamic, precision motion. A choice of resolver, 2000 line encoder or single- and multi-turn high resolution absolute encoder feedback options are available to match application requirements; resolver for rugged environments and absolute high resolution encoders for greater performance.

BSM R-Series motor housings are IP65 rated and an optional oil shaft seal may be added to increase protection of the motor face to IP65. With power ratings from 100 to 750 watts, in two nominal square frame sizes of 60 and 80 mm, the range is available with an optional brake. Flying leads provide easy connection of both motor power and feedback.

## Compact and rugged brushless motors

Available in two square frame sizes, 60 and 80 mm, with high torque to inertia ratio and rapid acceleration capability.

## Practical installation options

A choice of free cables or bales with connector interfacing provides flexible choice of drive interfacing.

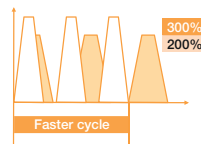

## Practical options for high dynamic applications

A 24 V DC brake is available and an optional oil seal provides front face IP65 rating.



### Flexible feedback options

Choose from resolver, 2000 line encoder or high resolution single- and multi-turn SmartAbs absolute encoder.



	Resolver	2000 line incremental	SmartAbs Singleturn & Multiturn
	<ul style="list-style-type: none"> <li>• High shock and vibration</li> <li>• Durability for extreme environments</li> </ul>	<ul style="list-style-type: none"> <li>• Excellent cost &amp; performance balance for many applications</li> </ul>	<ul style="list-style-type: none"> <li>• Higher resolution</li> <li>• Tighter control</li> <li>• Faster settling time</li> <li>• Absolute position - no datum routine</li> </ul>
Durability	■ ■ ■ ■ ■	■ ■ ■ ■ ■	■ ■ ■ ■ ■
Temperature range	■ ■ ■ ■ ■	■ ■ ■ ■ ■	■ ■ ■ ■ ■
Vibration	■ ■ ■ ■ ■	■ ■ ■ ■	■ ■ ■ ■ ■
Precision	■ ■ ■ ■ ■	■ ■ ■ ■ ■	■ ■ ■ ■ ■ ■ ■ ■
Resolution	■ ■ ■ ■	■ ■ ■ ■ ■	■ ■ ■ ■ ■ ■ ■ ■
High dynamics (faster settling etc.)	■ ■ ■ ■ ■	■ ■ ■ ■ ■	■ ■ ■ ■ ■ ■ ■ ■
Low cost	■ ■ ■ ■ ■	■ ■ ■ ■ ■	■ ■ ■ ■ ■

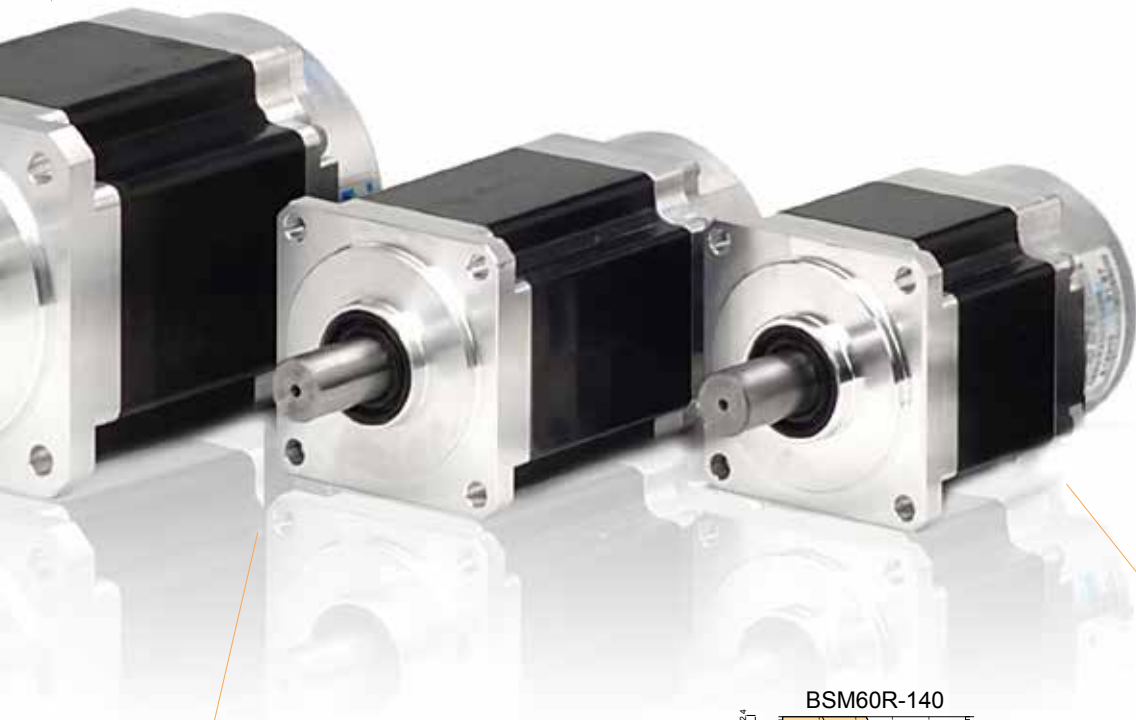

### Approvals and protection

BSM R series motors have UL, cUL, CE approval and IP66 protection option

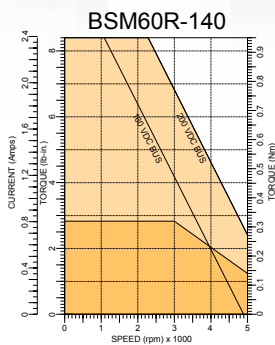

### Dynamic performance

With a choice of 100, 200, 400, 750 watt output and continuous torque from 0.318 to 2.39 N·m (2.81 - 21.12 lb-in).

# MicroFlex family servo drives - Technology highlights

## Perfectly matched for BSM R series motors

ABB's MicroFlex family offers a choice of 3, 6 and 9 A rms current ratings from a direct-on-line 105 to 250 V AC supply to suit the BSM R power ratings from 100 to 750 W.

**MicroFlex Analog** servo drives are available for +/- 10 V and step and direction control. The **MicroFlex e150** intelligent drive provides MINT programmable single-axis solutions, can be used in multi-axis EtherCAT networks for advanced motion and machine control, and also features Modbus TCP and Ethernet/IP.

## Common drive features

- Direct online single-phase 105-250 VAC or 3 phase 230VAC
- 3, 6 or 9 Amp continuous with 200% overload for 3 seconds
- Control of both rotary and linear servo motors
- 300% overload mode also available with reduced rms ratings

## HMI via Modbus

2- or 4- wire RS485 port with switch selectable termination and featuring Modbus RTU and custom ASCII protocols using MINT for PLC, HMI or other device communications.



## Two high speed registration inputs

Precise registration of print marks or product position achieved with 2 x 24V fast isolated inputs that can be used to latch feedback device position in hardware and trigger software events locally in MINT.

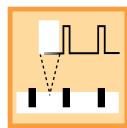

## I/O – digital and analog

I/O used for configurable drive functions, such as end limits or home sensor or within MINT programming for typical machine functions such as push buttons.



## Dual encoder

Dual encoder input for position and commutation. Provides line shaft following or dual loop control to eliminate mechanical errors. Supports one incremental (no Halls) and one serial encoder or resolver.

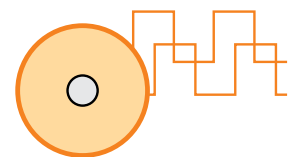



## EtherCAT



### AC500 PLC EtherCAT solutions

Integrated Ethernet interface offers EtherCAT® for real-time control of multi-axis systems. Ethernet/IP™, Modbus TCP and RAW Ethernet are supported on the generic Ethernet port to operate with controllers such as PLC and industrial PCs.



### Safety

Safe torque-off (STO) SIL3 PLe is a standard feature. STO prevents rotation for machine safety applications, eliminating the need to remove AC power in most applications, minimizing downtime and maximizing machine utilisation.

### Advanced motion programming

Intelligent drive, offering MINT programming - a high level multitasking language - tailored for motion applications. This powerful but simple programming language, within MINT WorkBench, provides control of communications, logic, motion and HMI interactions.

### Compact and rugged brushless motors

Available in two square frame sizes, 60 and 80 mm, with high torque to inertia ratio and rapid acceleration capability.



### 25% more torque

#### Dynamic overload

A peak overload of 300 percent of rms current maximizes available torque for dynamic acceleration. 300 percent peak torque delivers faster cycle times and increased productivity.

### Universal digital feedback

Ethernet and motor encoder feedback interfaces are highly integrated and optimized for demanding motion applications.





# Selecting BSM R and MicroFlex combinations

- 1 – Having calculated your application torque and speed requirements, use the speed/torque table and graphs on pages 12 & 13 to select the most suitable BSM R motor and note its power rating in watts.



- 2 – Using the table opposite, select the control function you need. The table guides you to a choice of MicroFlex Analog (for +/- 10 V servo control or a step and direction) or MicroFlex e150 (for MINT programmable or Ethernet).
- 3 – Choose the motor feedback you prefer in combination with the power rating of the motor you selected in step 1 - this will guide you to motor and drive part numbers for ordering.
- 4 – You also need to determine if a brake or shaft oil seal is required for the motor to complete its part number.
- 5 – Finally, if you have chosen the MicroFlex e150 drive, you need to complete its part number depending upon Ethernet connectivity or MINT programming.

# BSM R combinations with MicroFlex servo drives

Control selection <b>2</b>		Analog +/- 10 V OR Pulse Train Input		Ethernet OR MINT programmable <b>5</b>			
Drive type and features	MicroFlex Analog			MicroFlex e150			
		 <p>Analog +/- 10 V</p> <p>±10V Analog demand 5V step and direction</p>			 <p>Ethernet/IP and Modbus TCP EtherCAT for real time control Safe torque-off (STO) to SIL3 PLe Advanced MINT programming (option)* Resolver adapter</p>		
Motor selection	Feedback <b>3</b>	Motor Part Number*	Drive Part Number*	Feedback <b>3</b>	Motor Part Number*	Drive Part Number **	
Motor Power	100W	Resolver	BSM60R-140xA	FMH2A03TR-RN23W	Resolver	BSM60R-140xA	E152A03EIxA + OPT-MF-201
		Encoder	BSM60R-140xG	FMH2A03TR-EN23W	Encoder	BSM60R-140xG	E152A03EIxA
					Absolute single turn	BSM60R-140xT	
	200W	Resolver	BSM60R-240xA	FMH2A06TR-RN23W	Resolver	BSM60R-240xA	E152A03EIxA + OPT-MF-201
					Encoder	BSM60R-240xG	E152A03EIxA
		Encoder	BSM60R-240xG	FMH2A03TR-EN23W	Absolute single turn	BSM60R-240xT	
	Absolute Multi turn				BSM60R-240xT2		
	400W	Resolver	BSM60R-340xA	FMH2A03TR-RN23W	Resolver	BSM60R-340xA	E152A06EIxA + OPT-MF-201
					Encoder	BSM60R-340xG	E152A06EIxA
		Encoder	BSM60R-340xG	FMH2A03TR-EN23W	Absolute single turn	BSM60R-340xT	
	Absolute Multi turn				BSM60R-340xT2		
	750W	Resolver	BSM80R-340xA	FMH2A06TR-RN23W	Resolver	BSM80R-340xA	E152A06EIxA + OPT-MF-201
Encoder					BSM80R-340xG	E152A06EIxA	
Encoder		BSM80R-340xG	FMH2A03TR-EN23W	Absolute single turn	BSM80R-340xT		
	Absolute Multi turn			BSM80R-340xT2			

Note: \* Motor selection option x = brake and/or shaft seal, or no options (see page 19)

\*\* MicroFlex drive build option 'x', N = EtherCAT servo drive, O = MINT programming option (see page 23)

# BSM R performance and specification

Catalog Number		BSM60R-140XX	BSM60R-240XX	BSM60R-340XX	BSM80R-340XX
Output power <b>1</b>	Watts	100	200	400	750
<b>General</b>					
Rated torque	Nm	0.32	0.64	1.27	2.39
Rated current	Arms	0.9	1.7	3.3	5.0
Peak torque	Nm	0.95	1.91	3.82	7.16
Peak current	Arms	2.6	5.0	9.7	14.5
Continuous stall torque	N·m	0.32	0.64	1.27	2.39
Continuous current	Arms	0.8	1.6	3.2	4.8
Rated speed	rpm	3000	3000	3000	3000
<b>Electrical</b>					
Torque constant	N·m/amp	0.38	0.39	0.40	0.50
Voltage constant	Vrms/krpm	23.0	23.7	24.0	30.1
Resistance	Ohms	13.47	5.00	1.93	0.87
Inductance	mH	33.33	16.00	7.33	5.20
Electrical time constant	ms	2.5	3.2	3.8	6.0
<b>Mechanical</b>					
Inertia [with brake]	kg·cm <sup>2</sup>	0.18	0.27	0.43	1.30
[without brake]		0.086	0.18	0.34	1.06
Maximum speed	rpm	5000	5000	5000	5000
Mechanical time constant [with brake]	ms	2.5	1.3	0.8	0.7
[without brake]		1.2	0.9	0.6	0.6
Number of motor poles		8	8	8	8
Max radial load	N (at 20mm)	78.4	196.0	196.0	343.0
Max thrust load	N	39.2	68.6	68.6	98
Weight [with brake]	kg	0.9	1.4	1.8	3.4
[without brake]		0.6	0.9	1.3	2.5
<b>Brake data</b>					
Rated voltage	VDC ±10%	24	24	24	24
Rated torque (min)	Nm	1.27	1.27	1.27	2.39
Rated current	Arms	0.33	0.33	0.33	0.33
Rated input power	W	8	8	8	8
Armature release time (max)	ms	20	20	20	30
Armature pull-in time (max)	ms	50	50	50	60



# BSM R performance and specification

**BSM60R-140**  
**100W**

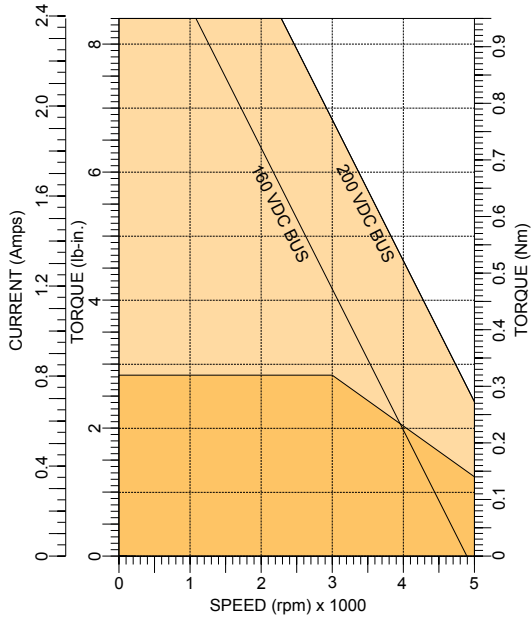

**BSM60R-240**  
**200W**

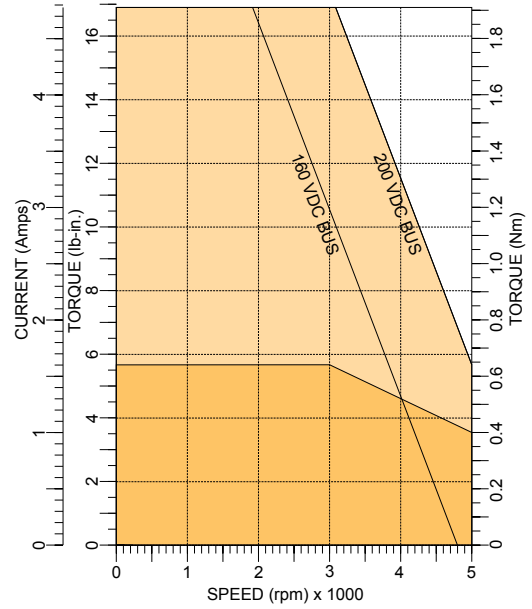

**BSM60R-340**  
**400W**

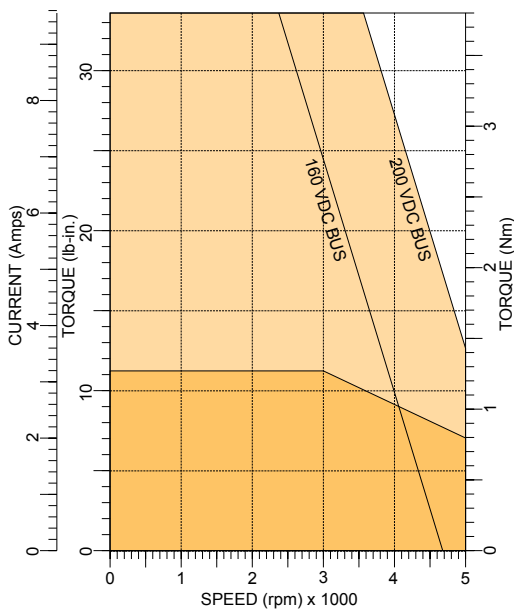

**BSM80R-340**  
**750W**

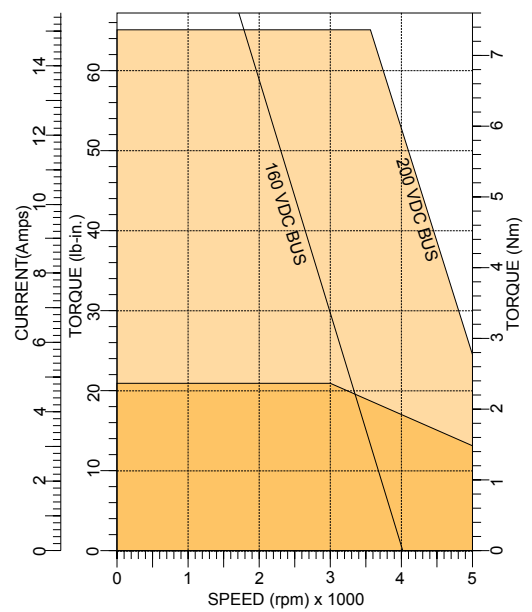

# BSM R dimensions

## BSM60R-140

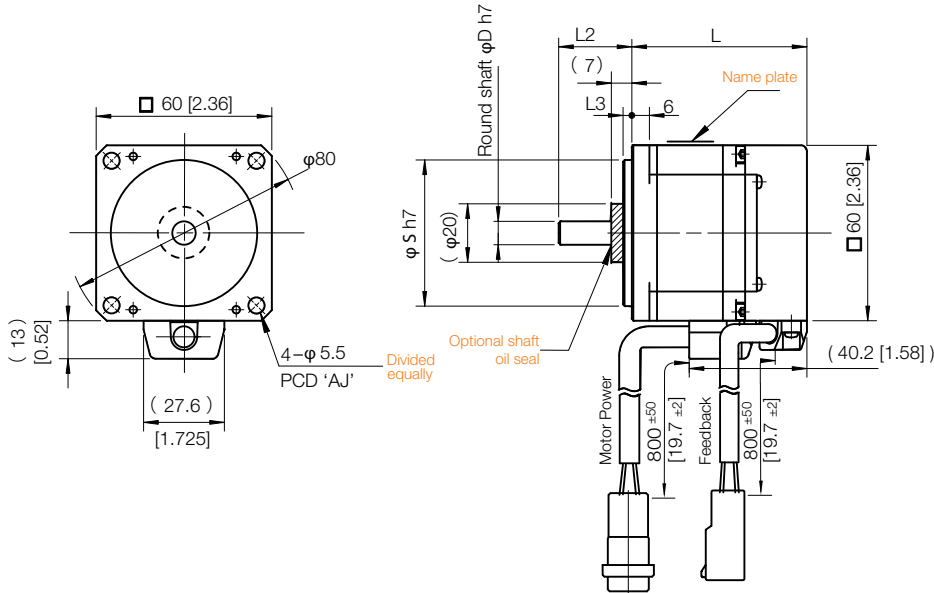

## BSM60R-240 / 340

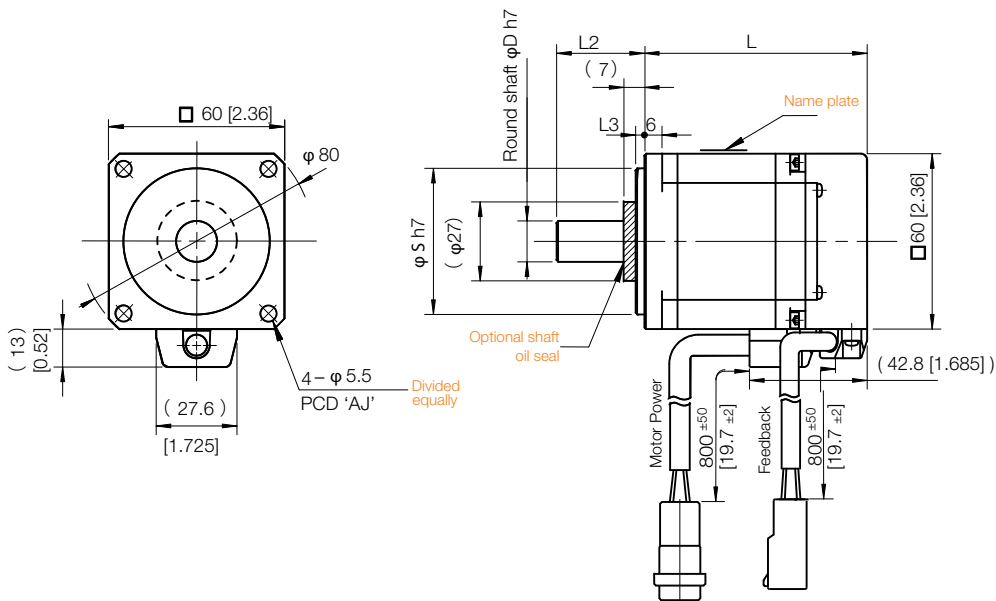

## BSM80R-340

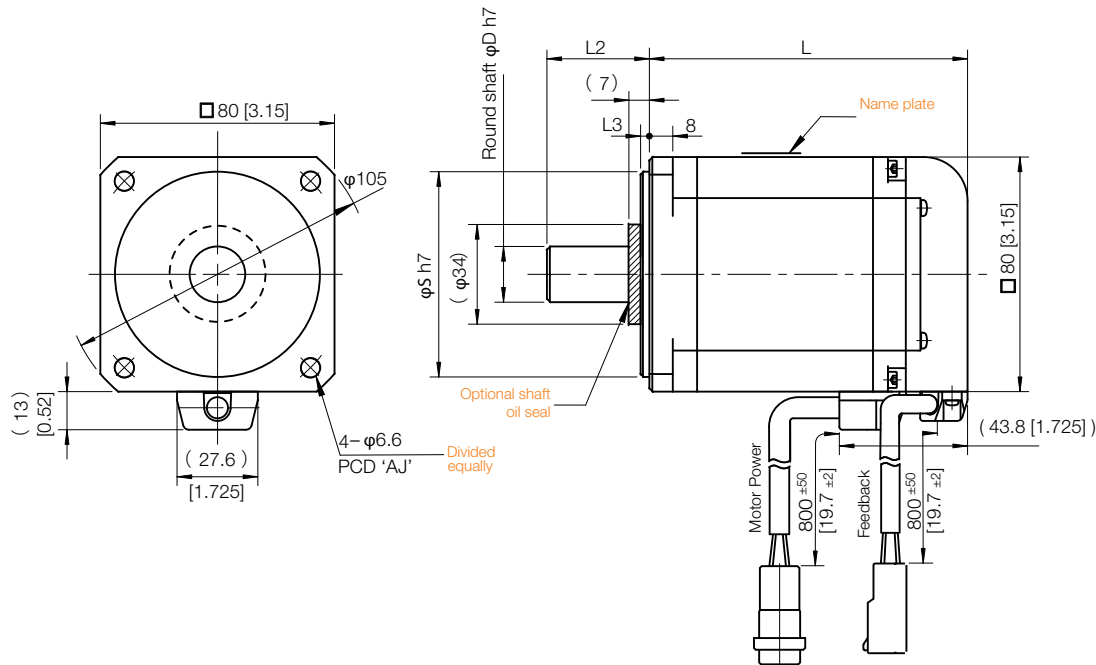

Catalog Number	Length (L) mm [in]		L2 mm [in]	D mm [in]	L3 mm [in]	S mm [in]	AJ mm [in]
	W/O brake	W/brake					
BSM60R-140xx	59 [2.35]	83 [3.3]	30 [1.181]	8.0 [0.315]	3.0 [0.118]	50 [1.968]	70 (2.76)
BSM60R-240xx	76 [3.0]	111 [4.36]	30 [1.181]	14.0 [0.551]	3.0 [0.118]	50 [1.968]	70 (2.76)
BSM60R-340xx	98 [3.86]	132 [5.20]	30 [1.181]	14.0 [0.551]	3.0 [0.118]	50 [1.968]	70 (2.76)
BSM80R-340xx	108 [4.25]	145 [5.7]	35 [1.381]	19.0 [0.748]	3.0 [0.118]	70 [2.755]	90 (3.54)

## BSM R ordering information

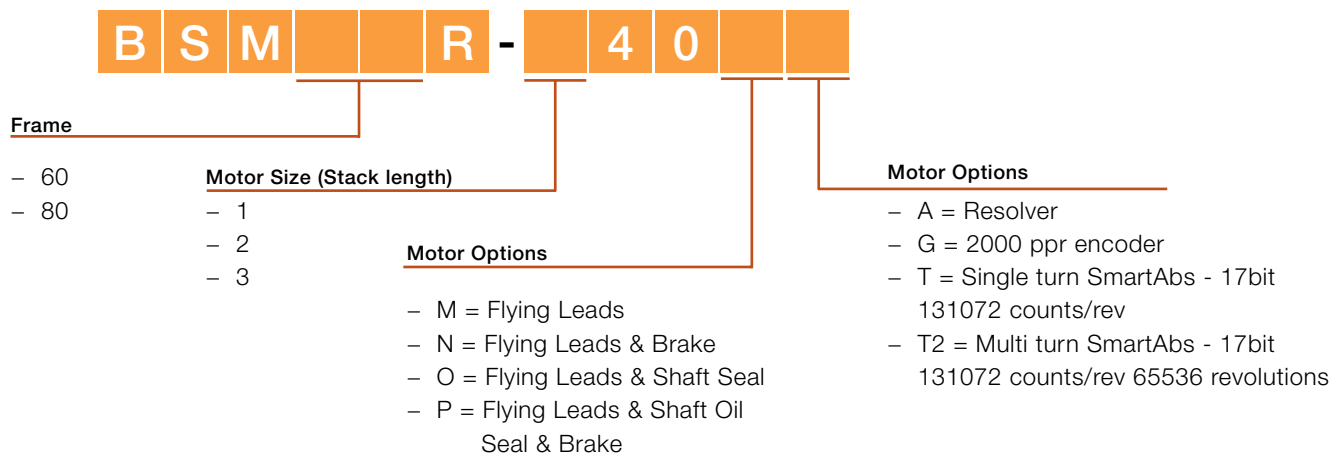

## MicroFlex series drives for flexible motion control

ABB's MicroFlex series drives share a common drive stage with up to 9 A continuous current rating and operation with single and three-phase supplies to suit global markets. A flexible choice of control and communication options allow the range to be used across a wide variety of applications from simple analog and step/direction or EtherCAT®

MicroFlex motion drives include common intuitive set-up and programming options for single and multi-axis tasks. They may also be combined with our multi-axis motion controllers and PLC products for system solutions.

### MicroFlex series common features

- 1 or 3-phase operation from 105 to 250 V AC
- 3, 6 and 9 A rms
- 200% overload standard (300% on MicroFlex e150)
- IP20 enclosure for cabinet installation (UL open)
- Auto-tuning and anti-resonance digital filters
- Suitable for single drive and multi-axis systems
- Controls rotary and linear AC servo motors
- Options
  - Space saving footprint EMC filter
  - Brake unit
  - Regen resistors

For further information, see flyer "ABB motion control drives, MicroFlex brushless AC servo drives", code: 3AUA0000123110 EN.





# MicroFlex Analog

## MicroFlex Analog servo drive

The ABB MicroFlex Analog is a compact brushless servo drive, suitable for single or three-phase 105 to 250 V AC operation, with current ratings of 3, 6 and 9 A.

The motor feedback is software programmable, accepting encoder with halls or halls only. Resolver feedback is available as a factory fit option.

MINT WorkBench provides full auto-tuning capabilities and wizard based configuration. Extended capabilities include programmable notch and low pass filters to reduce or remove resonance in a machine.

The ABB MicroFlex Analog provides high performance servo control for both rotary and linear brushless motors with its powerful DSP (digital signal processor) core.

For multi-axis systems, MicroFlex Analog can be used with the compact panel mount motion controller NextMove ESB-2 for control of up to 8 axes: 4 servo, 4 open loop step and direction (stepper).



### MicroFlex Analog

- $\pm 10$  V analog demand
- 5 V step and direction
- Simulated encoder output
- Serial port for drive configuration (RS232 or RS422)

For further information, see flyer "ABB motion control drives, MicroFlex brushless AC servo drives", code: 3AUA0000123110 EN.

Feature	Advantage	Benefit
External 24V logic supply	Supports control electronics even when the main power is off	Maintains drive status and simulated encoder output to an external controller to reduce the need to re-datum after main AC power is removed
Built-in brake chopper	On-board braking capability	More dynamic movements possible
Resolver or encoder options	Ability to interface with industry standard feedback devices	Select feedback device of choice to match application demands of precision or higher mechanical resilience
RS232 and serial communications	serial port is RS232 or RS422 (depending on drive variant)	Improved application interfaces (supported by free ActiveX components)

# MicroFlex e150

## MicroFlex e150 servo drive

The ABB MicroFlex e150 servo drive combines Ethernet technology, advanced multi-tasking programming and single-phase operation in a compact package. Ethernet and motor encoder feedback interfaces are fully integrated and optimized for demanding motion applications, while Safe Torque Off is a standard feature which can help manufacturers meet European machinery directives easily.

ABB MicroFlex e150 is ideally suited to integration with the AC500 PLC range with EtherCAT or Modbus TCP control. The integrated Ethernet interface offers EtherCAT for real-time control of multi-axis systems. In addition, EtherNet/IP™, Modbus TCP and RAW Ethernet are supported to enable control possibilities with other controllers such as PLC and industrial PCs.

The MicroFlex e150 intelligent drive is available in a choice of MINT programming or EtherCAT only versions for even more flexibility.



### MicroFlex e150

- Ethernet/IP and Modbus TCP
- EtherCAT for real time control
- Safe Torque Off (STO) to SIL3 PL e as standard
- 300% overload capability
- I/O compliment: 10 x DI, 7 x DO, 2 x AI and 1 x AO
- Advanced MINT programming (option)
- Resolver adapter
- Encoder splitter for dual encoder or simplified linear motor connection

For further information, see flyer "ABB motion control products, MicroFlex e150 servo drives", code: 3AUA0000097609 EN.

Feature	Advantage	Benefit
Safe Torque Off (STO)	Built in machine safety features to SIL3 PL e.	Able to integrate into safety systems without extra equipment
EtherCAT	Real-time control single Ethernet cable – no need for additional Fieldbus. High-speed real-time communications	Reduced hardware requirements, less cabling, reduced system design requirements and cheaper cabling solutions
MINT motion control	Advanced motion programming	Powerful MINT multi-tasking software. Motion capability including linear motion, indexing, tuning, registration and more
External 24 V logic supply	Support control electronics even when mains power is off	Maintain present positional information in a power outage. Allows immediate restart without the need to datum
Motor feedback - universal encoder	Ability to interface with industry standard feedback devices	Select feedback device of choice to match application demands of precision or higher mechanical resilience
USB and serial communications	USB for configuration and customer PC	Improved application interfaces (supported by free ActiveX components). RS485 serial comms for PLC, HMI or other device communications

## Ordering information: MicroFlex series

MicroFlex Analog			
Input voltage		1/3 phase 105-250 V AC	
Bus voltage		160-320 V dc	
Output current amps (rms)		Catalog number RS232 * **	Catalog number RS422 * **
Continuous	Peak	Encoder feedback	
3	6	FMH2A03TR-EN23W	FMH2A03TR-EN43W
6	12	FMH2A06TR-EN23W ***	FMH2A06TR-EN43W ***
9	18	FMH2A09TR-EN23W ***	FMH2A09TR-EN43W ***
		Resolver feedback	
3	6	FMH2A03TR-RN23W	FMH2A03TR-RN43W
6	12	FMH2A06TR-RN23W ***	FMH2A06TR-RN43W ***
9	18	FMH2A09TR-RN23W ***	FMH2A09TR-RN43W ***

NOTE: See ABB power supplies, 1SVR4270#, CP-E/C

\* Order regen resistor separately. \*\* Customer must supply +24 V DC for I/O operation. \*\*\* Requires external ventilation. See fan kits

MicroFlex e150 (EtherCAT, Ethernet/IP, Modbus TCP/IP, MINT programming)		
Input voltage		1/3 phase 105-250 V AC
Bus voltage		160-320 V
Output current amps (rms)		Catalog number * **
Continuous	Peak	
3	6	E152A03EIOA
6	12	E152A06EIOA ***

NOTE: Will accept either incremental or absolute encoder feedback (BiSS, EnDat, SSI, SmartAbs®).

See ABB power supplies, 1SVR4270#, CP-E/C. For slave device functions, see the MicroFlex e150 “Option Type” chart in the Automation Solutions section: ABB EtherCAT multi-axis with AC500 PLC

\* Order regen resistor separately (see Accessories). \*\* Customer must supply +24 V DC for I/O operation.

\*\*\* Requires external ventilation. See fan kits.

# Easy PC tool for configuration and machine tuning

MINT WorkBench is a Windows tool for ABB's range of motion controllers and servo drives providing simple drive set-up, motion programming of intelligent drives and multi-axis motion controllers.

## Drive commissioning made easy

Drive commissioning is simplified by a step by step wizard that guides the user through motor selection and application choices and finally an autotuning system that makes light work of system tuning.

## Features include:

- Wizards to simplify 'expert' tasks such as configuration of drives and networks
- Full screen editor with color syntax highlighting and debugging capabilities
- Command line interface to interrogate the controller even when the program is running
- Spy window to monitor common motion variables, I/O, communications and more
- 6 channel software oscilloscope
- Watch window for monitoring variables and tasks
- SupportMe function with automatic email generation for rapid technical support
- Web updates of firmware within the MINT WorkBench
- Easy management of firmware files and updates

## Intelligent support with one click

If you are using one of our electronic products that requires the use of MINT WorkBench, the SupportMe function will gather important information about your device configuration and environment. This information helps our engineers in assisting you with your enquiry and going straight to the point.

## Motion programming made easy

MINT WorkBench offers an easy to use development platform for MINT programming with its color syntax highlighting of keywords. The context sensitive help provides you clear instructions of each command word and gives you tips for using it without the need for a user manual. The Program Navigator makes it a breeze to navigate the source code, no matter how complicated.

## MINT motion programming

MINT is the programming language for our range of motion controllers and programmable drives. Designed around Basic, MINT will be familiar to many with its English like keywords and high level functionality.

## MINT offers:

- Motion, machine logic, communications and HMI
- Multitasking for streamlined performance
- Functions, procedures, events
- Modular coding approach
- Modern development and debugging environment
- ActiveX support





# Feature-rich, intelligent drive solutions

## MicroFlex e150 MINT - supported motion features



### Homing (Referencing / Daturing)

Homing provides a configurable approach to finding a start or reference position for an axis. This can also be avoided altogether on MicroFlex e150 products using absolute encoders.



### Jerk control (S ramp)

Jerk limitation controls the rate of change of acceleration during motion, to provide a smooth control reducing shock and vibration on the load. This results in 'softer' motion and improves mechanical life of the system.



### Registration control / EVENT Handling

Fast inputs provide position LATCH functionality that can automatically trigger software EVENTS to perform calculations, logic checks and even positional corrections at high speed. Useful for registration functions.



### Electronic gearing with simulated clutch and registration features

Replace mechanical linkages with software gearing that can be dynamically controlled at the touch of a button. Change ratio, advance or retard an axis, simulate mechanical clutch engage / disengage



### JOG (in position or velocity control)

Jogging of an axis while maintaining position control. Combined with JERK control provides a smooth method to adjust an axis or run a conveyor for example.



### FLY - Flying shear segments

FLY segments provide a means to create simple or complex motion which is 'geared' to a second axis (master encoder) position. Effectively time is replaced by position of the master axis.



### INCR/A target change on the fly

Final position of an axis can be adjusted 'on the fly' to compensate for some measurement or trigger, for example, cut to length of printed material, accurate product positioning, press feeder applications, etc.



### Electronic CAMs

Software CAMs eliminate mechanical wear or 'bounce' issues associated with mechanical systems. CAM data can be changed for different 'recipes' or dynamically varied during operation.



### Splines and PVT profiles

Spline and PVT (Position Velocity Time) motion use a series of data points and interpolation to provide smooth path control. Useful for 'record and replay' functions for example (single axis only).



### Incremental / Absolute Moves

Simple point to point motion.

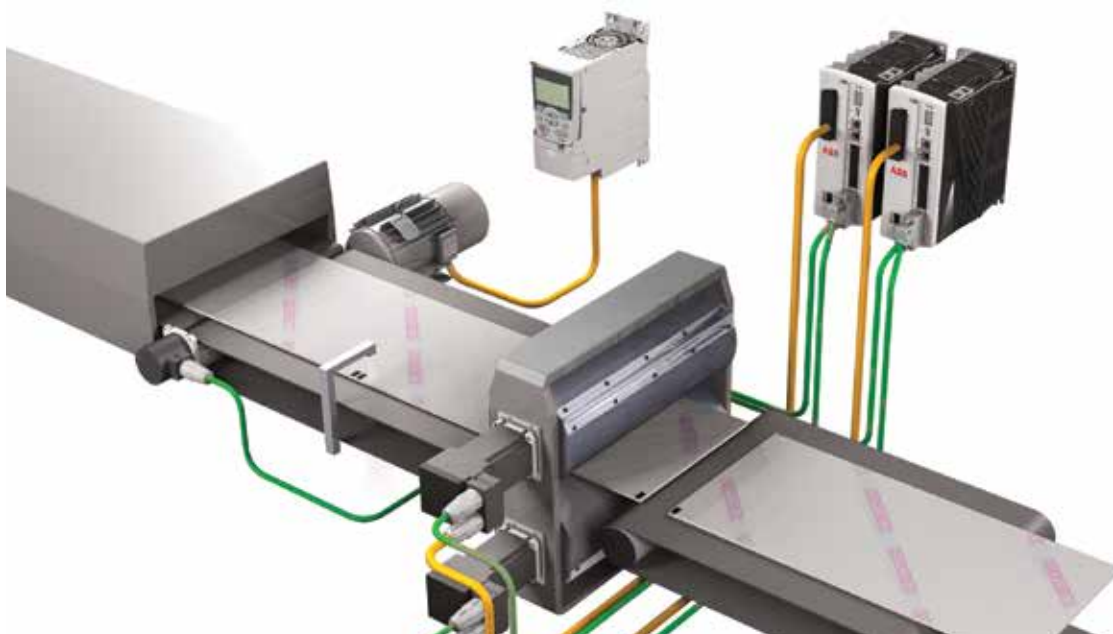

## Accessories: MicroFlex series

Accessories (MicroFlex Analog)	
Description	Catalog number
Fan kit, 24 V DC	FAN001-024
MicroFlex resolver connector kit	OPT-ACC001-509
MicroFlex encoder connector kit	OPT-ACC001-507
RS232 serial cable	CBL001-501
USB signal isolator	OPT-CNV-003
Accessories (MicroFlex e150)	
Description	Catalog number
Resolver adapter	OPT-MF-201
Encoder splitter	OPT-MF-200
Fan kit, 24 V DC	FAN001-024
Mint WorkBench-Programming and Commissioning	See website
USB cable 1m/3.3ft	CBL010CM-USB
USB cable 2m/6.6ft	CBL020CM-USB
USB cable 3m/9.8ft	CBL030CM-USB
USB isolator	OPT-CNV-003
MicroFlex e150 connector set	OPT-MF-CN-A
MicroFlex e150 encoder breakout*	OPT-MF-200

NOTE: \* The breakout splits the necessary encoder signals to provide easy connection of an incremental ABZ encoder and a serial based encoder at the same time. The purpose is to allow dual encoder support for either dual feedback or master follower. Encoder breakout also provides for convenient connection of encoder and Hall feedback cables from linear motors.

Cables-e150 to e150 Ethernet - communication cables	
Description	Catalog number
Ethernet cable: shielded cat5e RJ45 0.2 m/0.7 ft.	CBL002CM-EXS
Ethernet cable: shielded cat5e RJ45 0.5 m/1.6 ft.	CBL005CM-EXS
Ethernet cable: shielded cat5e RJ45 1.0 m/3.2 ft.	CBL010CM-EXS
Ethernet cable: shielded cat5e RJ45 2.0 m/6.5 ft.	CBL020CM-EXS
Ethernet cable: shielded cat5e RJ45 5.0 m/16.3 ft.	CBL050CM-EXS
Ethernet cable: shielded cat5e RJ45 10.0 m/32.6 ft.	CBL100CM-EXS

A large selection of resolver and encoder motor feedback cables is also available - please see website <http://www.abbmotion.com/products/accessories/cables>

Regen resistors	
Description	Catalog number
100W regen resistor 39 Ohms	RGJ139
100W regen resistor 60 Ohms	RGJ160
200W regen resistor 60 Ohms	RGJ260
300W regen resistor 60 Ohms	RGJ360

EMC Filters for CE	
Description	Catalog number
Foot-mount filter, suitable for all ratings.	F10029A00
Filter for 3A single phase input	F10015A00
Filter for 3A three phase input	F10018A00
Filter for 6A single phase input	F10015A02
Filter for 6A three phase input	F10018A00
Filter for 9A single phase input	F10029A00
Filter for 9A three phase input	F10018A03
Filter for 24V supply	F10014A00



# ABB automation products



## Motion controllers

ABB offers a wide range of motion control products to suit many different applications. Motion controllers are available in PCI format, as standalone units with USB, CANopen, serial and Ethernet interfaces and as intelligent programmable drives for use in single or multi-axis systems.



## Servo drives

ABB offers a range of servo drives to cover many different applications. Its drives range from simple analog, fieldbus controlled drives, indexing drives, fully programmable motion drives and real-time Ethernet solutions based on the open standard Ethernet POWERLINK and EtherCAT. ABB motion drives control rotary and linear AC servo motors, and are available from 1 A single phase through to 65 A three phase.



## Machinery drives

ABB offers machinery builders AC drives from component drives up to high performance machinery drives. Global support and service guarantees lifelong satisfaction. ABB machinery drives provide speed control of diverse applications from spa bath motors to treadmill motors, as well as high precision applications such as positioning and synchronization systems.



## Control panels

Our control panels offer a wide range of touchscreen graphical displays from 3.5" up to 15". They are provided with user-friendly configuration software that enables tailor made customized HMI solutions. Rich sets of graphical symbols and the relevant drivers for ABB automation products are provided. Control panels for visualization of AC500 web server applications are available.



## Servo motors

ABB's BSM series servo motors offer a wide choice of high or low inertia models with winding options, feedback devices and gearheads to match. All ABB servo motors are designed for durability and ability to handle harsh environments.



## AC motors

ABB's low voltage AC motors are designed to save energy, reduce operating costs and enable demanding motor applications to perform reliably and without unscheduled downtime. General performance motors combine convenience and easy handling seamlessly with ABB's engineering expertise. Process performance motors provide the most comprehensive, versatile set of motors for the process industries and heavy-duty applications.



## Jokab safety products

ABB Jokab Safety offers an extensive range of innovative products and solutions for machine safety systems. It is represented in standardization organisations for machine safety and works daily with the practical application of safety requirements in combination with production requirements. ABB Jokab Safety delivers everything from a single safety solution to complete safety systems for single machines or entire production lines.

# ABB automation products



## AC500

ABB's powerful flagship PLC offering a wide range of performance levels and scalability within a single simple concept where most competitors require multiple product ranges to deliver similar functionality. Web server integrated and IEC 60870-5-104 remote control protocol for all Ethernet versions.



## AC500-eCo

Meets the cost-effective demands of the small PLC market whilst offering total inter-operability with the core AC500 range. Web server, FTP server and Modbus-TCP for all Ethernet versions. A Pulse Train Output module is available for multi-axis positioning.



## AC500-S

A PLC based modular automation solution that makes it easier than before to mix and match standard and safety I/O modules to expertly meet your safety requirements in all functional safety applications. "Extreme conditions" version is also offered.



## AC500-XC

"Extreme conditions" modules with extended operating temperature, immunity to vibration and hazardous gases, for use at high altitudes, in humid conditions, etc. It replaces expensive cabinets with its built-in protection against dirt, water, gases and dust.



## Programming software

Automation Builder integrates the engineering and maintenance for PLC, drives, motion, HMI and robotics. It complies with the IEC 61131-3 standard offering all five IEC programming languages for PLC and drive configuration. In addition, it includes continuous function chart, C, extensive function block libraries and powerful embedded simulation/visualization features.

Automation Builder supports a number of languages (English, German, French, Chinese, Spanish) and comes with new libraries, FTP functions, SMTP, SNTP, smart diagnostics and debugging capabilities.



## Robotics

ABB's robotic automation offers cell automation by integrating AC500 PLCs in IRC5 robot controllers. More productivity with robots is achieved by wireless interfaces for sensors and actuators on robot tools. Wireless from ABB is an innovative, proven solution well-suited for robots, presses, rotary tables and gantries.



## I/O modules

Centralised I/O expansion of the AC500 line and decentralised modular I/O supporting CS31, CANopen, PROFIBUS® DP, PROFINET® and EtherCAT.







**Notes:**

We reserve the right to make technical changes or modify the contents of this document without prior notice. With regard to purchase orders, the agreed particulars shall prevail. ABB does not accept any responsibility whatsoever for potential errors or possible lack of information in this document.

We reserve all rights in this document and in the subject matter and illustrations contained therein. Any reproduction, disclosure to third parties or utilization of its contents – in whole or in parts – is forbidden without prior written consent of ABB.

Copyright© 2016 ABB  
All rights reserved

3AJUA0000142014 REV D EN 07.06.2016