

# GAS PRESSURE REGULATORS CATALOG

2<sup>nd</sup> EDITION





**⚠ WARNING**

**Service and installation must be performed by a trained/experienced service technician.**

All products used with combustible gas **must** be installed and used **strictly** in accordance with the instructions of the Original Equipment Manufacturer (OEM) and with all applicable government codes and regulations, e.g. plumbing, mechanical, and electrical codes and practices. Maxitrol products should be installed and operated in accordance with Maxitrol Safety Warning Instructions.

Maxitrol Company is NOT responsible for any errors or omissions in reliance by anyone of any information set forth in this catalog without additional reference to local requirements and applicable ordinances or codes.

**Other worldwide approvals and certifications available upon inquiry.**



# GF SERIES

## Gas and Air Filters

**G**as and air filters protect downstream controls (regulators, automatic shut-off valves) from particulate contamination. Recommended for use upstream of fittings, regulators, and controls. Applications for the residential, commercial cooking, process heating, and industrial burner industries.



**GF60**

## Specifications

<b>Pipe Sizes</b> .....	1/2" to 2" threaded connections with NPT or ISO7-1 threads.
<b>Housing Material</b> .....	GF40, GF60, GF80: aluminum.
<b>Mounting</b> .....	Suitable for multi-positional mounting, preferably with lid facing down or to the side to facilitate removal of debris during maintenance. <b>NOTE:</b> All Maxitrol gas filters should be installed and operated in accordance with Maxitrol Safety Warning Instructions (see GF_IO_EN.DE).
<b>Certifications</b> .....	According to DIN 3386, Gas Appliances 2009/142/EC and Pressure Equipment Directive 97/23/EEC.
<b>Gas Types</b> .....	Suitable for natural, manufactured, mixed gases, liquefied petroleum gases, LP gas-air mixtures, sewer gas, and air.
<b>Pressure Tap Connector</b> .....	Optional: Pressure tap (PF10) connections inlet and/or outlet side.
<b>Maximum Inlet Pressure</b> .....	15 psi (400 kPa)
<b>Ambient Temperature Ranges</b> .....	-4 to 175°F (-20 to 80°C)
<b>Storage and Transport Temp</b> .....	-58 to 175°F (-50 to 80°C)
<b>Filter Replacement</b> .....	GF40 Models: part number 101706-1 GF60 Models: part number 101706-2 GF80 Models: part number 101706-3



## Dimensions

NPT Model	ISO 7-1 Model	Pipe Size	Pressure
GF40-44	GF40M-44	1/2"	100 kPa, 400 kPa
GF60-66	GF60M-66	3/4"	100 kPa, 400 kPa
GF60-88	GF60M-88	1"	100 kPa, 400 kPa
GF80-1010	GF80M-1010	1 1/4"	100 kPa, 400 kPa
GF80-1212	GF80M-1212	1 1/2"	100 kPa, 400 kPa
GF80-1616	GF80M-1616	2"	100 kPa, 400 kPa

Outer Dimensions				
Model	Swing Radius	A	B	C
GF40	1.6" (41 mm)	2.1" (53 mm)	2.7" (69 mm)	2.3" (58 mm)
GF60	2.6" (66 mm)	3.7" (94 mm)	4.3" (109 mm)	3.7" (94 mm)
GF80	4" (102 mm)	6.2" (158 mm)	6.2" (163 mm)	6.4" (163 mm)

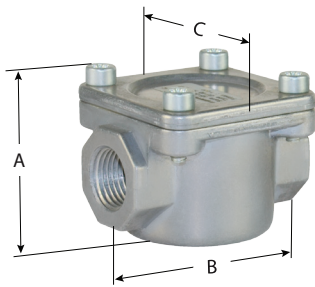

GF40

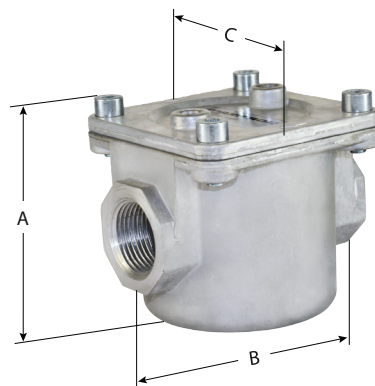

GF60

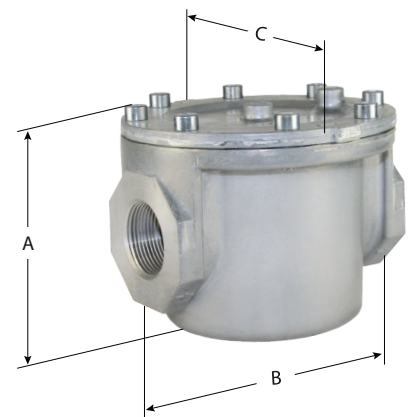

GF80

# GF1000 SERIES

## Gas and Air Filters

**G**as and air filters protect downstream controls (regulators, automatic shut-off valves) from particulate contamination. Recommended for use upstream of fittings, regulators, and controls. Applications for the residential, commercial cooking, process heating, and industrial burner industries.

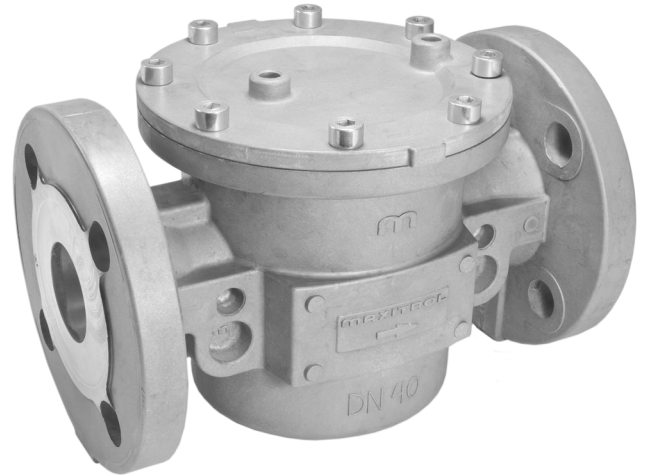

**GF1000MF40**

## Specifications

<b>Pipe Sizes</b> .....	DN40, DN50, DN65. ASME/ANSI Class 125, 1 1/2" to 2 1/2" flanged. Contact Maxitrol Company for availability.
<b>Housing Material</b> .....	Aluminum.
<b>Mounting</b> .....	Suitable for multi-positional mounting, preferably with lid facing down or to the side to facilitate removal of debris during maintenance. <b>NOTE:</b> All Maxitrol gas filters should be installed and operated in accordance with Maxitrol Safety Warning Instructions (see GF_IO_EN.DE).
<b>Certifications</b> .....	According to CE0085AQ0979
<b>Gas Types</b> .....	Suitable for natural, manufactured, mixed gases, liquefied petroleum gases, LP gas-air mixtures, sewer gas, and air.
<b>Pressure Tap Connector</b> .....	Optional: Pressure tap (PF10) connections inlet and/or outlet side.
<b>Maximum Inlet Pressure</b> .....	87 psi (600 kPa)
<b>Ambient Temperature Ranges</b> .....	-4 to 175°F (-20 to 80°C)
<b>Storage and Transport Temp</b> .....	-58 to 175°F (-50 to 80°C)
<b>Filter Replacement Kit</b> .....	KT-GF1000MF



## Dimensions

Model	Pipe Size	Pressure
GF1000MF40	DN40	100 kPa, 400 kPa, 600 kPa
GF1000MF50	DN50	100 kPa, 400 kPa, 600 kPa
GF1000MF65	DN65	100 kPa, 400 kPa, 600 kPa
GF1000F40	1 1/2"	100 kPa, 400 kPa, 600 kPa
GF1000F50	2"	100 kPa, 400 kPa, 600 kPa
GF1000F65	2 1/2"	100 kPa, 400 kPa, 600 kPa

Outer Dimensions			
Model	A	B	C
GF1000MF40, GF1000F40	6.2" (157 mm)	9.2" (234 mm)	6.1" (155 mm)
GF1000MF50, GF1000F50	6.6" (168 mm)	9.2" (234 mm)	6.1" (155 mm)
GF1000MF65, GF1000F65	7.4" (188 mm)	9.2" (234 mm)	6.1" (155 mm)

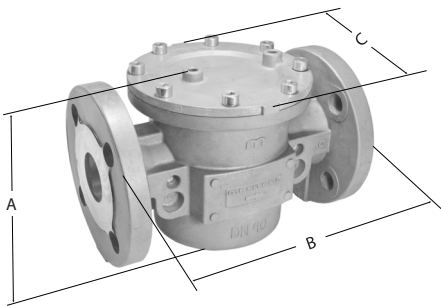

**GF1000MF40**

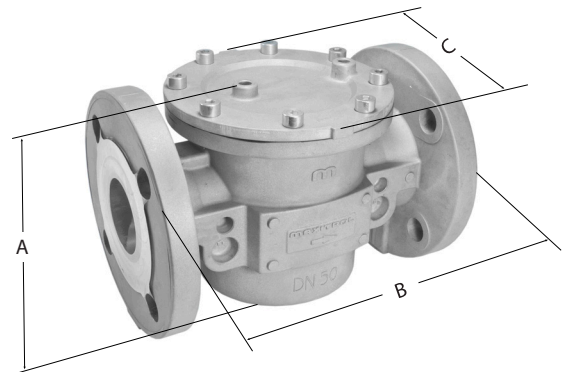

**GF1000MF50**

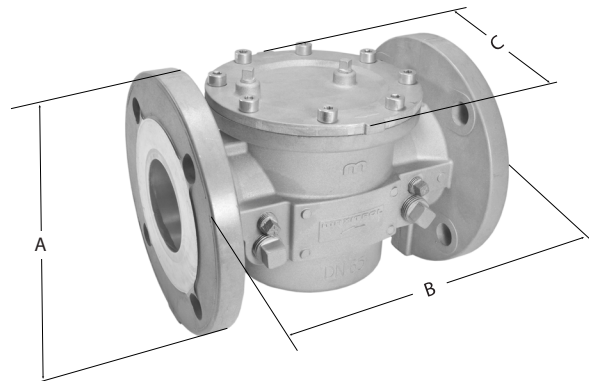

**GF1000MF65**

