

## Technical Datasheet

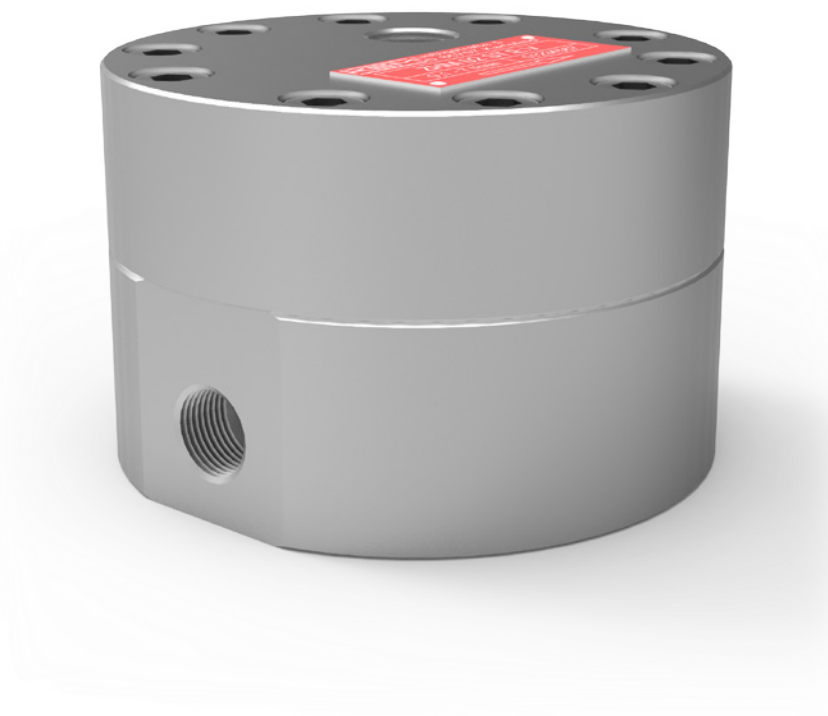

## ZHM ST Series

### Gear Flow Meters

for lubricating, non lubricating, abrasive and  
corrosive fluids

## Description

The ZHM ST gear flow meter series (ST for standard design) are flow meters which are mainly used in lubrication and non-lubrication liquids. They are equally suitable for filled, viscous and abrasive media.

Only high-grade steels that even withstand corrosive liquids are used in the production of gear flow meters. Combined with the use of tungsten carbide bearings, the ZHM ST guarantees optimum measurement accuracy and a long service life under even the toughest application conditions.

The combination of various gear dimensions and modules allows a wide range of sizes that can cover a huge measuring range. This makes the ZHM ST ideal for a variety of applications in the field of metering as well as for monitoring, mixing and dosing.

Short response times, very dynamic performance and high measurement accuracy ensure accurate regulation and control of flow rates in demanding applications.

For applications in hazardous areas, we offer intrinsically safe sensors and amplifiers with Ex protection in accordance with ATEX, IECEx, CSA and other standards. Additional certifications such as EAC (TR-CU) are available.

## Principle and Design

Gear flow meters (ZHM) are positive displacement meters. Two precise gears rotate freely inside the measuring chamber.

Sealed cavities are created between the gears and the housing. The measured media causes the rotation of the gears. The flowing medium is distributed evenly in the measuring chamber and causes the rotation of the gears. The gear wheels rotate freely and undamped in the media flow. Their rotational frequency is proportional to the flow rate and is measured by non-intrusive sensors (pick-ups) through the housing wall.

The sensor system can be variably adjusted to meet the requirements of the application. This allows, for example, providing even very high resolutions or also a signal for determining the direction of flow.

Pulses per unit of volume are available for analysis. The calibration factor (K-factor) of the flow meter describes the exact pulse rate per unit of volume. In order to determine the individual calibration factor of a flow meter, we calibrate each of our meters in house prior to delivery. The operating viscosity specified by the customer is taken into account for calibration. A corresponding calibration certificate is included with every flow meter we supply.

These meters are suitable for accurate measurement of different liquids with viscosities of approximately 1 to 25,000 mm<sup>2</sup>/s. For low-viscosity media and fuels gear wheel flow meters with ball bearings and reduced tolerances are used.

Thanks to a high output frequency, excellent resolution and short response times, our gear wheel flow meters are outstanding for measuring pulsing flows, for consumption measurement and for dosing of liquids.

## Applications

- Filling process
- Dosing systems
- 2-component and 3-component mixing plants
- Test stands
- Lubrication monitoring
- Consumption measurement
- Water-based paints, two component paints, highly filled metallic paints and Softfeel paints
- Preservative waxes, adhesives, PVC, epoxy resins, filled and abrasive media
- Polyol and isocyanate
- Oils, grease
- Hydraulic fluids and coolant
- Fuels, additives of any kind

## Features

- High measuring accuracy up to  $\pm 0.1\%$ <sup>1)</sup>
- Exceptional repeatability of  $\pm 0.05\%$
- Measuring range up to 1:400
- Short response times
- Pressure-resistant up to 630 bar
- Medium temperature up to 356 °F (180 °C)
- Robust construction and long lifetime
- Explosion protection EExiaIICT4 or T6 for Zone 1
- Applicable for electrostatic/ESTA applications

<sup>1)</sup> Under laboratory conditions; incl. linearization; viscosity  $\geq 30$  mm<sup>2</sup>/s.

## Technical Data - Sizes

ZHM Type <sup>2)</sup>	Measuring Range (l/min)			K-Factor <sup>3)</sup> (Impulse/l)	max. Pressure (bar)	Frequency <sup>3)</sup> (Hz)			Weight (kg)
ZHM 01	0.005	to	1	41,000	630	3.4	to	680	1.3
ZHM 01/1	0.005	to	2	26,500	630	2.2	to	880	1.3
ZHM 01/2	0.02	to	3	14,000	630	4.6	to	700	1.6
ZHM 02/1	0.05	to	2	8,200	630	6.8	to	273	2.1
ZHM 02	0.1	to	7	4,200	630	7	to	490	2.2
ZHM 03	0.5	to	25	1,740	630	14	to	730	2.9
ZHM 04	0.5	to	70	475	630	4	to	560	8.5
ZHM 05	5	to	150	134	400	11	to	340	23
ZHM 06/1	5	to	250	106	400	8.8	to	450	27
ZHM 06	10	to	500	53	400	18	to	450	35
ZHM 07	50	to	1,000	24	400	20	to	400	66.5

## Technical Data - General

Measuring Accuracy	Up to $\pm 0.1\%$ <sup>4)</sup>
Repeatability	$\pm 0.05\%$ (under the same conditions)
Linearity	$\pm 0.5\%$ of actual flow (viscosity $\geq 30$ mm <sup>2</sup> /s)
Materials	Housing: as per DIN 1.4305 (AISI 303), 1.4404 (AISI 316L) Wheels: as per DIN 1.4122, 1.4501 (AISI F55) Bearing: Tungsten carbide Seals: FKM, PTFE, FFKM, NBR, EPDM
Medium Temperature	-4 °F up to +356 °F (-20 °C up to +180 °C) (other temperatures on request)
Dimensions	See dimensional drawing (page 4 to 5)



<sup>2)</sup> Exact type designation on request.

<sup>3)</sup> Average values for single sensors, dual pickups and higher resolution available.

<sup>4)</sup> Under laboratory conditions; incl. linearization; viscosity  $\geq 30$  mm<sup>2</sup>/s.

## Dimensional Drawing - ZHM 01 to 05

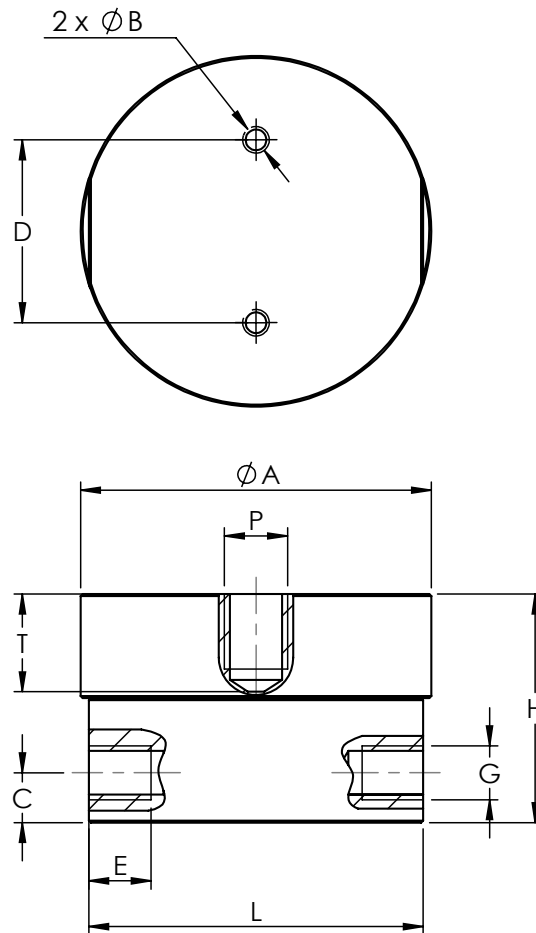

ZHM Type	$\phi A$	B	C	D	E	G <sup>5)</sup>	H	L	P <sup>6)</sup>	T <sup>6)</sup>
ZHM 01	2.99 in (76 mm)	M6 $\nabla$ 10	0.41 in (10.5 mm)	1.73 in (44 mm)	0.55 in (14 mm)	G 1/4", M12x1.5	1.61 in (41 mm)	2.83 in (72 mm)	M14x1.5	0.75 in (19 mm)
ZHM 01/1	2.99 in (76 mm)	M6 $\nabla$ 10	0.41 in (10.5 mm)	1.73 in (44 mm)	0.55 in (14 mm)	G 1/4", M12x1.5 1/4" NPT	1.85 in (47 mm)	2.83 in (72 mm)	M14x1.5	0.71 in (18 mm)
ZHM 01/2	2.99 in (76 mm)	M6 $\nabla$ 10	0.47 in (12 mm)	1.73 in (44 mm)	0.55 in (14 mm)	G 1/4", M12x1.5 1/4" NPT	1.97 in (50 mm)	2.83 in (72 mm)	M14x1.5	0.71 in (18 mm)
ZHM 02	3.32 in (84.4 mm)	M6 $\nabla$ 10	0.47 in (12 mm)	1.73 in (44 mm)	0.55 in (14 mm)	G 1/4", M12x1.5 1/4" NPT	2.17 in (55 mm)	3.17 in (80.5 mm)	M14x1.5	0.93 in (23.5 mm)
ZHM 02/1	3.32 in (84.4 mm)	M6 $\nabla$ 10	0.47 in (12 mm)	1.73 in (44 mm)	0.55 in (14 mm)	G 1/4", M12x1.5	2.01 in (51 mm)	3.17 in (80.5 mm)	M14x1.5	0.93 in (23.5 mm)
ZHM 03	3.32 in (84.4 mm)	M6 $\nabla$ 10	0.47 in (12 mm)	1.73 in (44 mm)	0.55 in (14 mm)	G 1/4", M12x1.5	2.64 in (67 mm)	3.17 in (80.5 mm)	M14x1.5	0.93 in (23.5 mm)
ZHM 04	4.92 in (125 mm)	M6 $\nabla$ 10	0.67 in (17 mm)	2.36 in (60 mm)	0.71 in (18 mm)	G 1/2", M20x1.5 1/2" NPT	3.78 in (96 mm)	4.76 in (121 mm)	M14x1.5	1.20 in (30.5 mm)
ZHM 05	6.91 in (175.5 mm)	M8 $\nabla$ 15	0.89 in (22.5 mm)	3.94 in (100 mm)	0.71 in (18 mm)	G 1", M33x2	5.24 in (133 mm)	6.69 in (170 mm)	M14x1.5	1.71 in (43.5 mm)

<sup>5)</sup> Others on request.

<sup>6)</sup> Only applies for single pickup holes of type „E“.

Attention: the total installation height is the result of the height (H) and the height of the electronics (dimensions in separate datasheet).

## Dimensional Drawing - ZHM 06/1 to 07

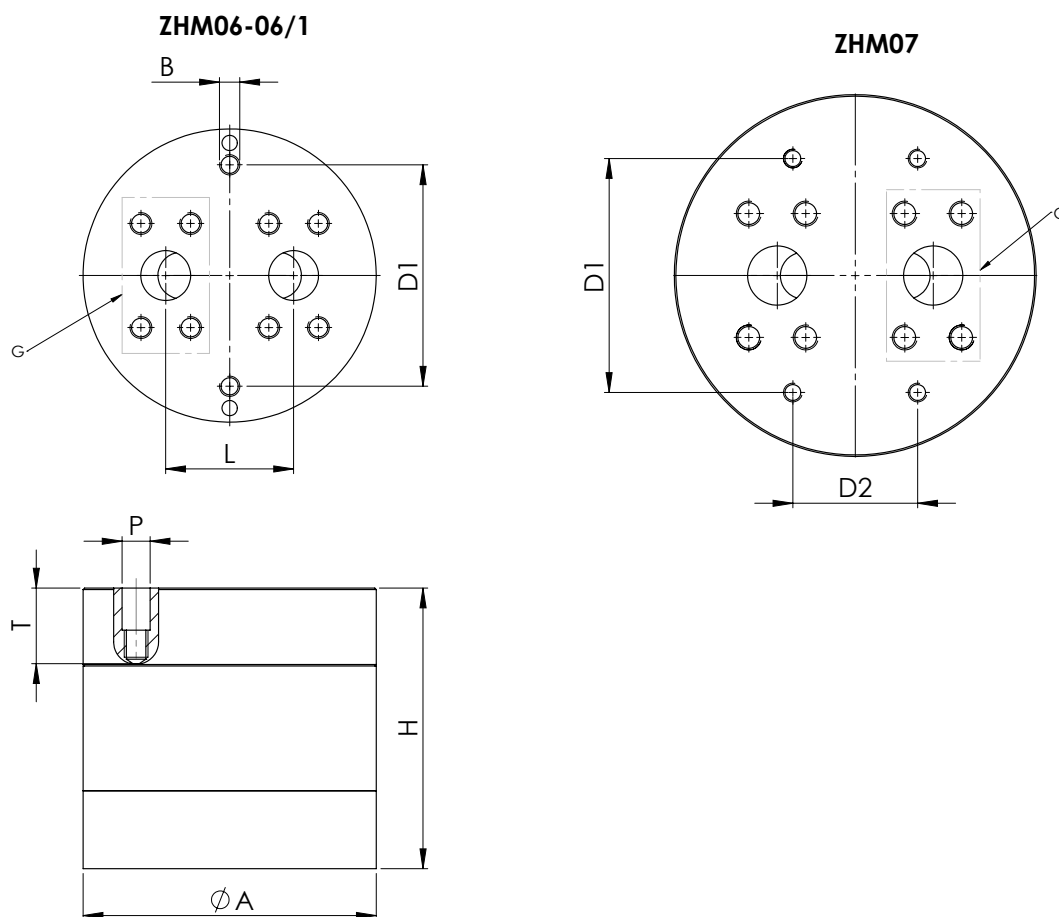

ZHM Type	Ø A	B	D1	D2	G	H	L	P <sup>7)</sup>	T <sup>7)</sup>
ZHM 06/1	7.42 in (188.5 mm)	M12 ∇ 25	5.59 in (142 mm)	-	SAE 1¼" ISO 6162-2	5.43 in (138 mm)	3.23 in (82 mm)	M14x1.5	1.91 in (48.5 mm)
ZHM 06	7.42 in (188.5 mm)	M12 ∇ 25	5.59 in (142 mm)	-	SAE 1¼" ISO 6162-2	7.09 in (180 mm)	3.23 in (82 mm)	M14x1.5	1.89 in (48 mm)
ZHM 07	9.17 in (233 mm)	M12 ∇ 25	5.90 in (150 mm)	3.15 in (80 mm)	SAE 1½" ISO 6162-2	8.66 in (220 mm)	3.94 in (100 mm)	M14x1.5	2.48 in (63 mm)

<sup>7)</sup> Only applies for single pickup holes of type „E“.   
 Attention: the total installation height is the result of the height (H) and the height of the electronics (dimensions in separate datasheet).

## Calibration

In-house calibration is performed on volumetric calibration rigs or at the wishes of the customer in our DAkkS calibration laboratory.

The KEM calibration lab uses a high-precision load cell system. With an accuracy of 0.05 % for the mass and 0.1 % for the volume of flowing liquids, we occupy a leading position worldwide. The German Accreditation Body (DAkkS) has accredited the laboratory with engineers, processes and measuring equipment in accordance with the international standard DIN EN ISO/IEC 17025:2005.

The KEM calibration certificate not only verifies the accuracy of a flow meter, but also guarantees its traceability to national standards as well as ensuring all requirements according to international quality standards are met.

The calibrations are performed with different hydrocarbons. This ensures the optimum simulation of changing operating conditions in density and viscosity even when temperatures change. This way the primary viscosity for the use of the flow meter can be specifically taken into account when viscosity fluctuations occur in a customised application.

The calibration result is the specified calibration factor (K-factor) in pulses per litre. This K-factor accordingly applies only at a certain flow velocity or a certain flow rate.

The calibration factor varies only very slightly at different volume flow rates. The individual measuring points provide the calibration curve of the flow meter from which the average K-factor is determined. The average calibration factor applies to the entire measuring range.

The linearity error specification (percentage deviation) refers to the average K-factor. To further increase the measurement accuracy in onsite use, the specific K-factors can be used to calculate the flow rate. For this, KEM also supplies optional special electronics.

## Calculation of volume flow

The flow is directly dependent on the measured frequency and the associated calibration factor:

$$Q = \frac{f \cdot 60}{K} \text{ l/min}$$

Q = Volume Flow  
f = Measuring frequency  
K = Specific K-Factor

## Calibration protocol

Example: ZHM 02 ST (0.1 to 7 l/min)

