









IR HYDRAULIC WORK SUPPORTS







IR

HYDRAULIC WORK SUPPORTS

CYLINDER TYPE		IR12.250	IR16S	IR16.2	IR16.0	IR25.0	IR25.1	IR32	IR40
SINGLE ACTING	Threaded type 	M22x1.5	M26X1.5	M30x1.5	M30x1.5	M42x1.5	M42x1.5	M50x1.5	/
500 BAR	Cartridge 	/	/	/	/	/	/	Yes	/
CYLINDER BODY TYPE	Upper flange 	/	/	/	/	/	/	Yes	/
	Lower flange 	/	/	/	/	/	/	/	Yes
Version with hydraulic approach		Yes	Yes	Yes	Yes	Yes	Yes	Yes	Yes
Normally extended (spring approach)		Yes	Yes	Yes	Yes	Yes	Yes	Yes	Yes
Metal wiper (option)		Yes	Yes	Yes	Yes	Yes	Yes	Yes	Yes
Rod diameter (mm)		12	16	16	16	25	25	32	40
Total cylinder stroke (mm)		4.5	6.5	9.7	8	8	13	12	18
Maximum operating pressure (Bar)		250	350	400	400	400	400	400	400
Supporting force at 200 Bar (KN)*		1.6	2	1.8	3	5.9	10.5	13.5	14.5

CYLINDER TYPE		IRFP16 SD	IR16.8 D/LD	IR16.15 D/LD	IR25.8	IR25.13
DOUBLE ACTING	Threaded type 	M26x1.5	M30x1.5	M30x1.5	M42x1.5	M42x1.5
500 BAR	Cartridge 	/	/	/	/	/
CYLINDER BODY TYPE	Upper flange 	/	/	/	/	/
	Lower flange 	/	/	/	/	/
Version with hydraulic approach		Yes	Yes	Yes	Yes	Yes
Normally extended (spring approach)		No	No	No	No	No
Metal wiper (option)		Yes	Yes	Yes	Yes	Yes
Rod diameter (mm)		16	16	16	25	25
Total cylinder stroke (mm)		6.5	8	15	8	13
Maximum operating pressure (Bar)		350	400	400	400	400
Supporting force at 200 Bar (KN)*		2	1.8/3	1.8/3	5.9	10.5

CYLINDER TYPE		IR10.70	IR12.70	IRFP15.70
SINGLE ACTING	Threaded type 	M26X1.5	M30x1.5	M36x1.5
70 BAR	Cartridge 	/	/	/
CYLINDER BODY TYPE	Upper flange 	/	/	/
	Lower flange 	/	/	/
Version with hydraulic approach		Yes	Yes	Yes
Normally extended (spring approach)		Yes	Yes	Yes
Metal wiper (option)		Yes	Yes	Yes
Rod diameter (mm)		10	12	15
Total cylinder stroke (mm)		6.5	8	8
Maximum operating pressure (Bar)		70	70	70
Supporting force at 70 Bar (KN)*		3	4	5.5

* = SEE CORRESPONDING DIAGRAM



HYDROBLOCK

COMPARATIVE DIAGRAM WITH THE PERFORMANCE OF WORK SUPPORTS AS A FUNCTION OF THE OPERATING PRESSURE

Hydraulic work supports offer efficient workpiece support during machining and compensate vibrations and deflections of the workpiece. In addition, they align themselves to complex workpieces in clamping operations that require more than three clamping points. If the spherical pressure pad needs to be replaced for application-specific reasons, please contact HYDROBLOCK for technical details on the work support in question.

NOTE: If a workpiece is clamped on the work support, the supporting force F must be at least twice as high as the clamping force generated by the clamping cylinder. We generally recommend operating work supports with high pressures in order to ensure efficient supporting capacity.

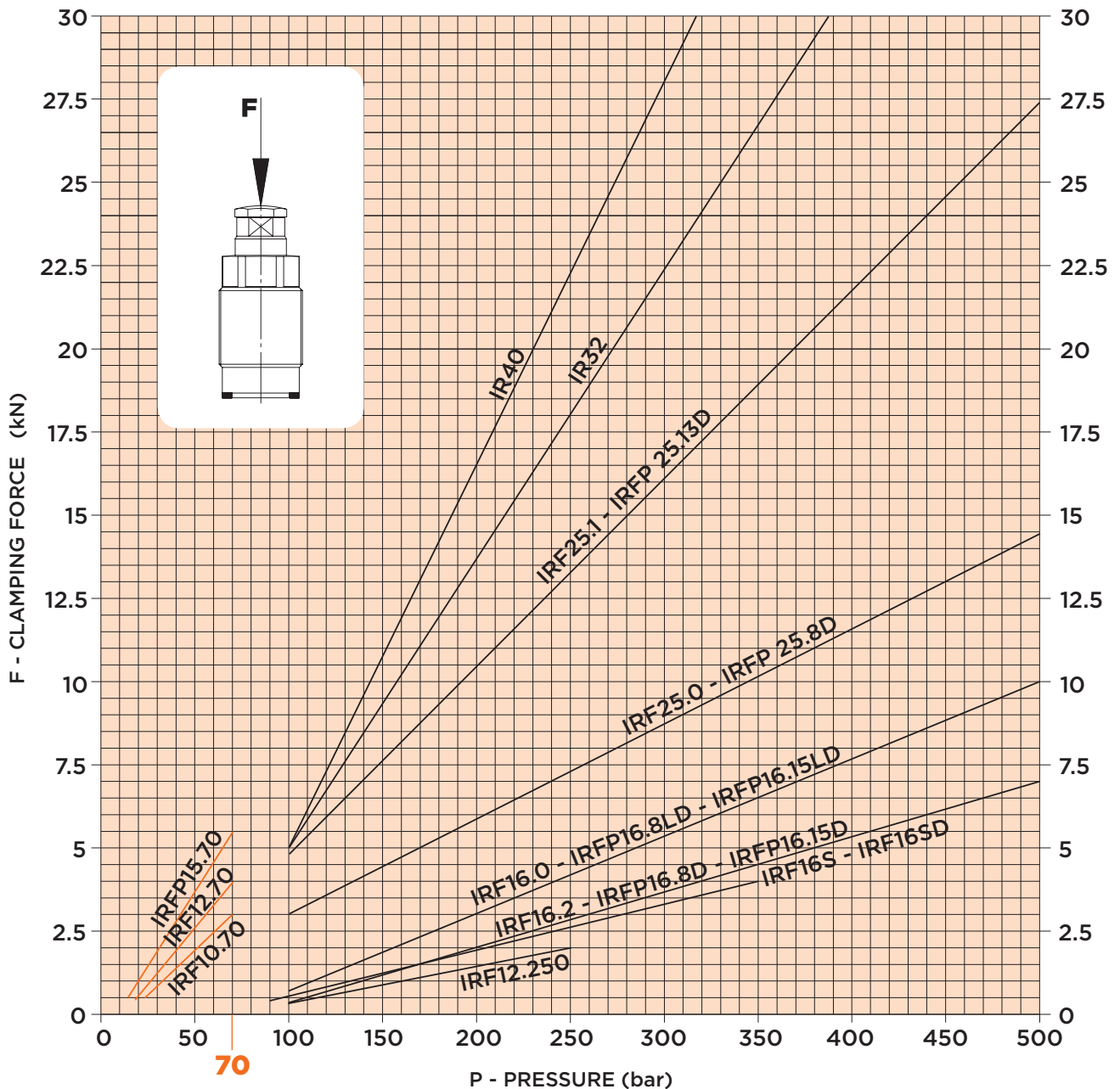

APPLICATION EXAMPLES

Typical applications of hydraulic work supports:

- 1) Use as workpiece support during machining
- 2) Use as additional forth clamping point with upper clamp arm

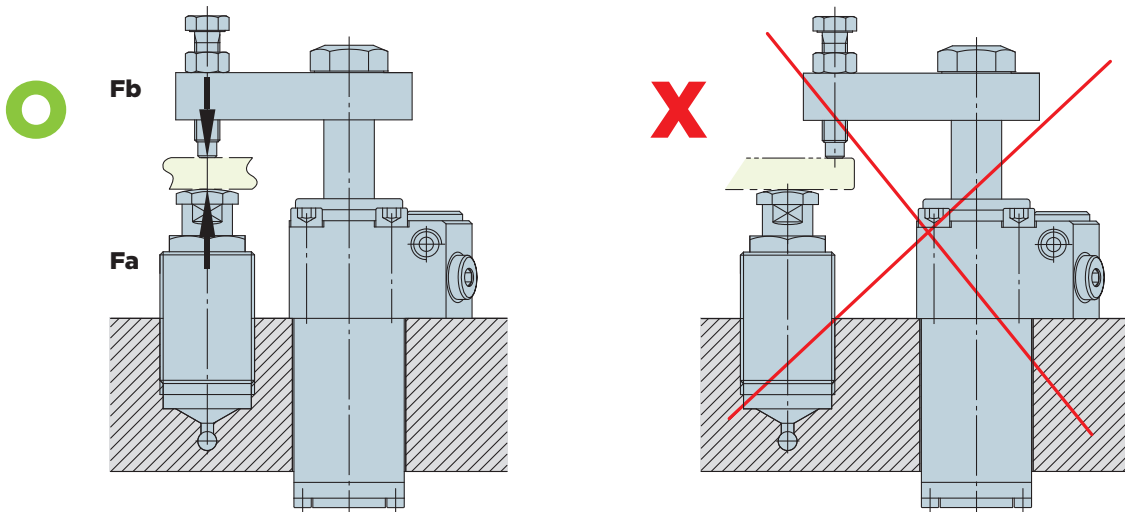
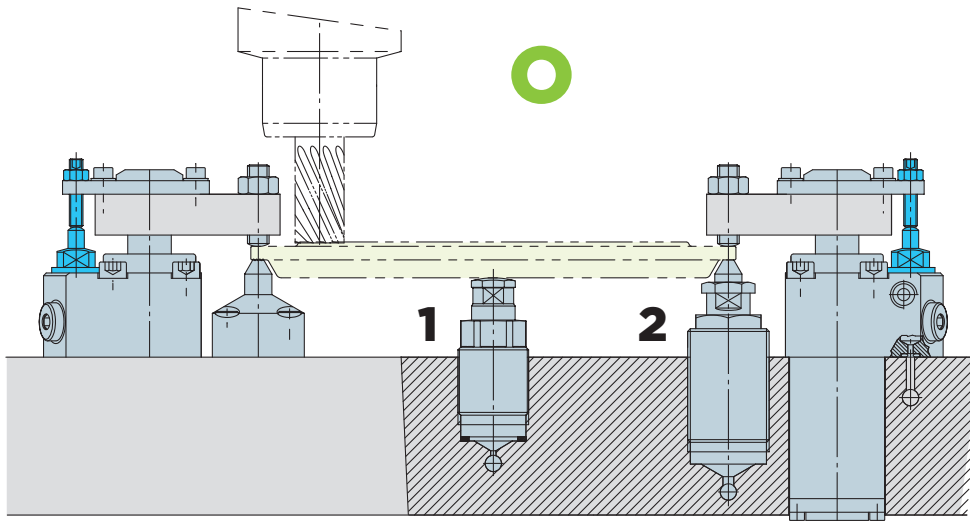

$F_b = 1/2 F_a$ MAX.

In standard supporting applications, the ratio between the work support force and the force exerted on the workpiece F_a/F_b should be 2:1.

For applications with particularly extreme conditions, e.g. with high vibrations during machining, we recommend increasing the ratio to 3:1 or more. In any case, the force exerted on the workpiece **MUST** act coaxially to the pressure pad of the hydraulic work support.



APPLICATION EXAMPLES

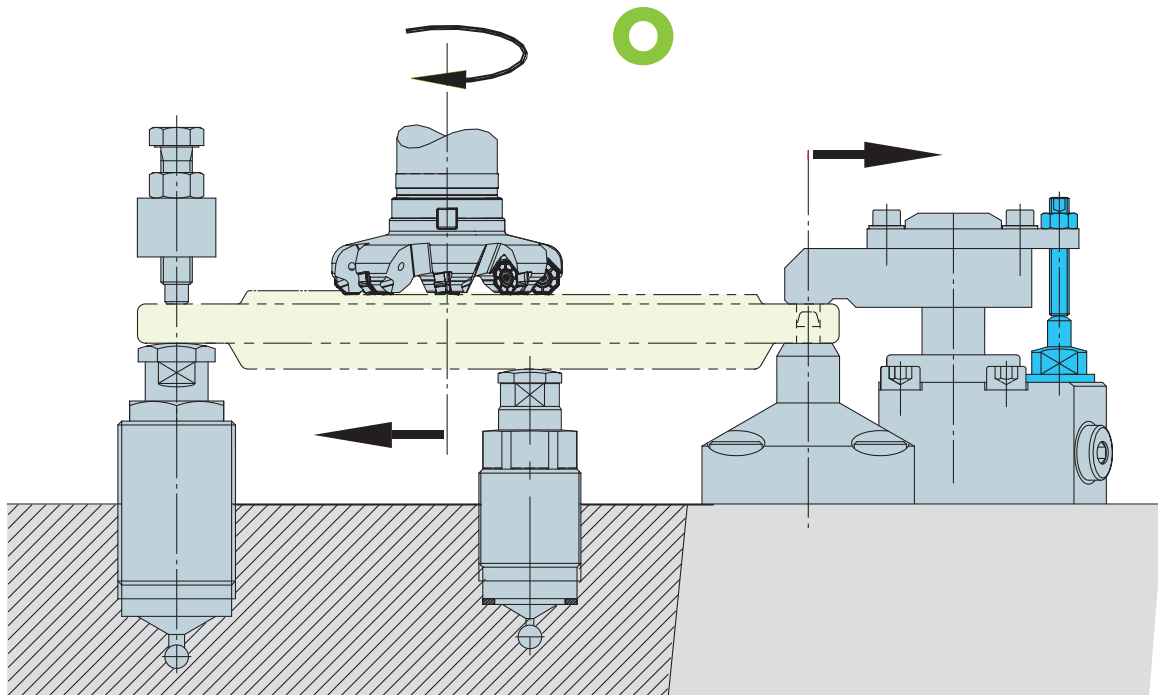
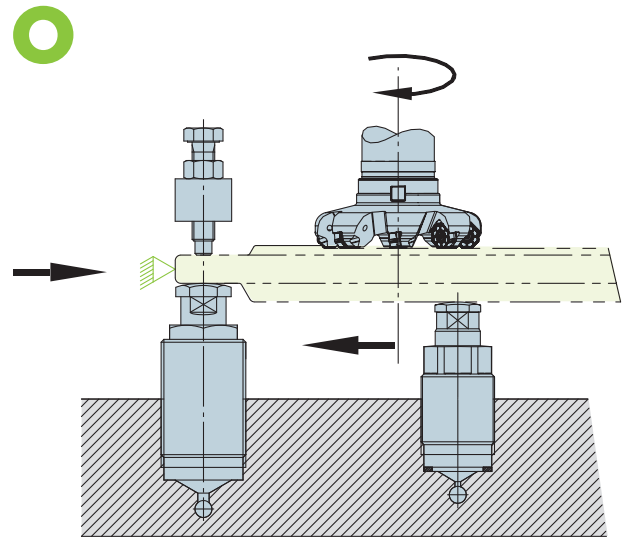
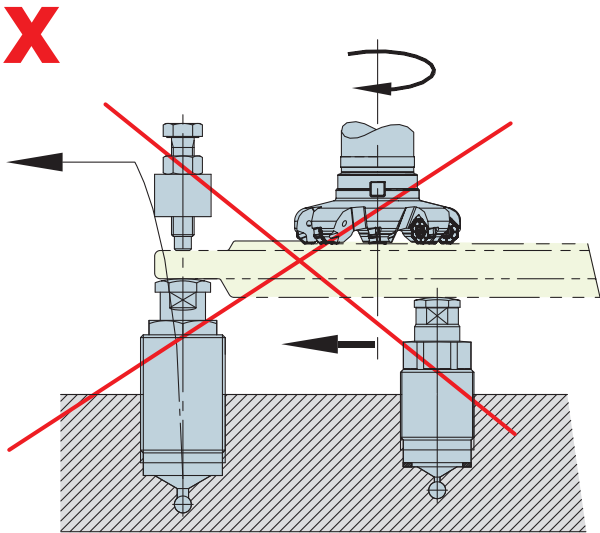

APPLICATION EXAMPLES

If the cylinder is provided with a vent port, this opening must be PROTECTED against the penetration of pressurized emulsified water and/or chips. Small profiled tubes may be used for this purpose as they allow the cylinder to “breathe”, which avoids the rising of fluids. The vent ports should not be provided in positions above the cylinder axis (fig. 1) as in the event of sudden rising of contaminated fluids inside the cylinder, the fluids would remain in the internal chambers and inevitably affect the functional properties.

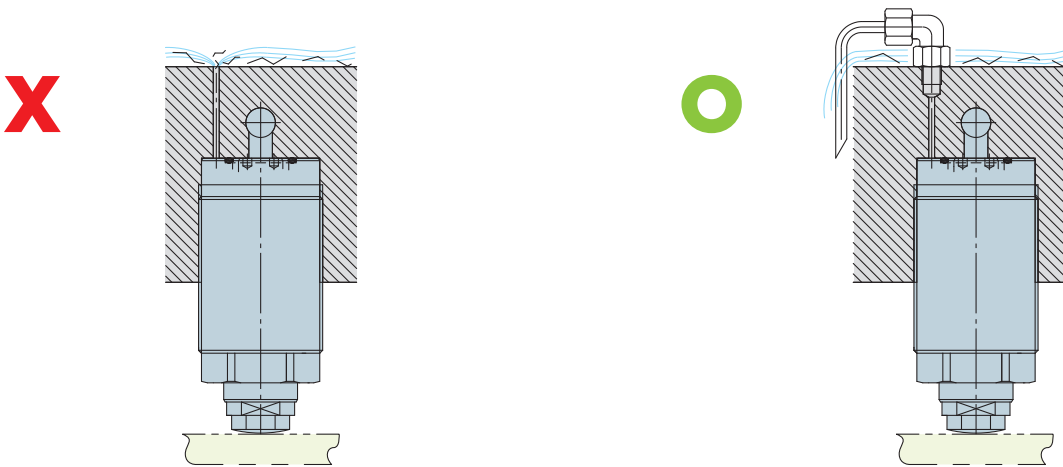
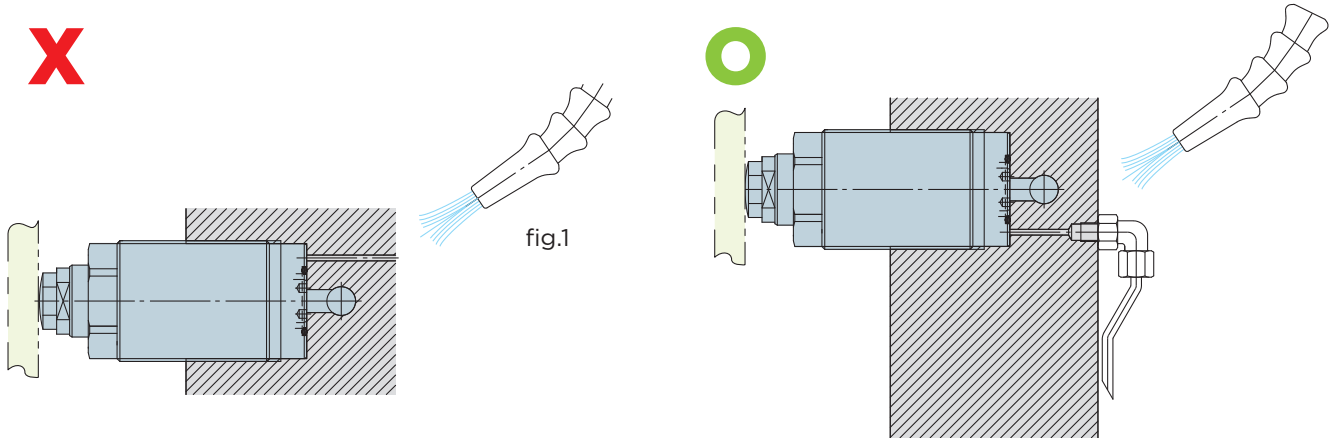

Do not install the cylinders with the body being completely inserted in an excessively deep seat: the cavity would be filled with emulsified water and chips and the cylinder would be damaged by fluid absorption and/or by chips being pressed against the rod wiper. If the cylinder partly remains outside the seat, the guiding system will be cleaned by the emulsified water flow.

NOTE: In the case of immersed applications, the cylinder must be purged on a regular basis.

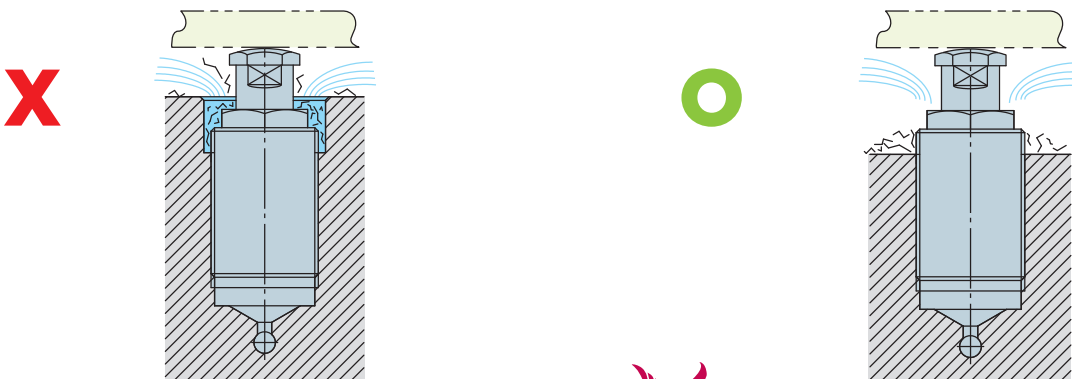

APPLICATION EXAMPLES

- 1) Maximum distance to the workpiece:** In this case, there is a minimum force exerted by the work support on the clamped workpiece. The correct function of the cylinder could be influenced by the operating environment and/or by contamination due to machining residues. This solution is particularly suitable for work supports used in applications where the cylinder is subjected to high forces during machining.
- 2) Minimum distance to the workpiece:** In this case, there is a maximum force exerted by the work support on the clamped workpiece. The function is extremely reliable and affected to a minor extent only by the operating environment, contamination or chips. There is a strong contact with the workpiece so that the solution is particularly suitable as forth clamping point. The ideal position is below the clamp arm. A minimum ratio of 2:1 between the supporting force/cylinder clamping force should be observed.

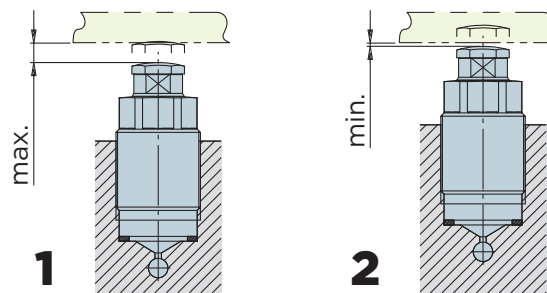

MOUNTING INSTRUCTIONS

The mounting instructions relative to the seats must be strictly observed in order to ensure perfect operation of the work supports, i.e. the venting channel must be clean and pneumatic pressurization must be ensured, where provided. The indicated work support force is the maximum axial force the cylinder can reliably generate repetitively in the long run. The cylinder must only be subjected to coaxial stress, as radial forces could affect correct positioning and operation of the work support. **Any radial forces MUST be absorbed by the fixture.** If the **pressure pad** needs to be replaced by a customized version, the installation dimensions indicated for the relevant work support must be strictly observed. Make sure that the tailor-made pressure pad does **NOT exceed the weight of the original pressure pad by more than 100%** in order not to jeopardize the correct operation of the work support and to ensure proper approach to the workpiece.

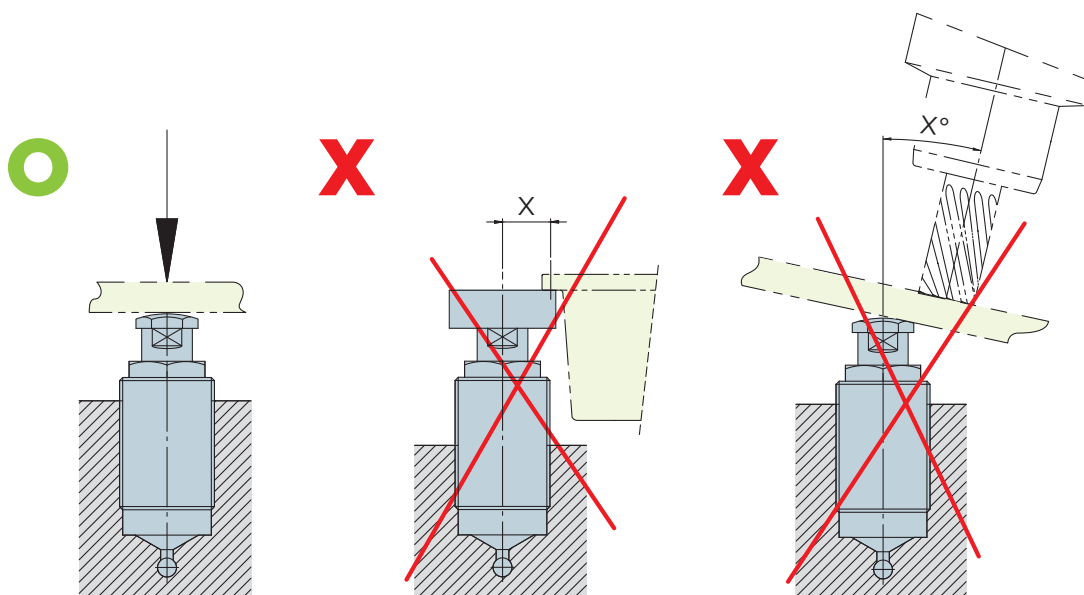

IR HYDRAULIC WORK SUPPORTS

MOUNTING:

The hydraulic circuit must be properly purged and vented to ensure smooth operation of the work supports. Slightly pressurize the system for this purpose. If possible, venting can be performed more easily and rapidly by using the bleed screws provided at the top of the fixture or close to the hydraulic line ends.

SUPPLY:

Make sure that the supply flow is below the maximum admissible flow rate to achieve perfect operation of the hydraulic work supports. Excessively high flow rates will cause irregular function of the supporting bolts, i.e. they will be blocked prior to reaching the maximum stroke or they are approached too fast. The workpiece can thus not be reliably supported and may be deformed.

VENTING (IF PROVIDED):

The cylinder will only operate correctly if the pneumatic line is free and protected against the penetration of fluids, dirt and chips. IR work supports generate a pressure increase in the inside during operation. If no proper venting is ensured, fluids, dust and chips may be sucked in. We recommend pressurizing the cylinder chamber with filtered air at a low pressure (max. 0.2/0.3 bar) to achieve smooth operation of the work supports.

NOTE:

When the cylinder is pressurized, the approach force of the bolts and the workpiece deformation will increase. To minimize the deformation forces, a soft approach spring should be used for pressurizing.

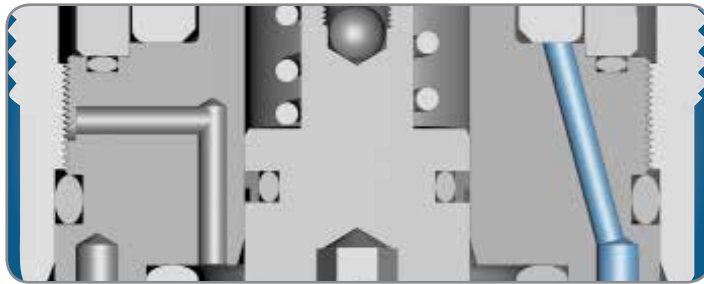

↑
- - - - -
Venting
(type-specific)

THRUST PAD:

All work supports are delivered with a pressure pad with spherical tip. If necessary, the pressure pads can be replaced, provided the technical specifications in the catalogue are observed. Pressure pads should feature minimum dimensions and weight to avoid cylinder malfunction and undesired workpiece deformation. Customized work supports can be delivered for pressure pads with special dimensions and weight.

NEVER USE the cylinders without thrust pad on the workpiece: fluids, dust or chips may penetrate into the cylinder and lead to substantial damage.



HIGH PRESSURE

CYLINDER IN P-VERSION (WITH HYDRAULIC APPROACH)

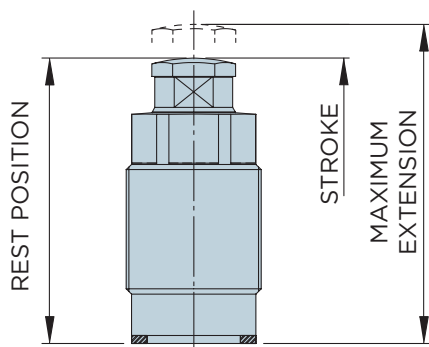

Operating mode in P-version:

In rest position, the supporting bolt is RETRACTED. When the hydraulic supply is switched on, the supporting bolt is extended until it reaches the clamped workpiece. The approach to the workpiece is performed by a spring that can be delivered with different spring forces for certain models. It must be observed that the approach force of the supporting bolt IS NOT constant throughout the cylinder stroke, but decreases as a function of the approach stroke.

With a very short approach stroke, the maximum force of the approach spring will be exerted on the workpiece. Vice versa, the clamped workpiece will be subjected to minimum spring approach forces in the case of a maximum approach stroke.

Operating mode in D-version:

DOUBLE-ACTING work supports are available for special applications in hydraulic circuits with high counter-pressures, which involve substantially longer times required for retracting single-acting cylinders or make retraction almost impossible. Please contact HYDROBLOCK for more detailed information.

CYLINDER IN M-VERSION (WITH MECHANICAL APPROACH)

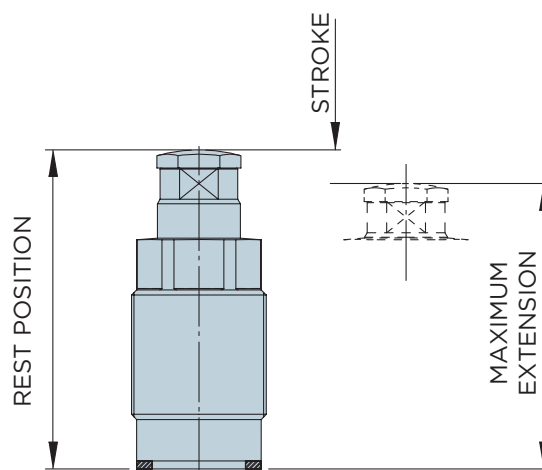

Operating mode in M-version:

In rest position, the supporting bolt is extended. The weight of the workpiece or the force generated by the clamp arm press the supporting bolt into clamping position. As soon as the hydraulic supply is activated, the supporting bolt is fixed in its position.

Contact with the workpiece is achieved by a spring that can be delivered with different spring forces for certain models. It must be observed that the thrust of the vibration-dampening supporting bolt IS NOT constant throughout the cylinder stroke, but decreases as a function of the bolt retraction. With a very short retraction stroke of the supporting bolt, a minimum spring force is exerted on the clamped workpiece.

Vice versa, the clamped workpiece will be subjected to the maximum approach spring force in the case of a maximum retraction stroke.



MOUNTING

HYDRAULIC WORK SUPPORTS

SERIES IRF

Before mounting IRF/IRC work supports, make sure that all preparations of the seat have been made in compliance with the technical catalogue. Insert the delivered O-ring/sealing ring up to the bottom into the seat or place it in the groove provided at the cylinder. Then tighten the cylinder with the specified torque using a socket wrench or a ring spanner. Do not use open-end wrenches for this purpose as they could damage the work support. **Flow control valves must be used for circuits with high flow rates.**

TIGHTENING TORQUES:

- M26X1,5 = 30Nm (IRF 10.70) • M26X1,5 = 45Nm (IRF 16S) • M30X1,5 = 50Nm (IRF 12.70)
- M30X1,5 = 60Nm (IRF 16/IRF 16.2) • M42X1,5 = 65Nm • M50X1,5 = 80Nm

NOTE:

We recommend using two wrenches when replacing the pressure pad of IRF/IRC work supports, i.e. one for fixing the piston rod and one for loosening the pressure pad from the cylinder and in particular for tightening it.

Do not work on the pressure pad when the work support is pressurized and the piston rod is fixed by the elastic sleeve as this could affect the operation of the cylinder.

IRF10.70

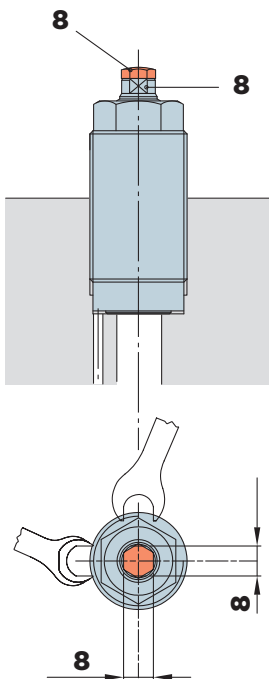

IRF12.70

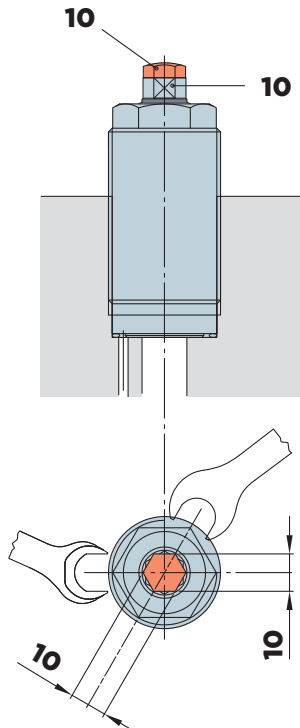

IRF15.70

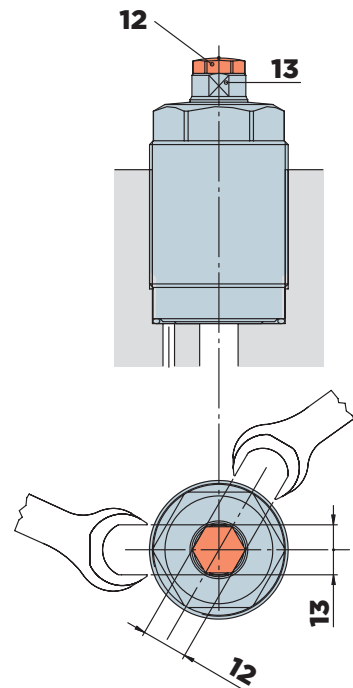

MOUNTING

HYDRAULIC WORK SUPPORTS

SERIES IRF

IRF12.250

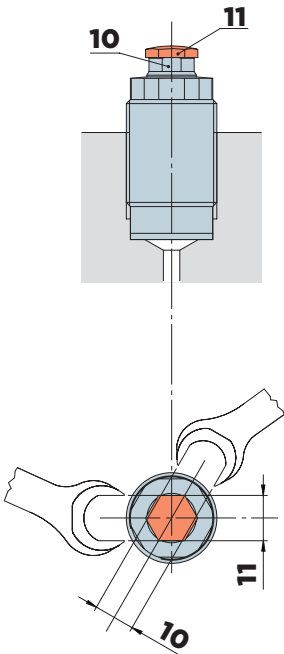

IRF16 S/SD

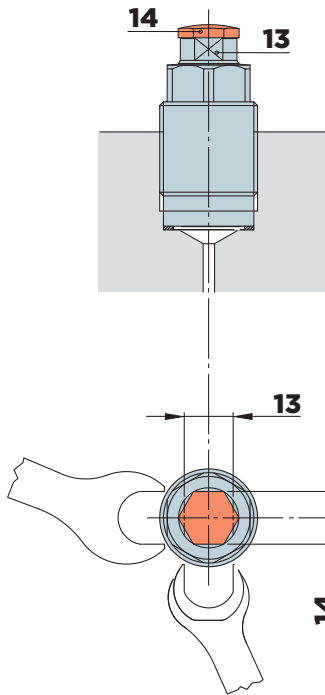

IRF16.0/16.2

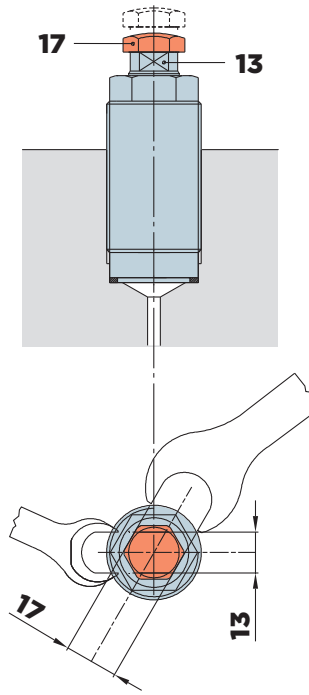

IRF16.8/16.15

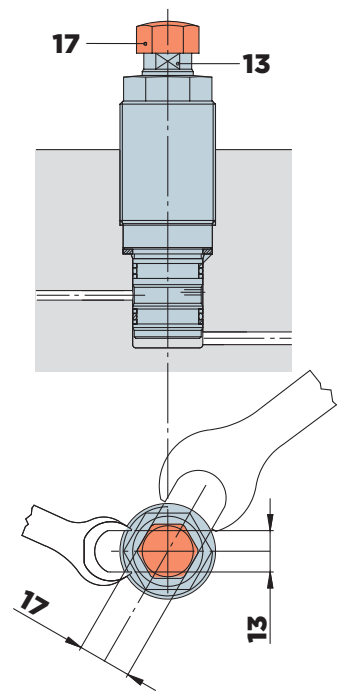

IRF25.0/25.1

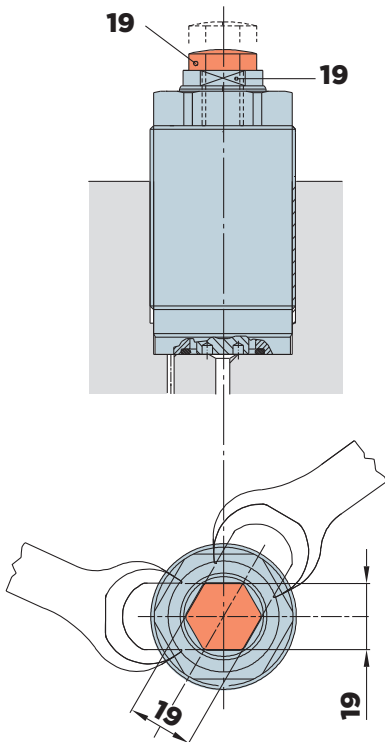

IRFP25.8/25.13

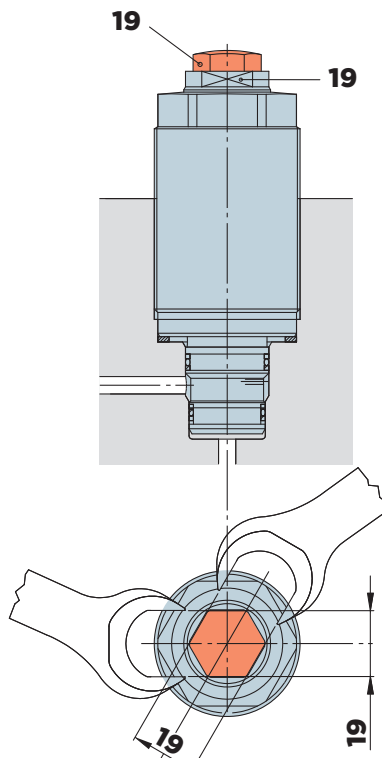

IR32.0

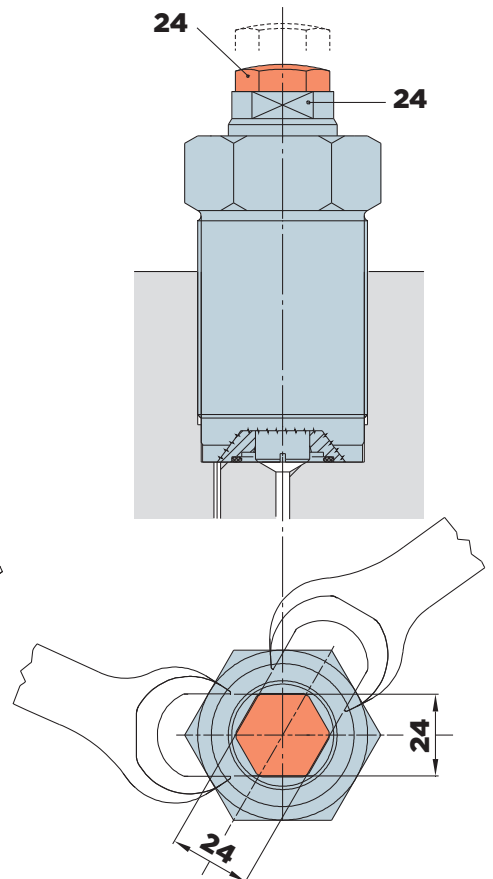

IR SINGLE-ACTING HYDRAULIC WORK SUPPORTS

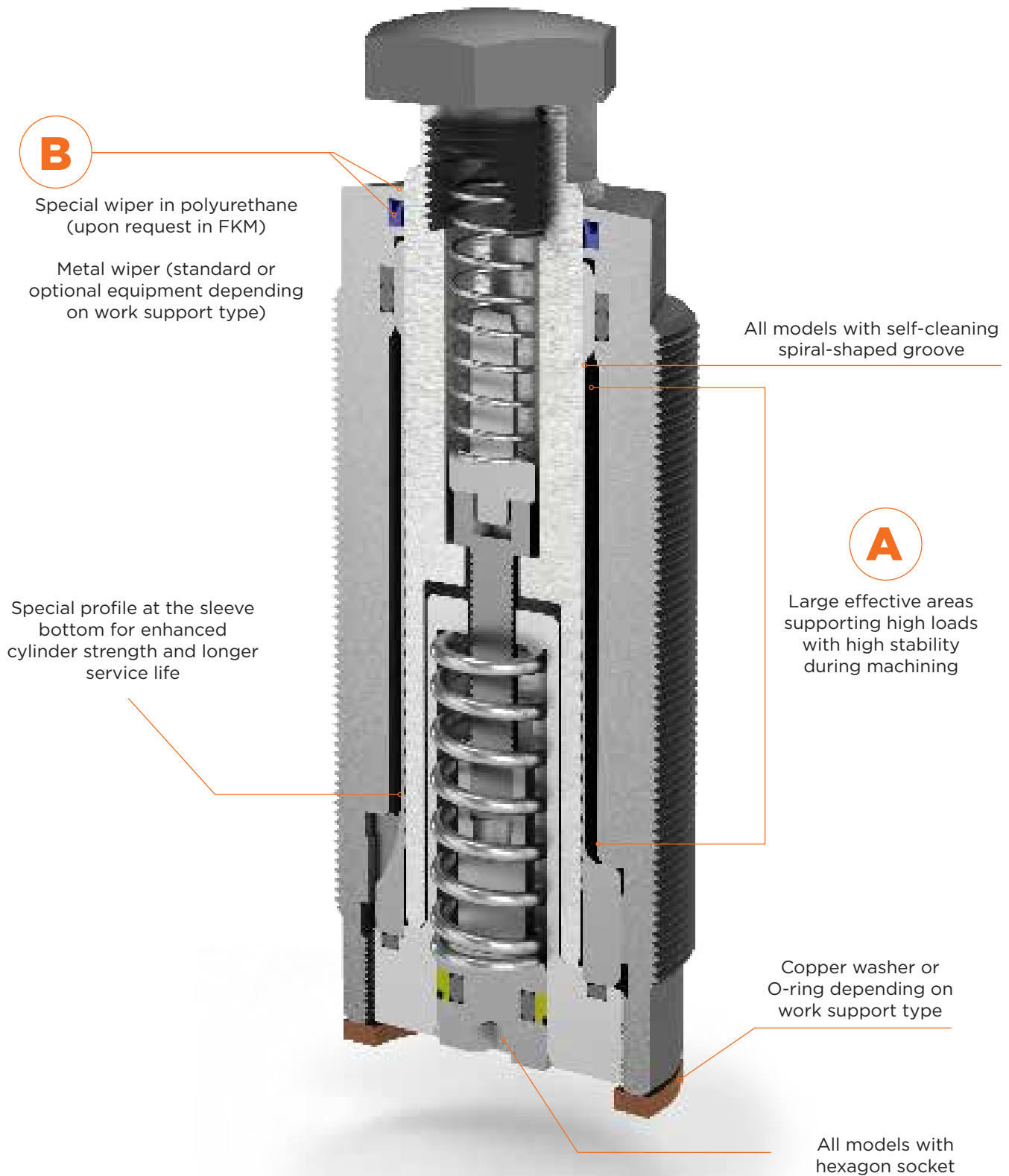

HIGH PRESSURE

A. CALIBRATED AND SELF-CLEANING ELASTIC SLEEVE

The supporting bolt is fixed by a special calibrated elastic sleeve that features thin walls.

With increasing hydraulic pressure, the cylindrical sleeve is deformed until it adheres to the cylinder bolt and produces a clamping force that is proportional to the applied pressure. The bolt is thus firmly fixed by friction.

When the clamping pressure decreases again, the sleeve assumes its original shape and the bolt is released.

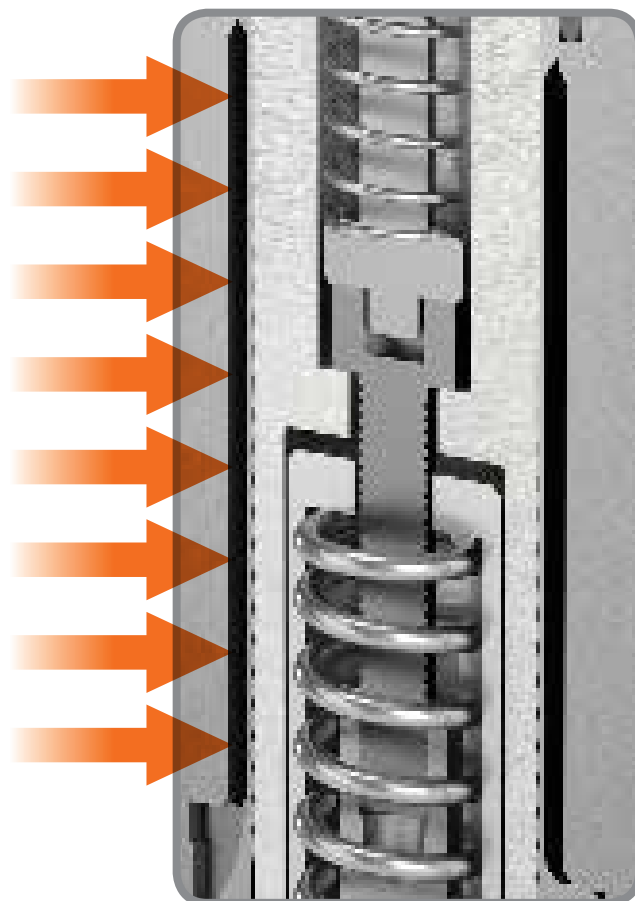

B. WIPER

Clean and smoothly running bolts are a fundamental prerequisite for perfect operation of the work supports. This is why the body is equipped with special low-friction wipers with lip profile.

Work supports with metal wipers are available for extreme operating conditions to protect the lip profile and to ensure a long service life of the cylinder.



METAL WIPER



STANDARD WIPER



IRFP 12.250

HYDRAULIC WORK SUPPORT WITH **THREADED BODY**

MAX. OPERATING PRESSURE = 250BAR

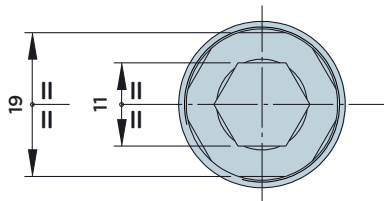
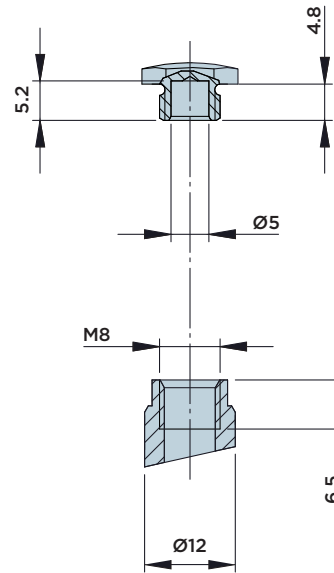
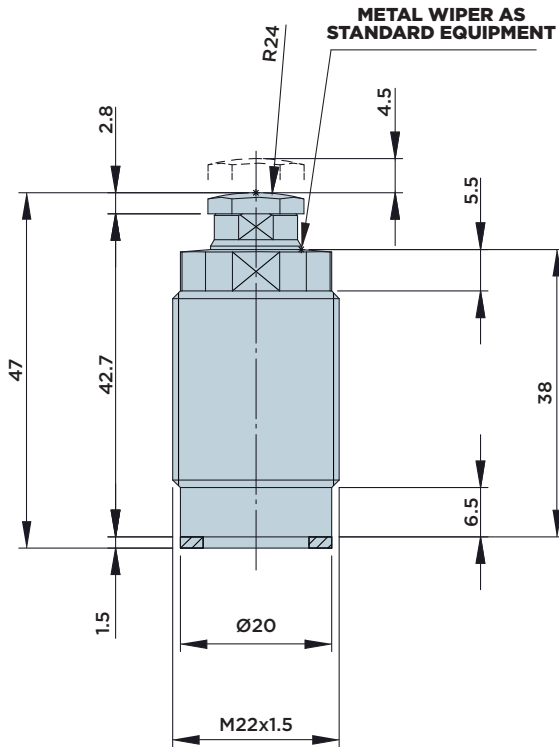
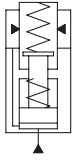

INSTALLATION DIMENSIONS

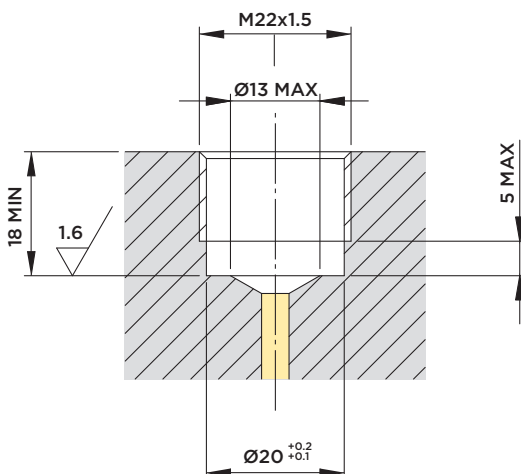

FORCE/PRESSURE/DEFLECTION DIAGRAM

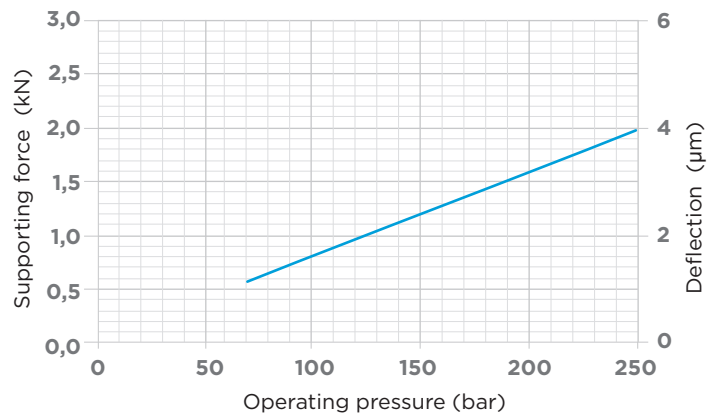

Note:

The maximum admissible flow rate amounts to 1.5 l/min.

Contact force:

- Standard 15÷25 N

Included in the scope of supply:

- Sealing ring Ø14xØ20x1.5

Material:

- Piston/rod: Case-hardened steel, ground.
- Body: Free machining steel, nitrocarburized.



HYDROBLOCK

IRFM 12.250

HYDRAULIC WORK SUPPORT WITH **THREADED BODY**

MAX. OPERATING PRESSURE = 250BAR

METAL WIPER AS STANDARD EQUIPMENT

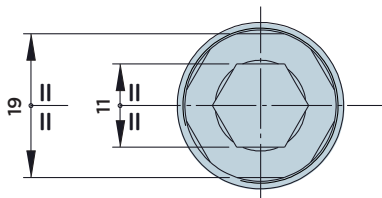
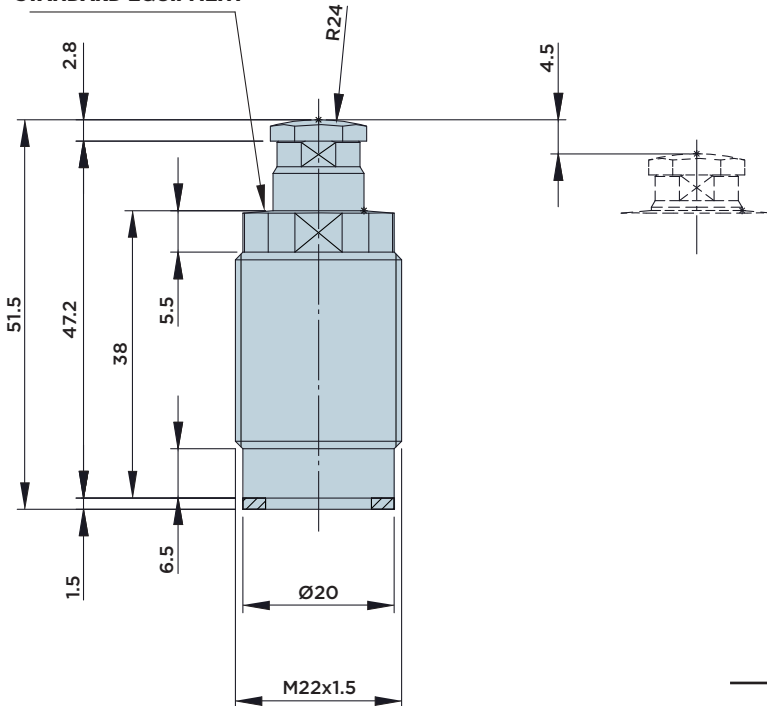

INSTALLATION DIMENSIONS

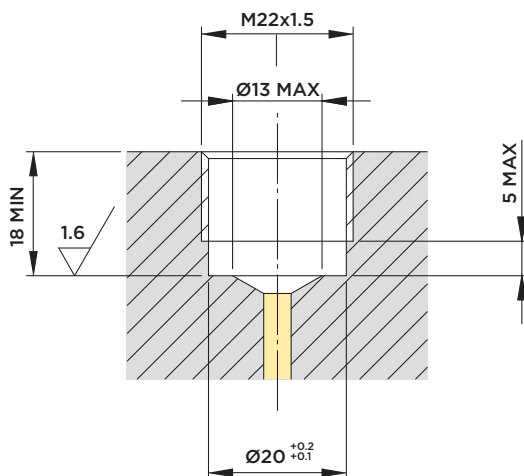

FORCE/PRESSURE/DEFLECTION DIAGRAM

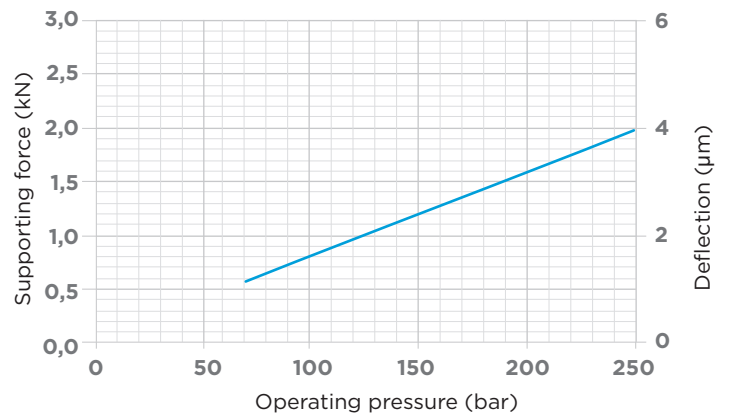

Note:

The maximum admissible flow rate amounts to 1.5 l/min.

Contact force:

- Standard 15÷25 N

Included in the scope of supply:

- Sealing ring Ø14xØ20x1.5

Material:

- Piston/rod: Case-hardened steel, ground.
- Body: Free machining steel, nitrocarburized.



HYDROBLOCK

IRFP 16S

HYDRAULIC WORK SUPPORT WITH **THREADED BODY**

MAX. OPERATING PRESSURE = 350BAR

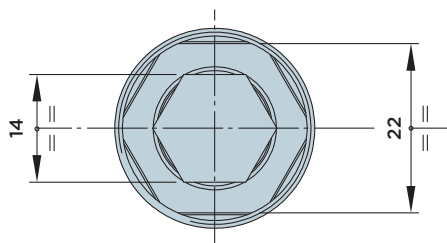
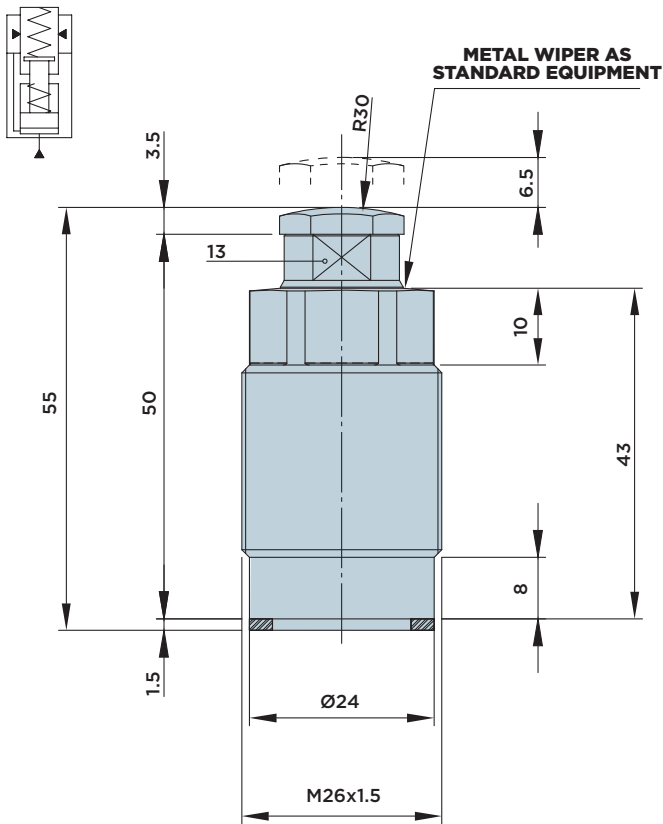

INSTALLATION DIMENSIONS

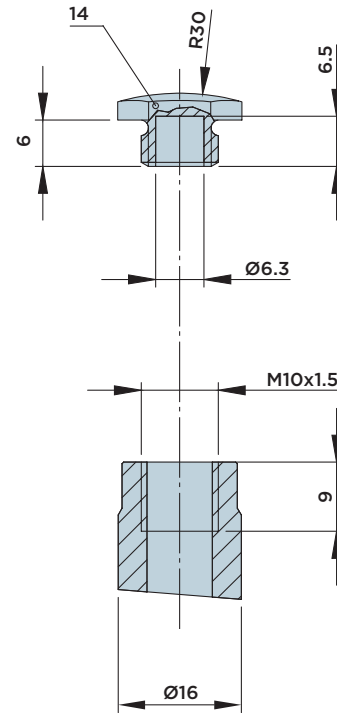
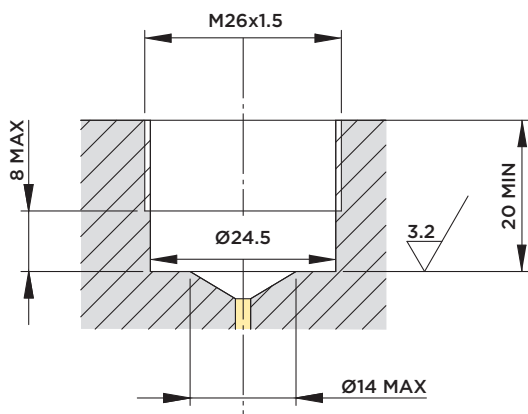

FORCE/PRESSURE/DEFLECTION DIAGRAM

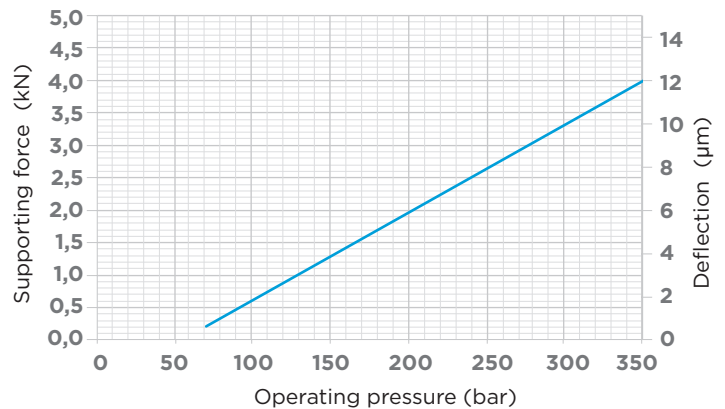

Note:

The maximum admissible flow rate amounts to 1.5 l/min.

Contact force:

- Standard 15÷25 N

Included in the scope of supply:

- Sealing ring Ø18xØ24x1.5

Material:

- Piston/rod: Case-hardened steel, ground.
- Body: Free machining steel, nitrocarburized.



HYDROBLOCK

IRFM 16S

HYDRAULIC WORK SUPPORT WITH **THREADED BODY**

MAX. OPERATING PRESSURE = 350BAR

METAL WIPER AS STANDARD EQUIPMENT

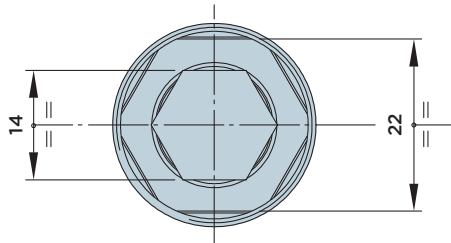
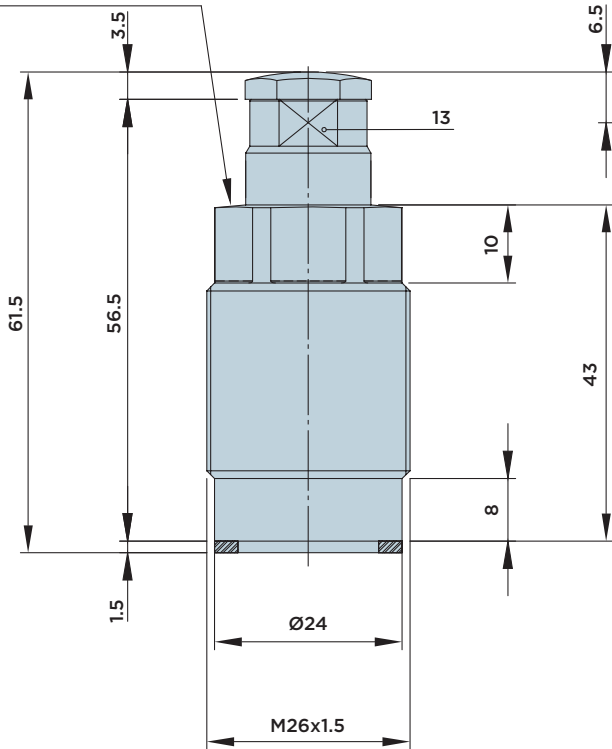

INSTALLATION DIMENSIONS

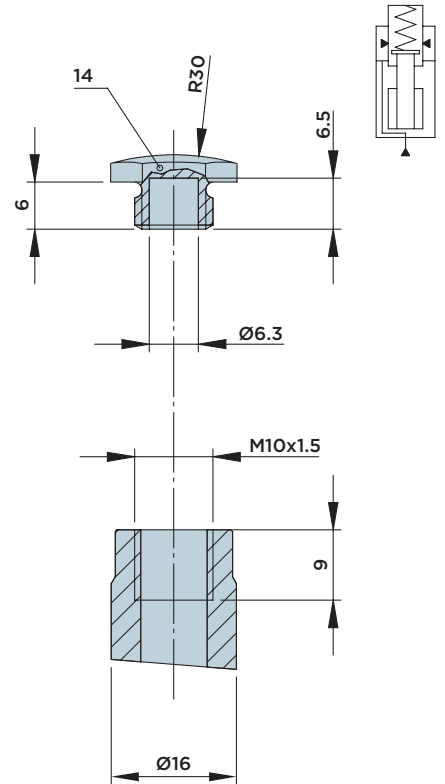
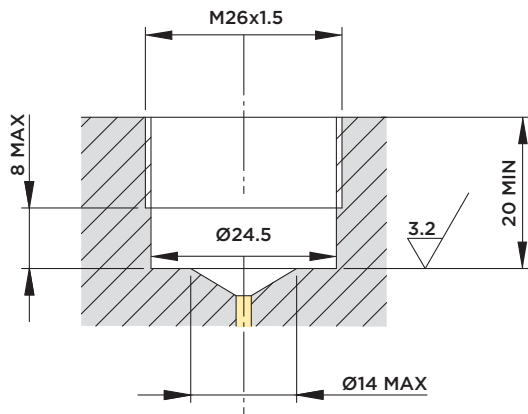

FORCE/PRESSURE/DEFLECTION DIAGRAM

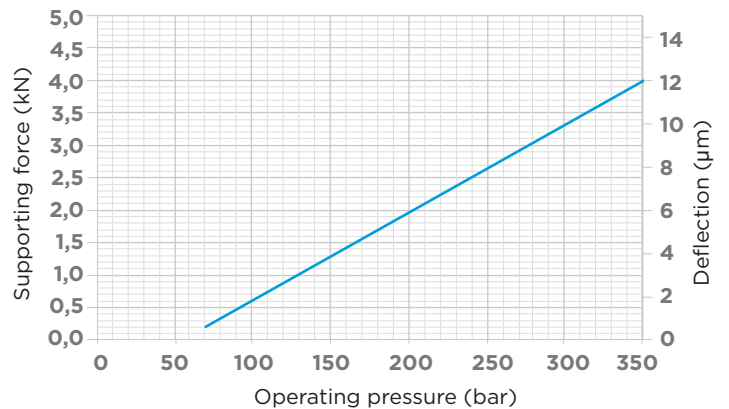

Note:

The maximum admissible flow rate amounts to 1.5 l/min.

Contact force:

- Standard 15÷25 N

Included in the scope of supply:

- Sealing ring Ø18xØ24x1.5

Material:

- Piston/rod: Case-hardened steel, ground.
- Body: Free machining steel, nitrocarburized.



HYDROBLOCK

IRFP 16.2

HYDRAULIC WORK SUPPORT WITH **THREADED BODY**

MAX. OPERATING PRESSURE = 500BAR

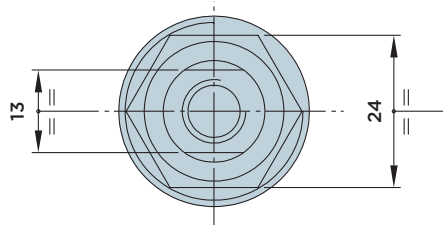
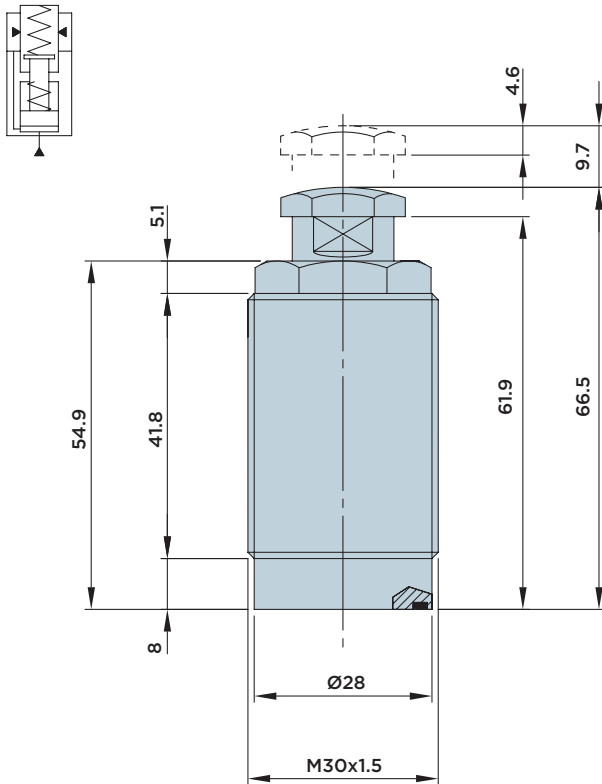

INSTALLATION DIMENSIONS

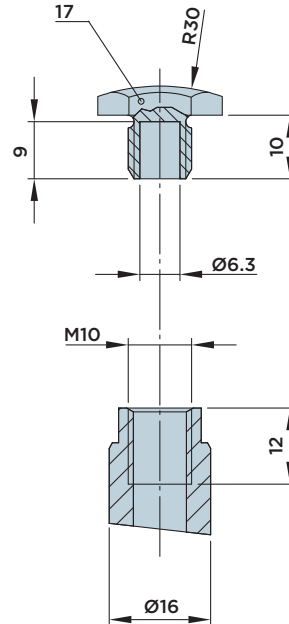
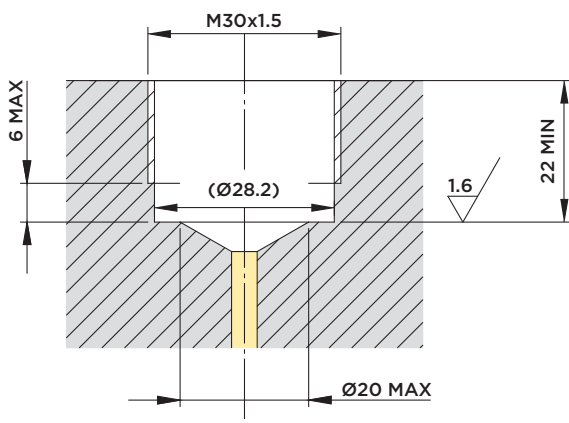

FORCE/PRESSURE/DEFLECTION DIAGRAM

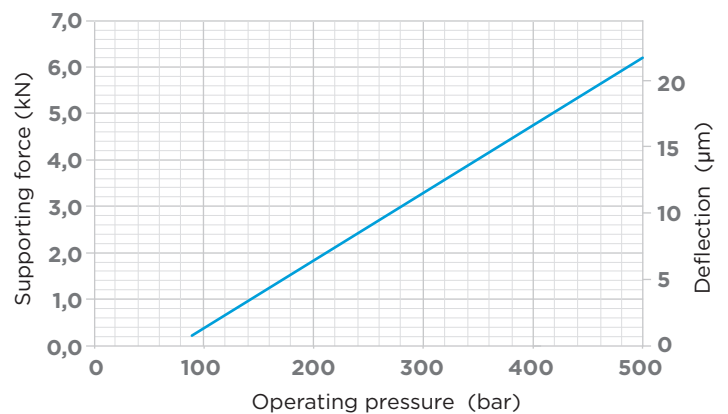

Note:

The maximum admissible flow rate amounts to 1.5 l/min.

Contact force:

- Standard 15÷30 N
- Upon request 8÷20 N (order no. IRFP16.2L)

Included in the scope of supply:

- Metric O-rings $\varnothing 23.5 \times 1.5$

Material:

- Piston/rod: Case-hardened steel, ground.
- Body: Free machining steel, nitrocarburized.



HYDROBLOCK

IRFM 16.2

HYDRAULIC WORK SUPPORT WITH **THREADED BODY**

MAX. OPERATING PRESSURE = 500BAR

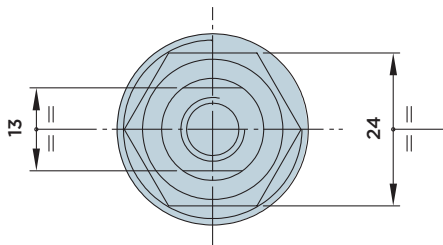
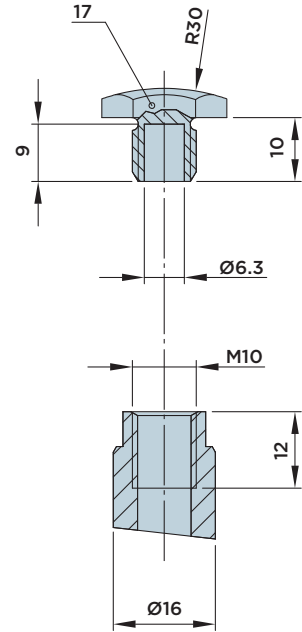
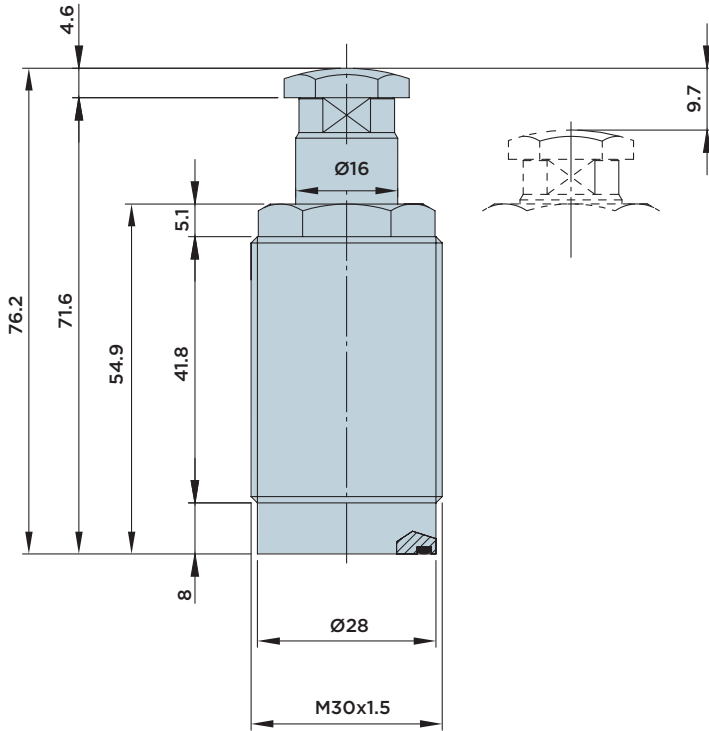

INSTALLATION DIMENSIONS

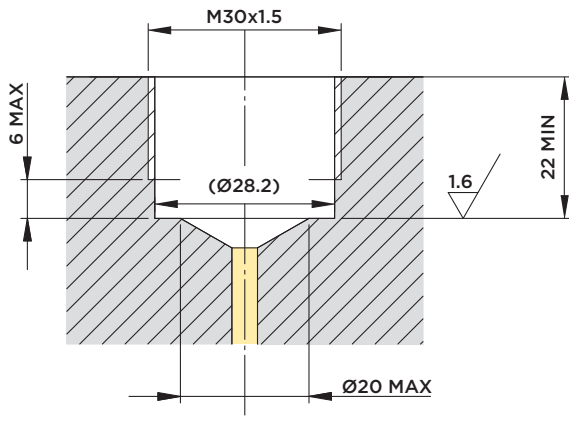

FORCE/PRESSURE/DEFLECTION DIAGRAM

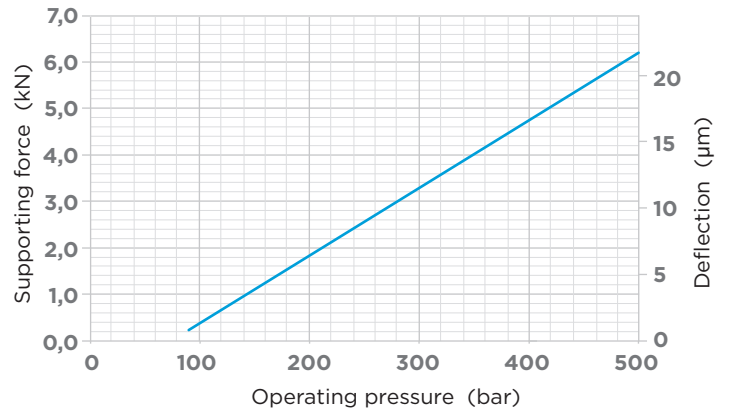

Note:

The maximum admissible flow rate amounts to 1.5 l/min.

Contact force:

- Standard 15÷30 N
- Upon request 8÷20 N (order no. IRFM16.2L)

Included in the scope of supply:

- O-ring Ø 23.5x1.5

Material:

- Piston/rod: Case-hardened steel, ground.
- Body: Free machining steel, nitrocarburized.



HYDROBLOCK

IRFP 16.0

HYDRAULIC WORK SUPPORT WITH **THREADED BODY**

MAX. OPERATING PRESSURE = 500BAR

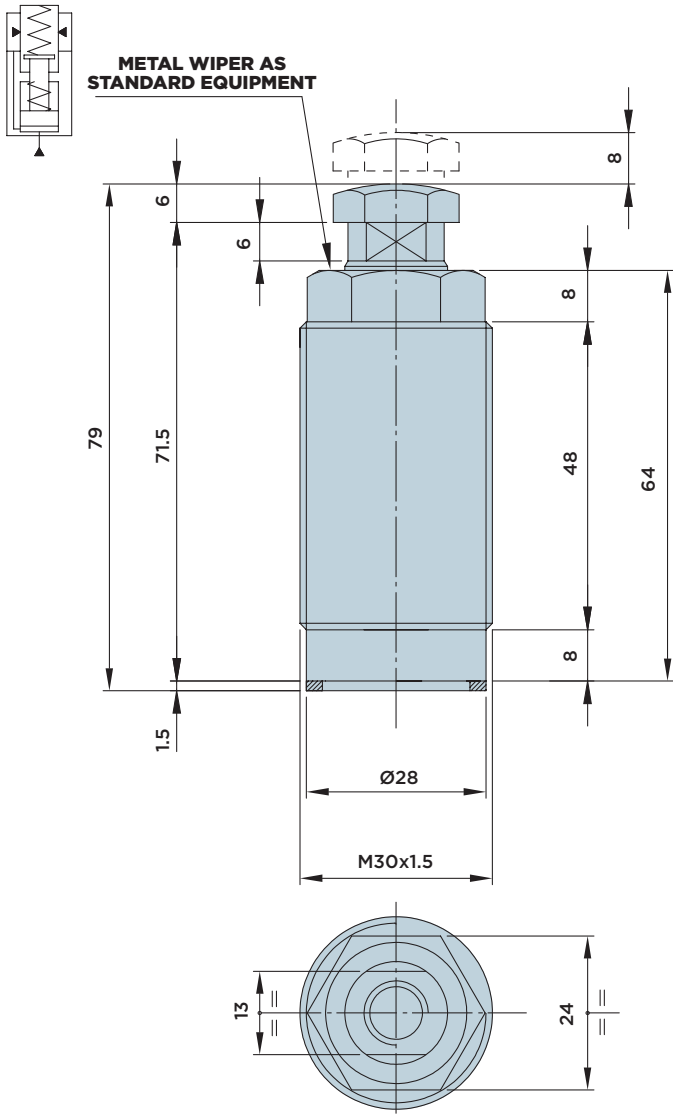

INSTALLATION DIMENSIONS

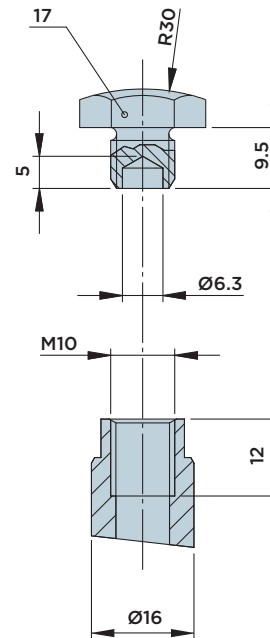
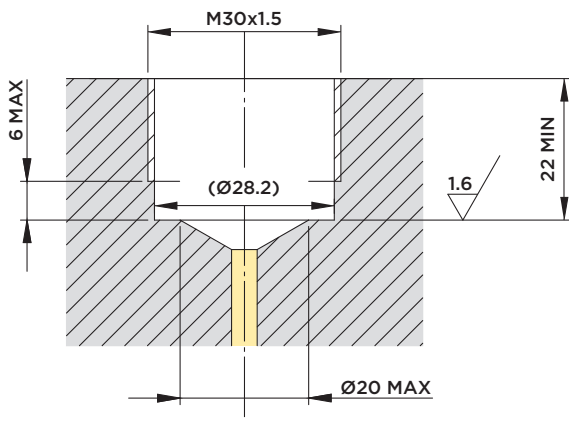

FORCE/PRESSURE/DEFLECTION DIAGRAM

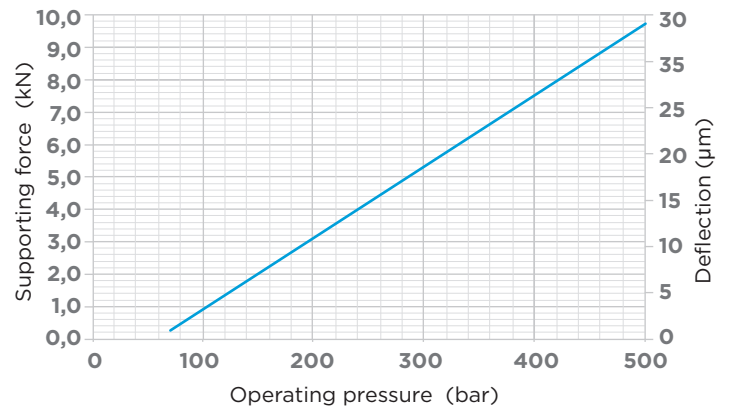

Note:

The maximum admissible flow rate amounts to 1.5 l/min.

Contact force:

- Standard 15÷35 N
- Upon request 10÷20 N (order no. IRFP16.0L)

Included in the scope of supply:

- Sealing ring Ø22xØ28x1.5

Material:

- Piston/rod: Case-hardened steel, ground.
- Body: Free machining steel, nitrocarburized.



HYDROBLOCK

IRFM 16.0

HYDRAULIC WORK SUPPORT WITH **THREADED BODY**

MAX. OPERATING PRESSURE = 500BAR

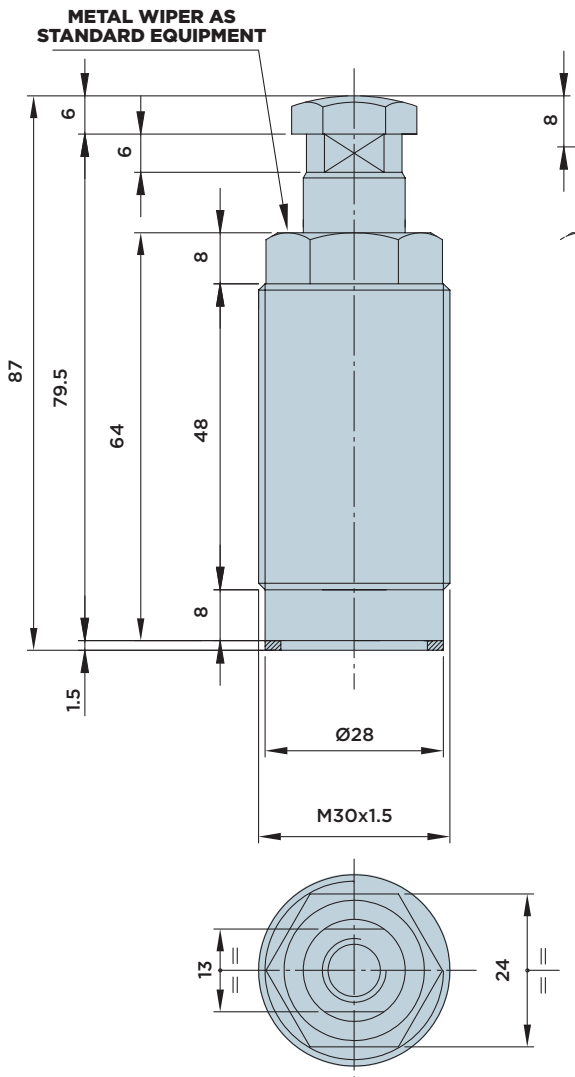

INSTALLATION DIMENSIONS

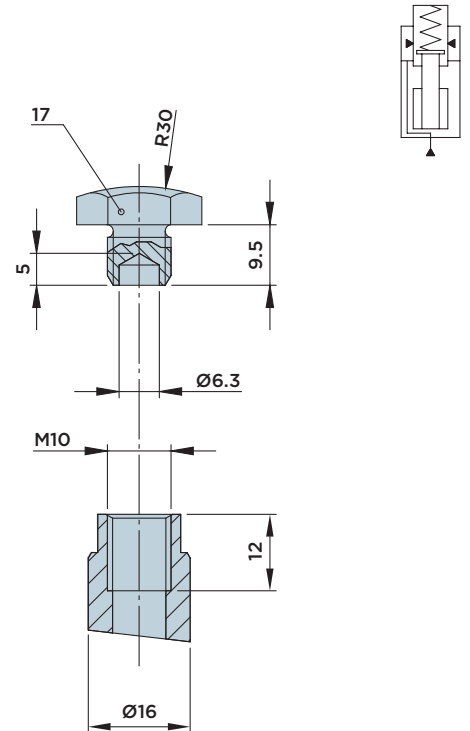
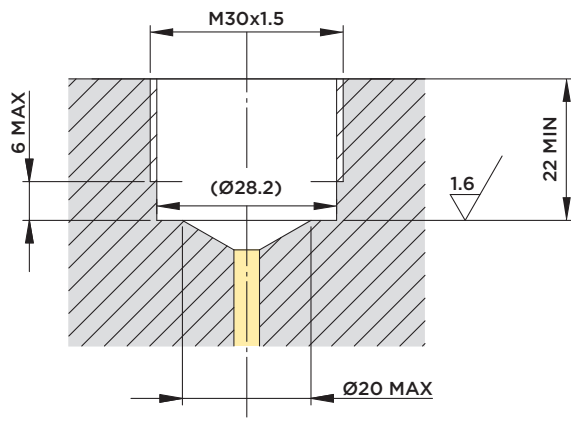

FORCE/PRESSURE/DEFLECTION DIAGRAM

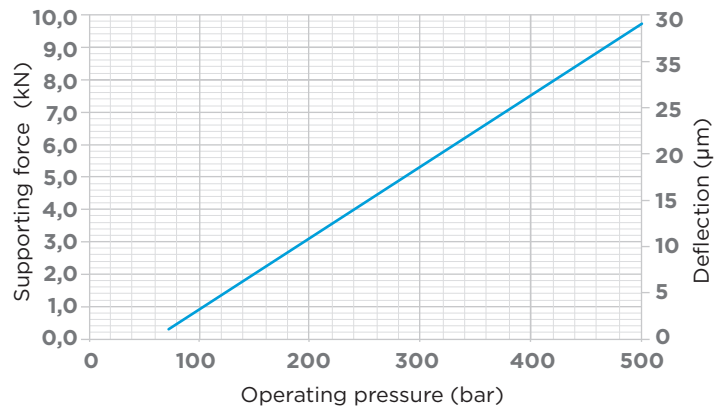

Note:

The maximum admissible flow rate amounts to 1.5 l/min.

Contact force:

- Standard 15÷35 N
- Upon request 10÷20 N (order no. IRFM16.0L)

Included in the scope of supply:

- Sealing ring Ø22xØ28x1.5

Material:

- Piston/rod: Case-hardened steel, ground.
- Body: Free machining steel, nitrocarburized.



HYDROBLOCK

IRFP 25.0

HYDRAULIC WORK SUPPORT WITH **THREADED BODY**

MAX. OPERATING PRESSURE = 500BAR

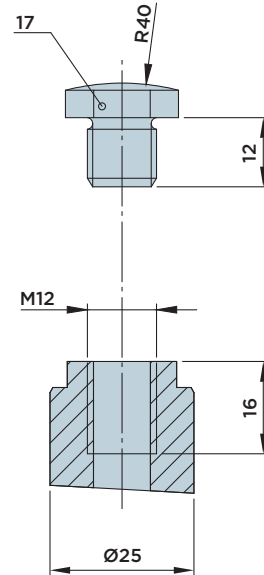
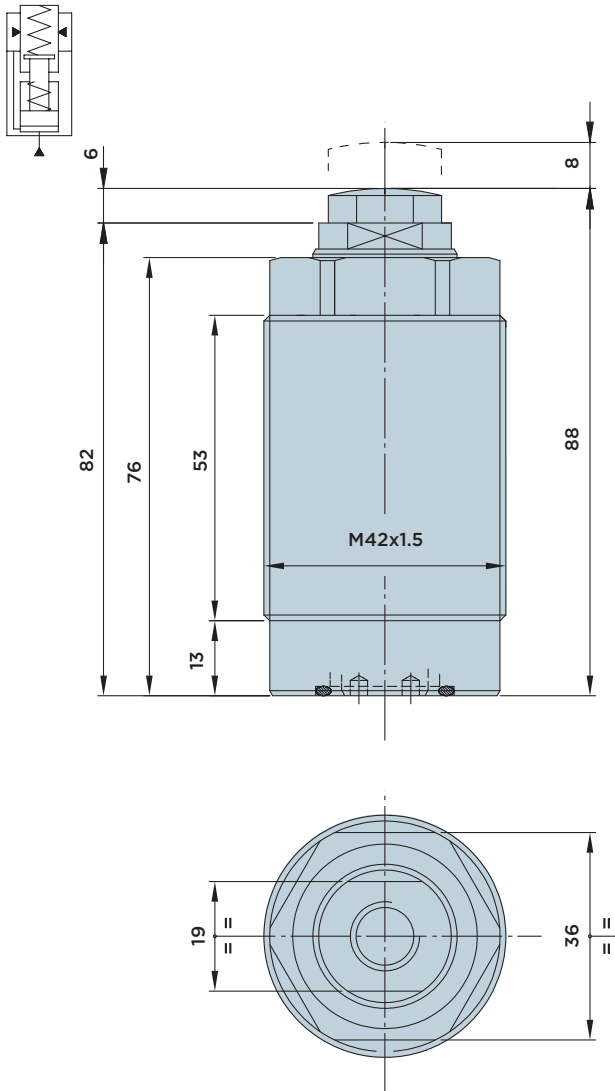

FORCE/PRESSURE/DEFLECTION DIAGRAM

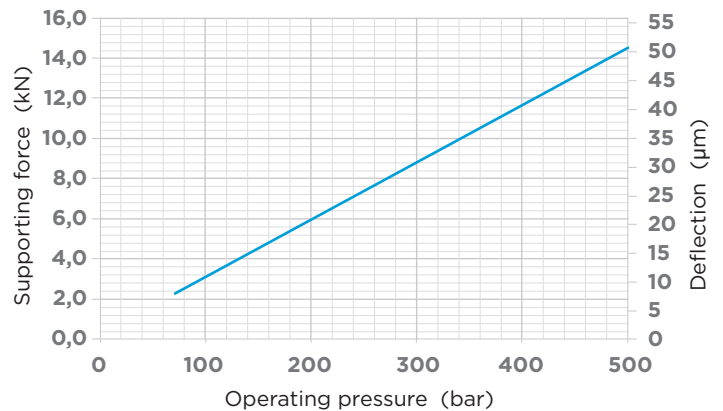

INSTALLATION DIMENSIONS

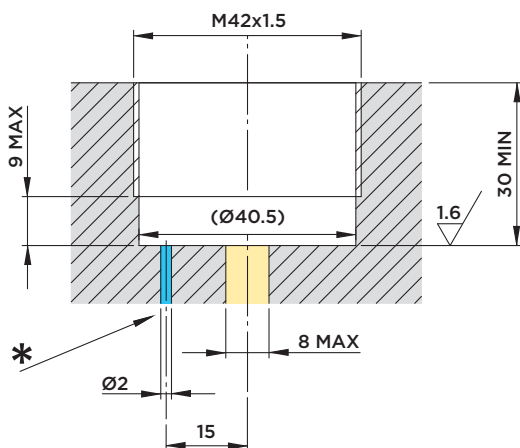

* Venting: We recommend installing a connection with a vent line leading into an area that is free from liquids and chips.

Note:

The maximum admissible flow rate amounts to 1.5 l/min.

Contact force:

- Standard 25÷35 N
- Upon request 10÷20 N (order no. IRFP25.0L)

Included in the scope of supply:

- O-Ring Ø18x3

Material:

- Piston/rod: Case-hardened steel, ground.
- Body: Free machining steel, nitrocarburized.



HYDROBLOCK

IRFM 25.0

HYDRAULIC WORK SUPPORT WITH **THREADED BODY**

MAX. OPERATING PRESSURE = 500BAR

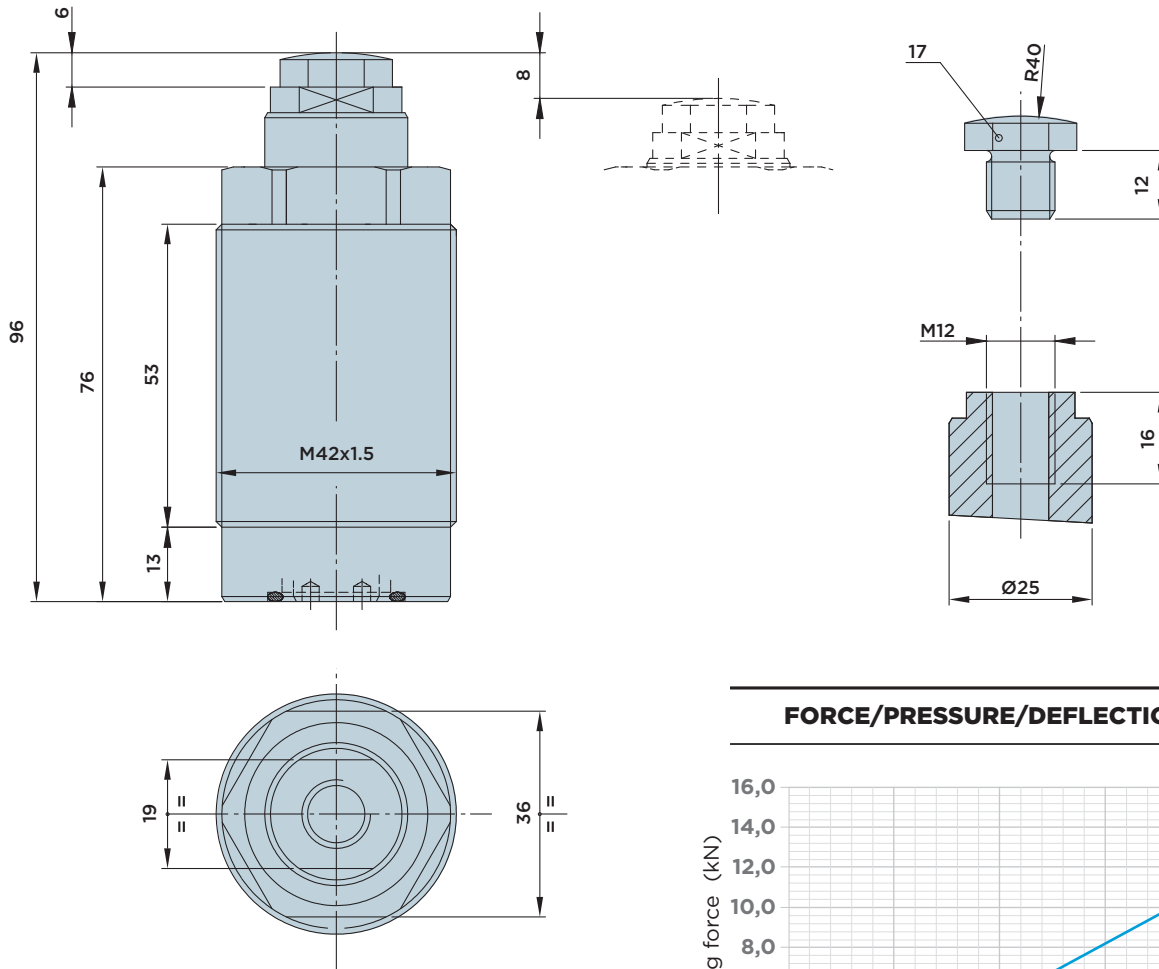

INSTALLATION DIMENSIONS

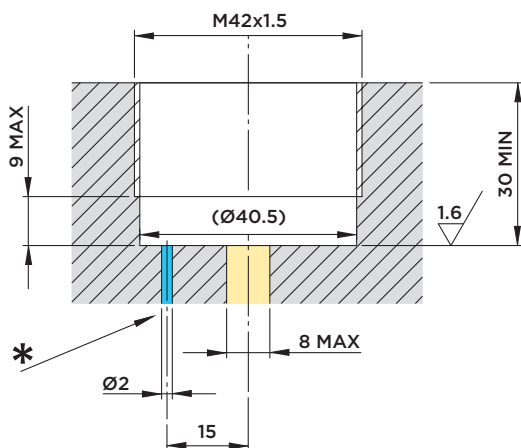

* Venting: We recommend installing a connection with a vent line leading into an area that is free from liquids and chips.

FORCE/PRESSURE/DEFLECTION DIAGRAM

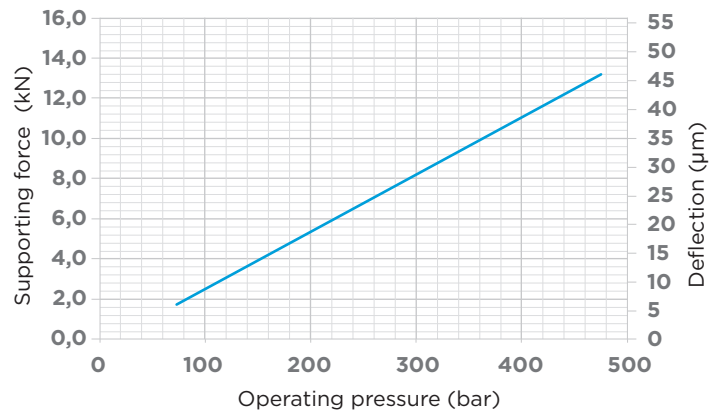

Note:

The maximum admissible flow rate amounts to 1.5 l/min.

Contact force:

- Standard 25÷35 N
- Upon request 10÷20 N (order no. IRFM25.0L)

Included in the scope of supply:

- O-Ring Ø9.92x2.62

Material:

- Piston/rod: Case-hardened steel, ground.
- Body: Free machining steel, nitrocarburized.

IRFP 25.1

HYDRAULIC WORK SUPPORT WITH **THREADED BODY**

MAX. OPERATING PRESSURE = 500BAR

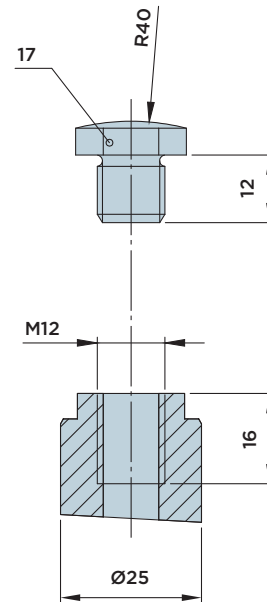
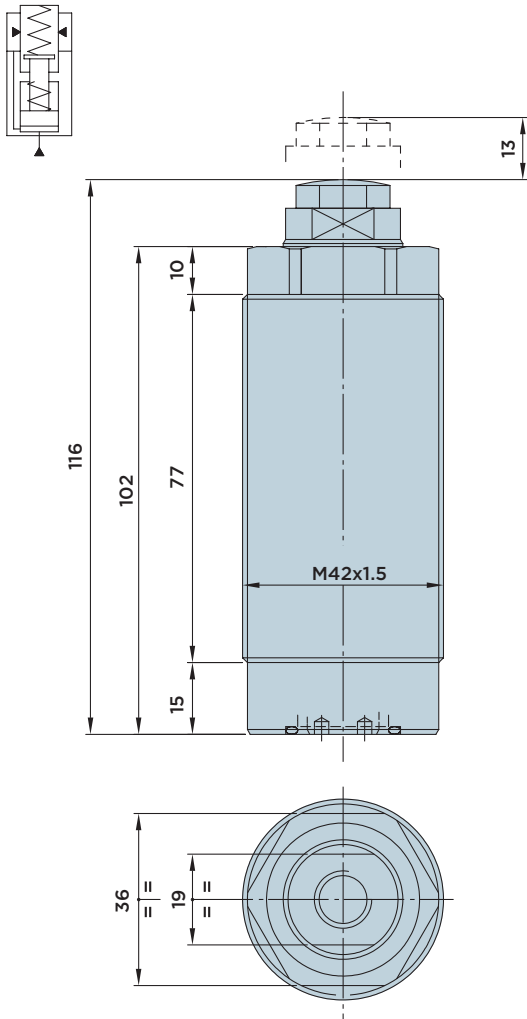

INSTALLATION DIMENSIONS

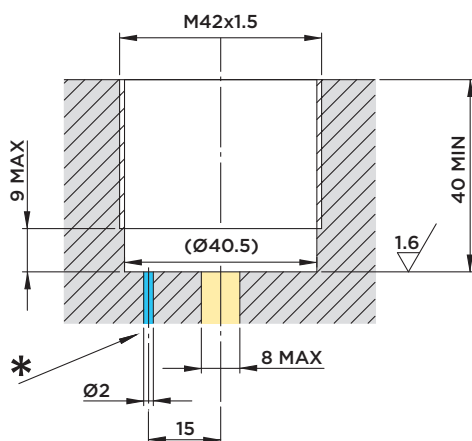

* Venting: We recommend installing a connection with a vent line leading into an area that is free from liquids and chips.

FORCE/PRESSURE/DEFLECTION DIAGRAM

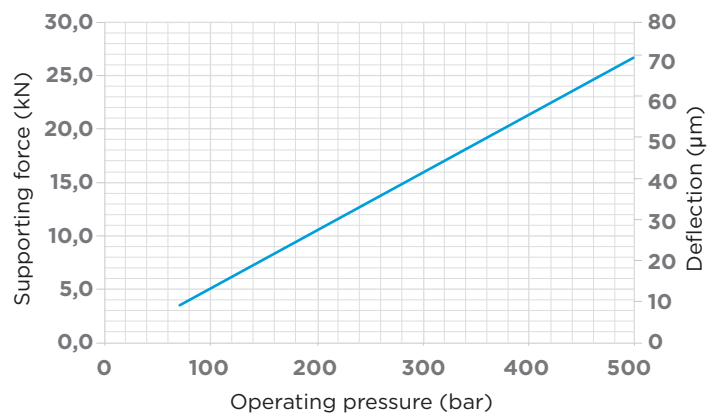

Note:

The maximum admissible flow rate amounts to 1.5 l/min.

Contact force:

- Standard 30÷50 N

Included in the scope of supply:

- O-Ring Ø18x3 mm

Material:

- Piston/rod: Case-hardened steel, ground.
- Body: Free machining steel, nitrocarburized.



HYDROBLOCK

IRFM 25.1

HYDRAULIC WORK SUPPORT WITH **THREADED BODY**

MAX. OPERATING PRESSURE = 500BAR

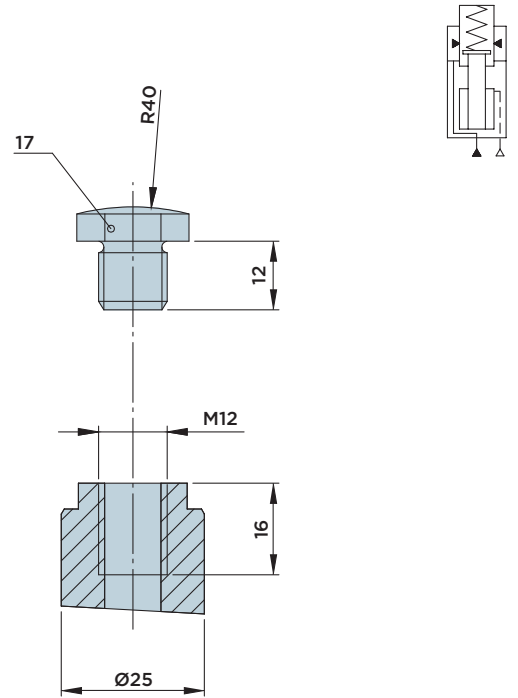
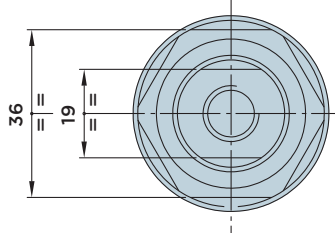
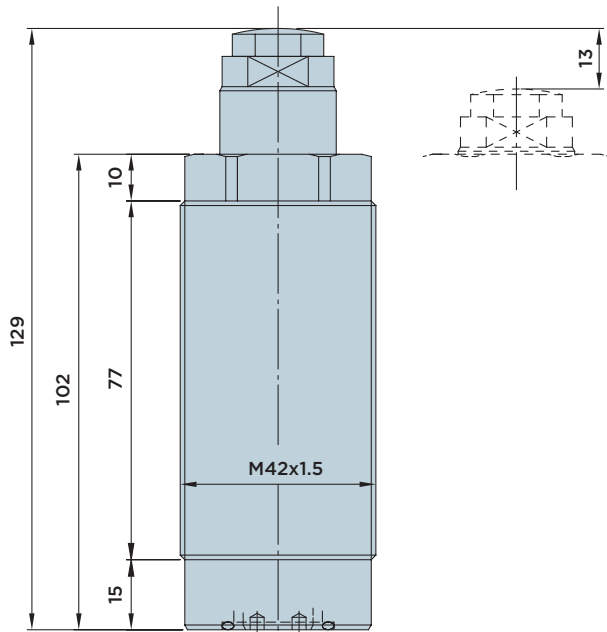

INSTALLATION DIMENSIONS

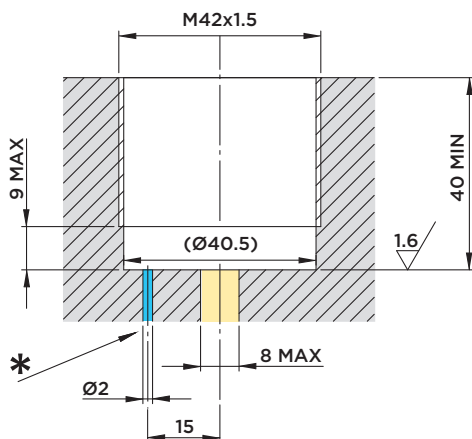

* Venting: We recommend installing a connection with a vent line leading into an area that is free from liquids and chips.

FORCE/PRESSURE/DEFLECTION DIAGRAM

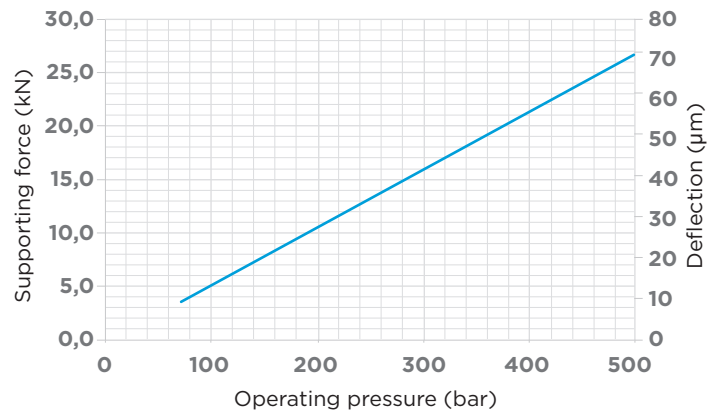

Note:

The maximum admissible flow rate amounts to 1.5 l/min.

Contact force:

- Standard 30÷50 N

Included in the scope of supply:

- O-Ring Ø9.92x2.62

Material:

- Piston/rod: Case-hardened steel, ground.
- Body: Free machining steel, nitrocarburized.



HYDROBLOCK

IRFP 32.0

HYDRAULIC WORK SUPPORT WITH **THREADED BODY**

MAX. OPERATING PRESSURE = 500BAR

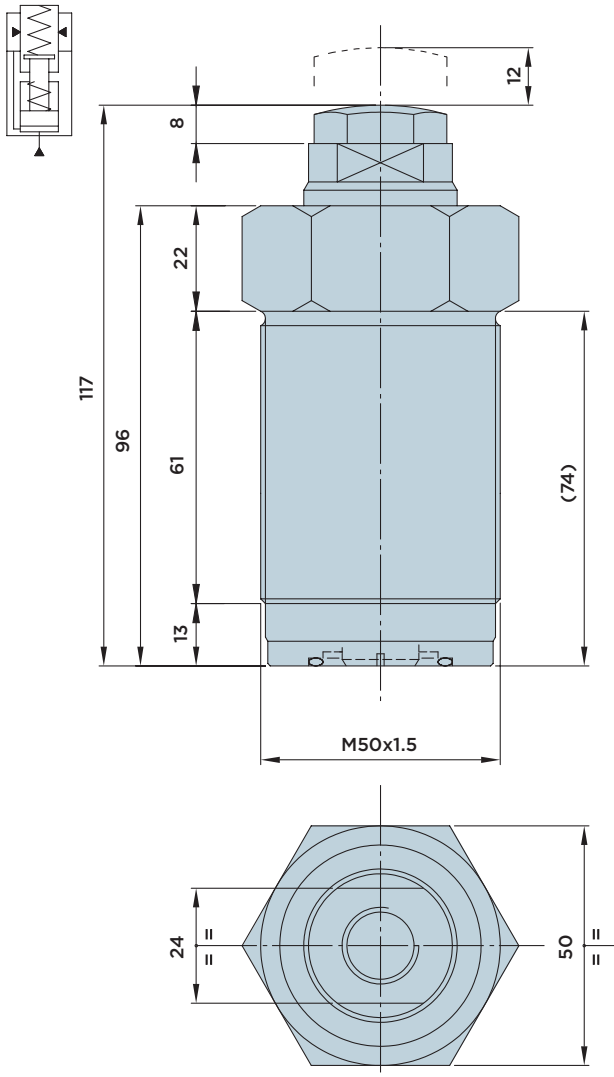

INSTALLATION DIMENSIONS

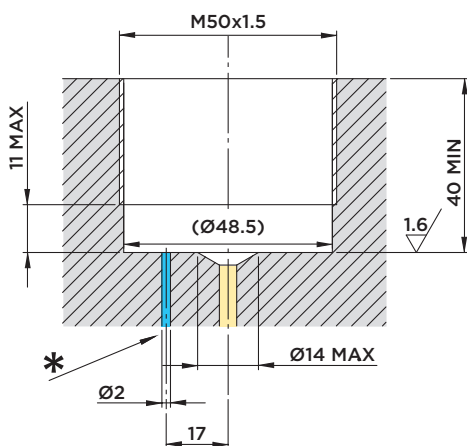

* Venting: We recommend installing a connection with a vent line leading into an area that is free from liquids and chips.

FORCE/PRESSURE/DEFLECTION DIAGRAM

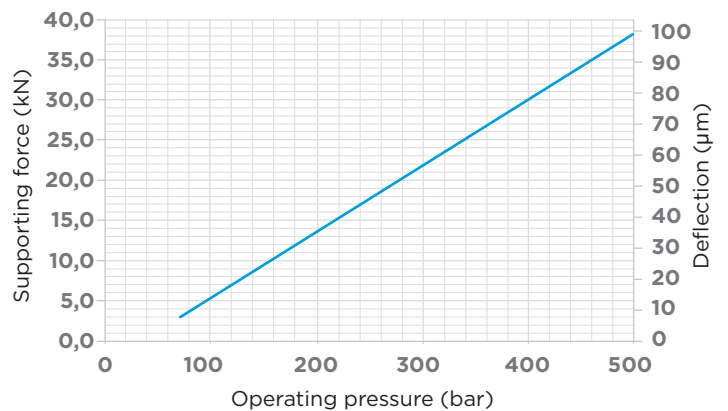

Note:

The maximum admissible flow rate amounts to 1.5 l/min.

Contact force:

- Standard 35÷60 N

Included in the scope of supply:

- O-Ring Ø25.07x2.62

Material:

- Piston/rod: Case-hardened steel, ground.
- Body: Free machining steel, nitrocarburized.



HYDROBLOCK

IRFM 32.0

HYDRAULIC WORK SUPPORT WITH **THREADED BODY**

MAX. OPERATING PRESSURE = 500BAR

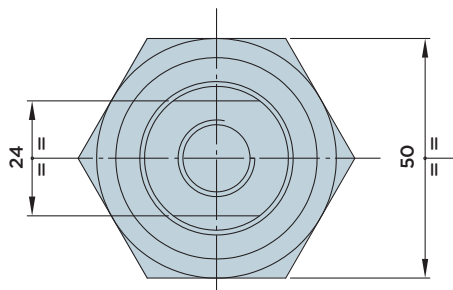
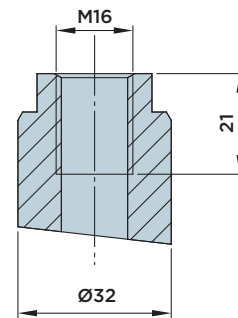
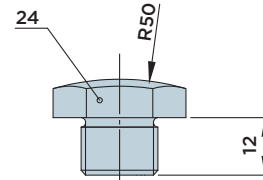
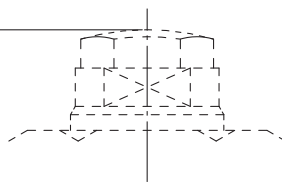
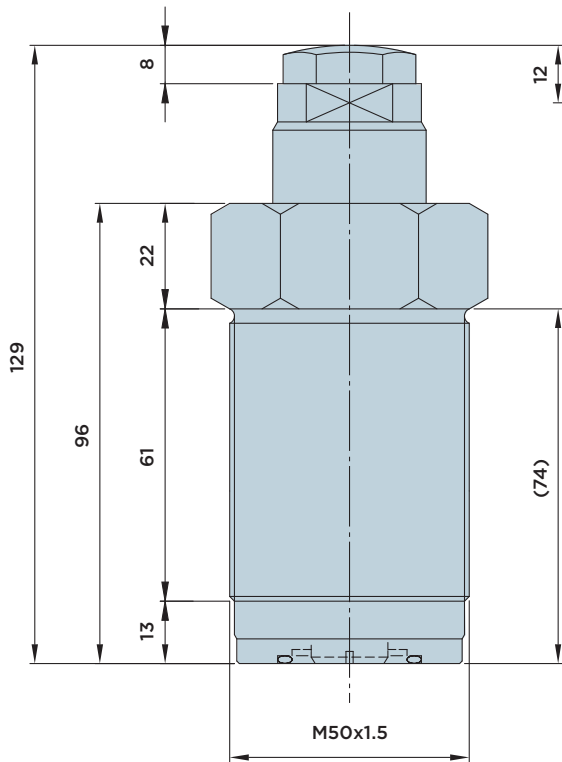

INSTALLATION DIMENSIONS

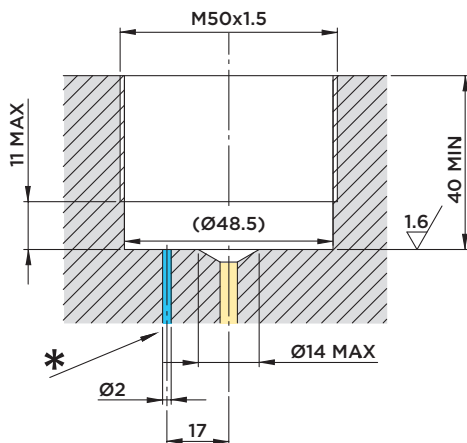

* Venting: We recommend installing a connection with a vent line leading into an area that is free from liquids and chips.

FORCE/PRESSURE/DEFLECTION DIAGRAM

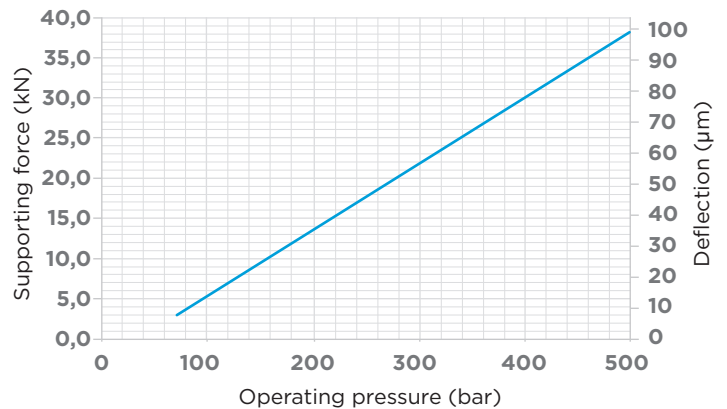

Note:

The maximum admissible flow rate amounts to 1.5 l/min.

Contact force:

- Standard 35-60 N

Included in the scope of supply:

- O-Ring Ø15.08x2.62

Material:

- Piston/rod: Case-hardened steel, ground.
- Body: Free machining steel, nitrocarburized.



HYDROBLOCK

IRCM 32.0

HYDRAULIC WORK SUPPORT WITH **CARTRIDGE BODY**

MAX. OPERATING PRESSURE = 500BAR

A : Clamping

B : Venting

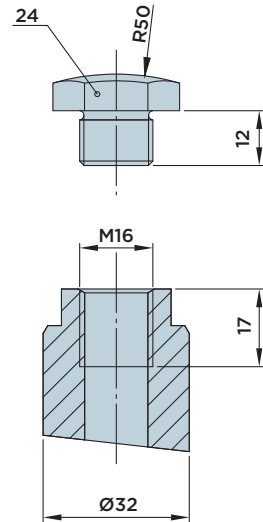
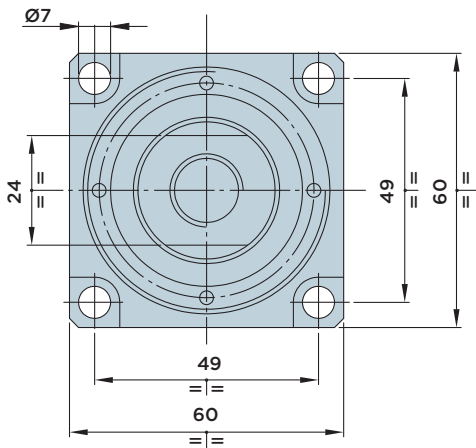
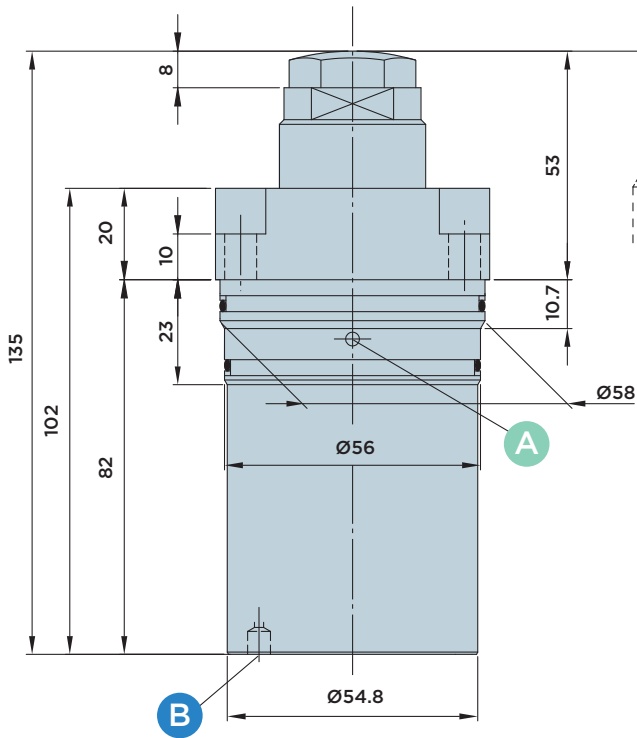

FORCE/PRESSURE/DEFLECTION DIAGRAM

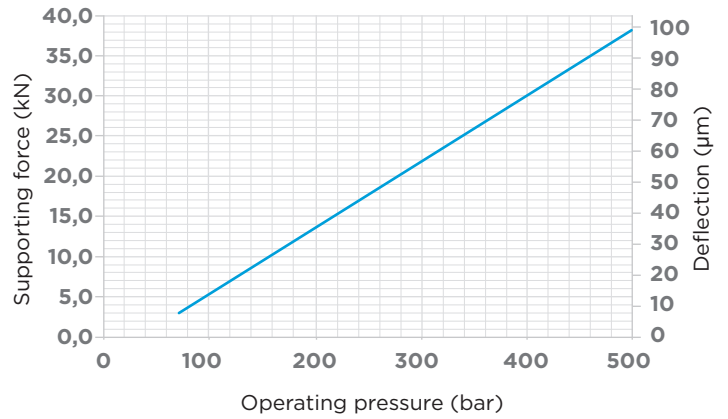

Included in the scope of supply:

- Mounting screws M6x20 DIN912/12.9 grade

Material:

- Piston/rod: Case-hardened steel, ground.
- Body: Free machining steel, nitrocarburized.

NOTE:

The maximum admissible flow rate amounts to 1.5 l/min.

Contact force:

- Standard 35÷60 N



IRFLP 32.0

HYDRAULIC WORK SUPPORT WITH **UPPER FLANGE**

MAX. OPERATING PRESSURE = 500BAR

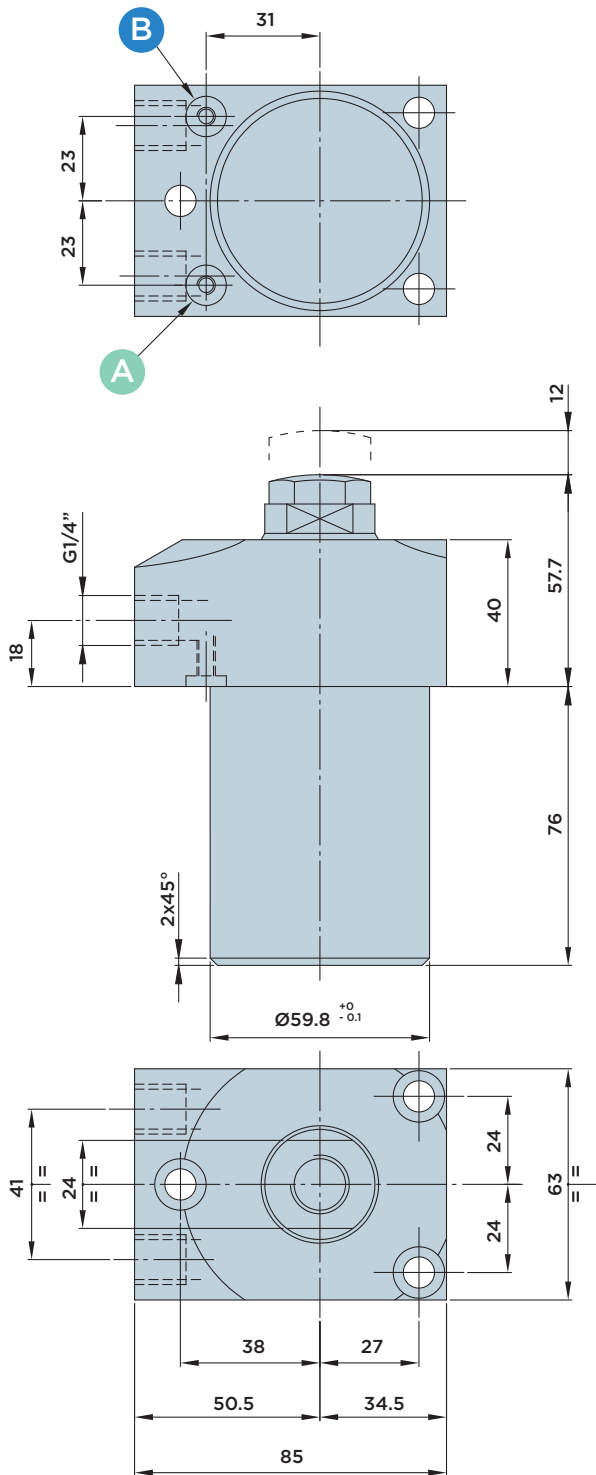
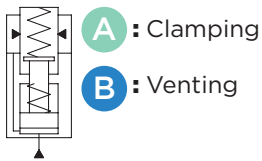

INSTALLATION DIMENSIONS

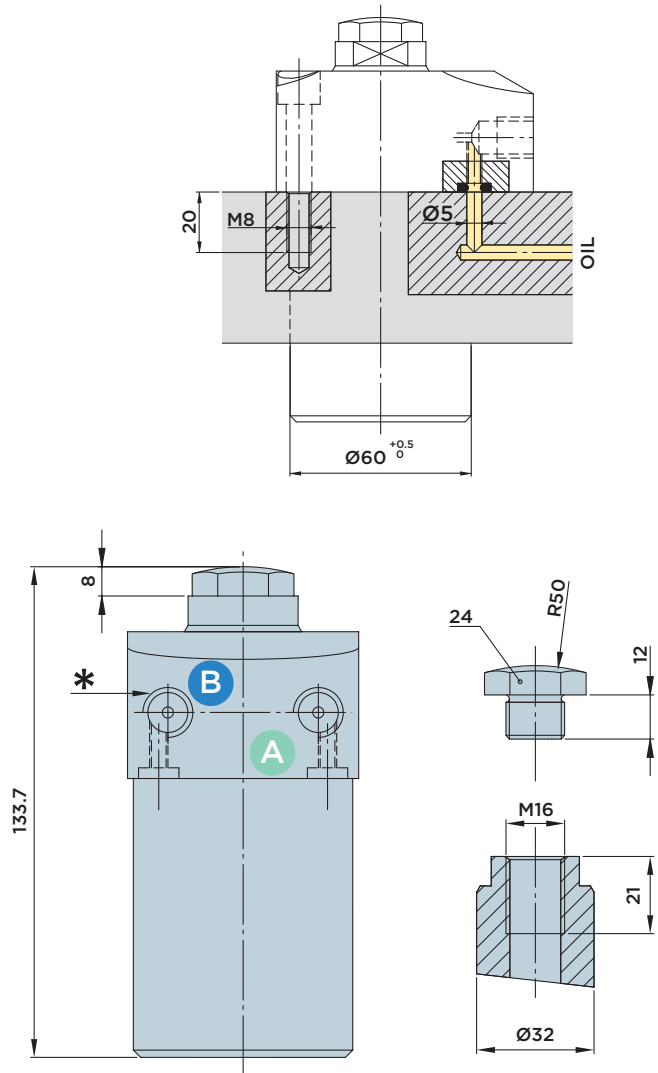

* When the external vent port is used, a vent pipe must be connected that leads into an area that is free from liquids and chips.

Note:

The maximum admissible flow rate amounts to 1.5 l/min.

Contact force:

- Standard 35÷60 N

Included in the scope of supply:

- Mounting screws M8x45 DIN912/12.9 grade
- O-rings $\varnothing 4.34 \times 3.53$

Material:

- Piston/rod: Case-hardened steel, ground.
- Body: Free machining steel, nitrocarburized.



HYDROBLOCK

IRFLM 32.0

HYDRAULIC WORK SUPPORT WITH **UPPER FLANGE**

MAX. OPERATING PRESSURE = 500BAR

A : Clamping

B : Venting

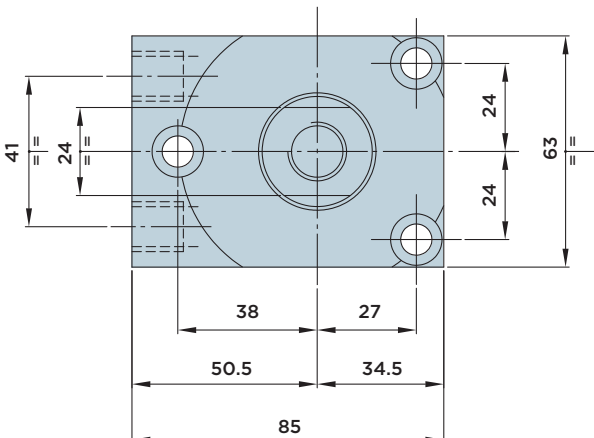
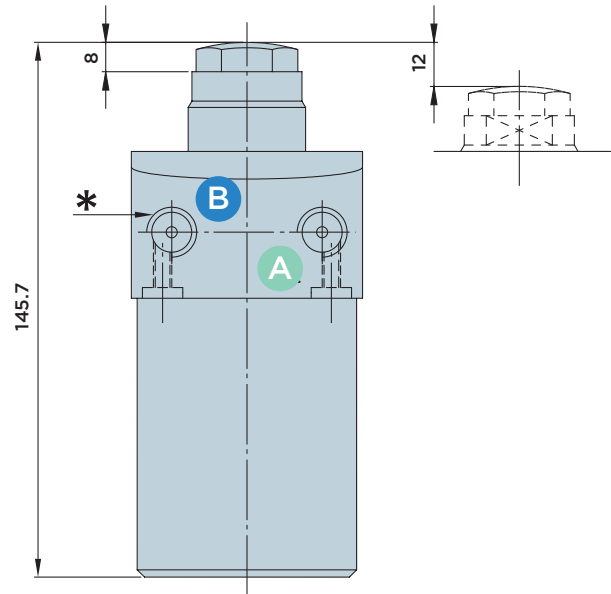
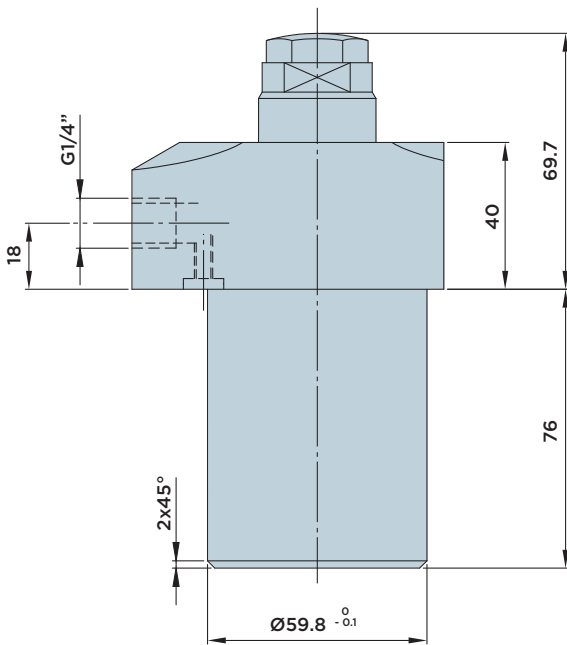
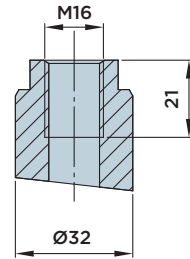
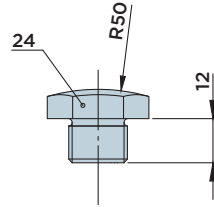
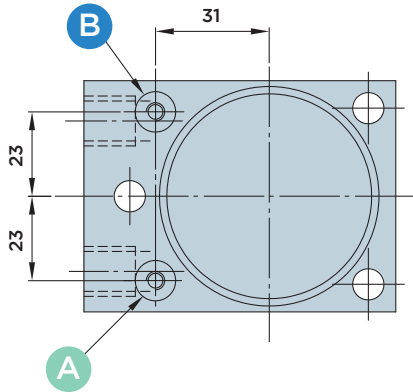
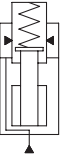

FORCE/PRESSURE/DEFLECTION DIAGRAM

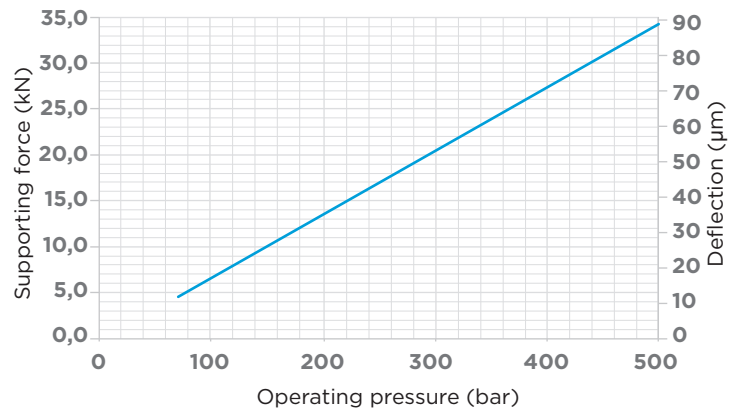

IRPLM 40.0

HYDRAULIC WORK SUPPORT WITH **LOWER FLANGE**

MAX. OPERATING PRESSURE = 500BAR

A : Clamping

B : Venting

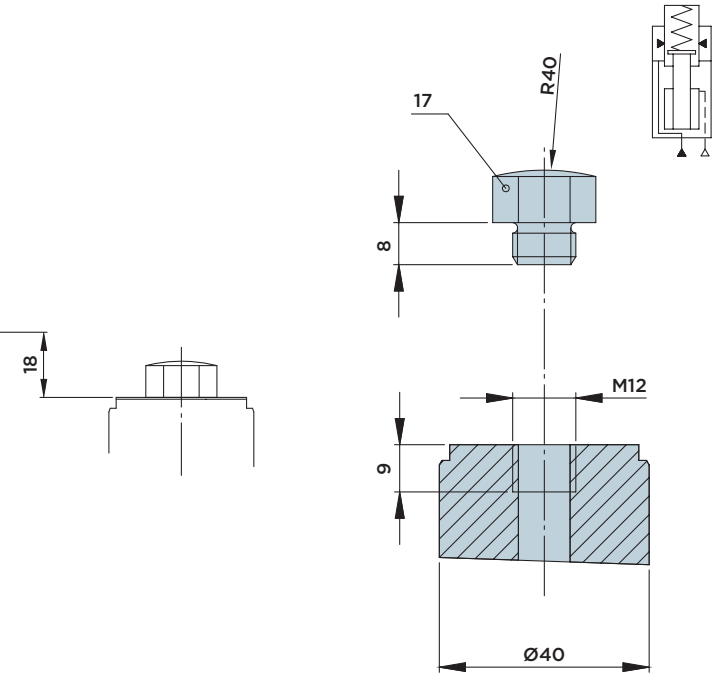
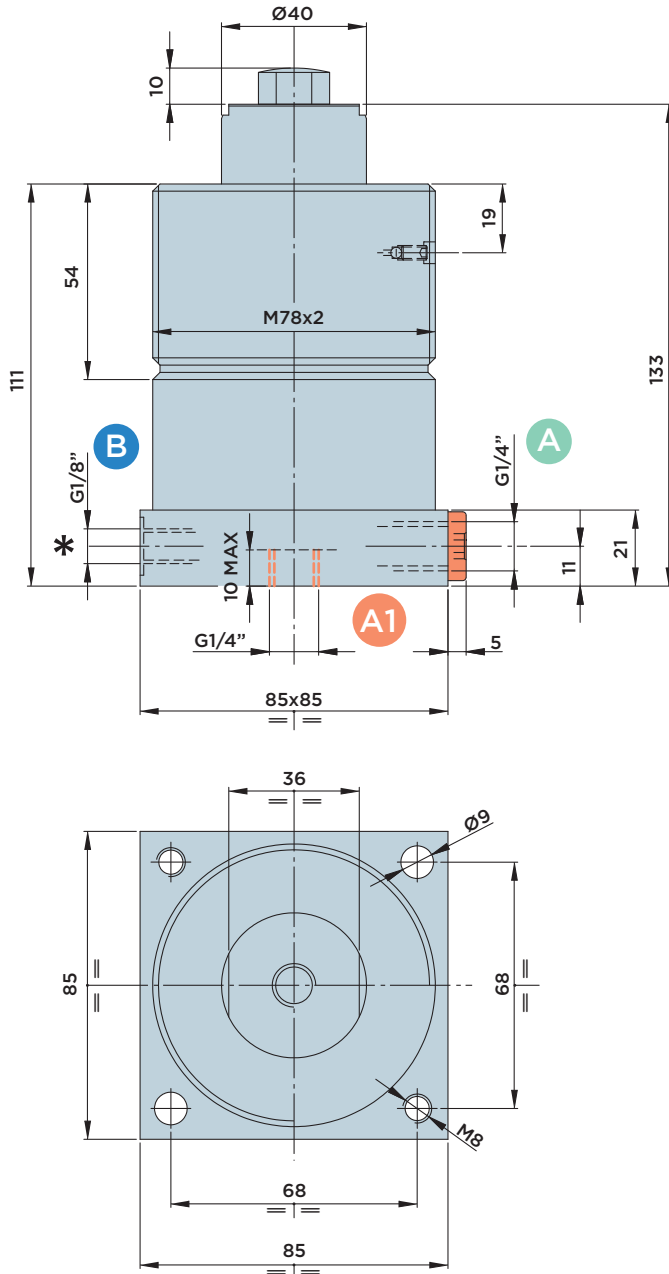

FORCE/PRESSURE/DEFLECTION DIAGRAM

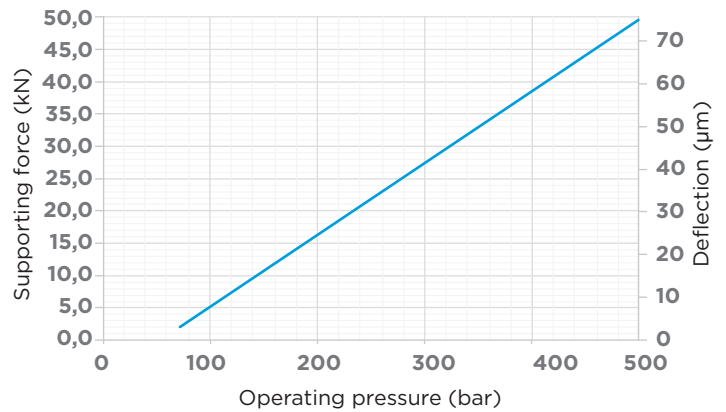

* The B port is delivered with a sintered integrated filter in the standard version.

Note:

The maximum admissible flow rate amounts to 1.5 l/min.

Contact force:

- Standard 60±90 N

Included in the scope of supply:

- Mounting screws M8x35 DIN912/12.9 grade

Material:

- Piston/rod: Case-hardened steel, ground.
- Body: Free machining steel, nitrocarburized.

A1 A version with A1 port at the bottom of the flange is available upon request (order no. IRFL40.1). In this case, the A port is closed by means of a plug.



HYDROBLOCK

IR PRESSURIZED WORK SUPPORTS

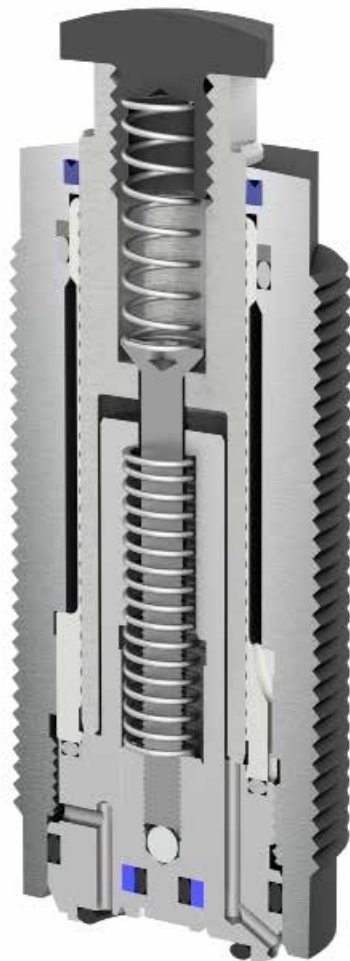

The new pressurized work support has been developed for applications in which commercial standard work supports reach their limits. This new model is available with hydraulic approach and in normally extended version, with the function being identical with standard work supports. The additional pneumatic line allows the correctly clamped work support to be pressurized and thus protects the internal mechanics against environmental influences. When the cylinder is clamped and pressurized, it is protected against cooling lubricants directed onto the rod. This model can also be flush-mounted and remains fully operative even when immersed in chips or cooling lubricants. To ensure correct use, the work support must be pressurized after clamping. If the cylinder is supplied with compressed air

before, extremely sensitive workpieces may be deformed as the rod would act as a pneumatic piston. Only with a compressed air supply of very low pressure ranging between 0.1 and 0.2 bar, will the workpiece deformation be so small that it can be neglected in most cases. After "normal" clamping, however, the work support can be pressurized with substantially higher pressure values that correspond to the usual compressed air mains.

ATTENTION: Upon completion of the working cycle, the pneumatic supply must be interrupted before the hydraulic work support is unclamped.

UPON REQUEST THE OTHER HYDRAULIC WORK SUPPORT SIZES ARE ALSO AVAILABLE IN A PRESSURIZED VERSION.



HYDROBLOCK

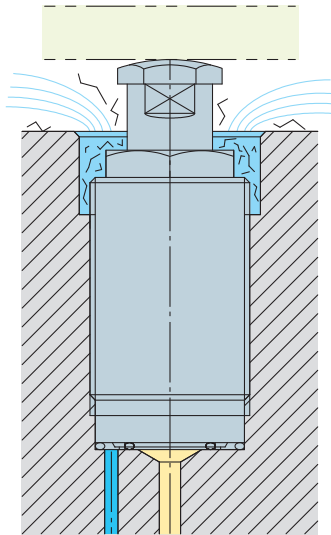

For certain applications where the correct function of hydraulic work supports cannot be guaranteed, the new pressurized IRF offers a highly efficient solution for classical application problems encountered with conventional work supports. This new model can be immersed in cooling lubricant or directly exposed to the cooling lubricant flow to ensure efficient chip removal, without affecting the proper function over a long period of operation.

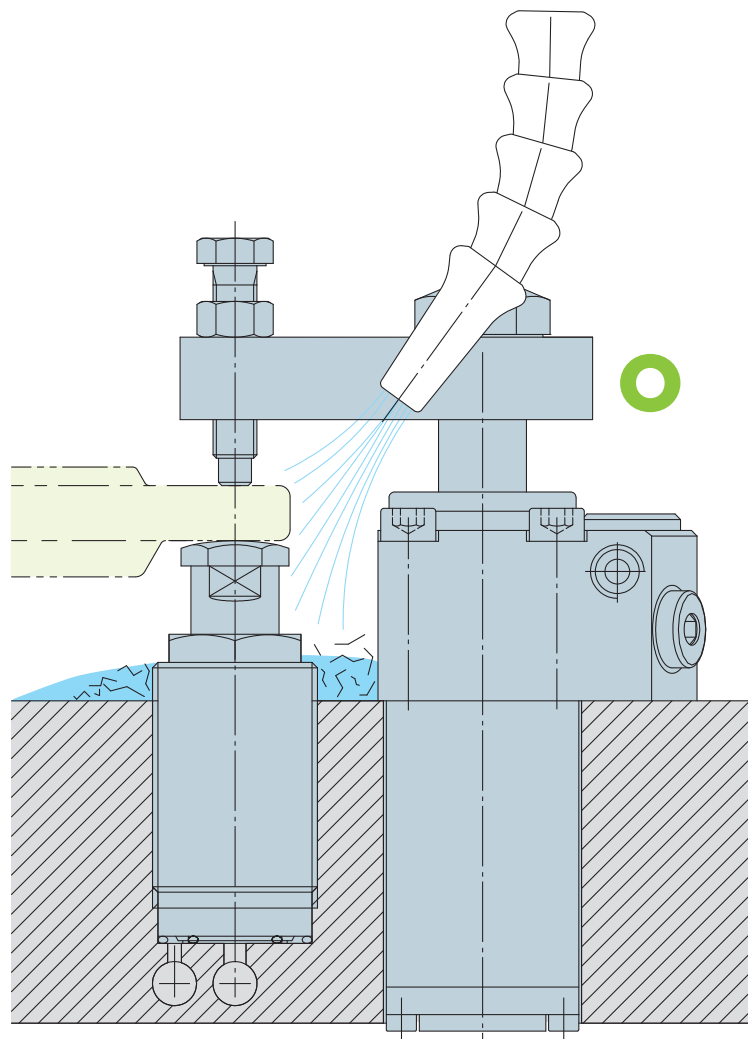

IRFP 16.10A

PRESSURIZED WORK SUPPORTS WITH THREADED BODY

MAX. OPERATING PRESSURE = 500BAR

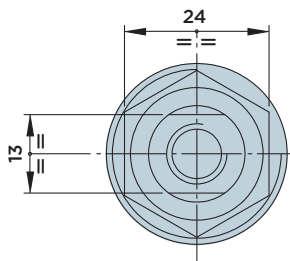
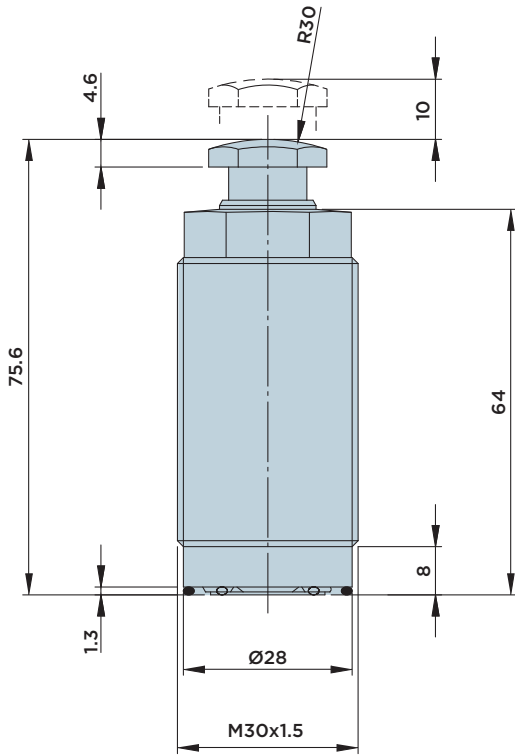

INSTALLATION DIMENSIONS

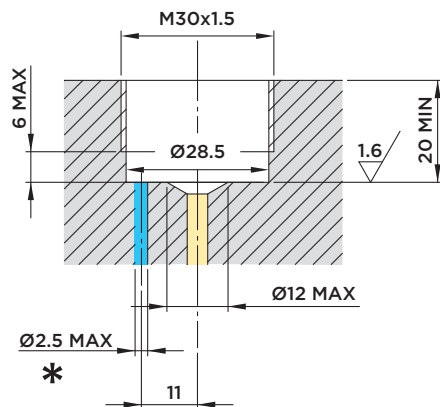

* Pneumatic supply: see page 281.

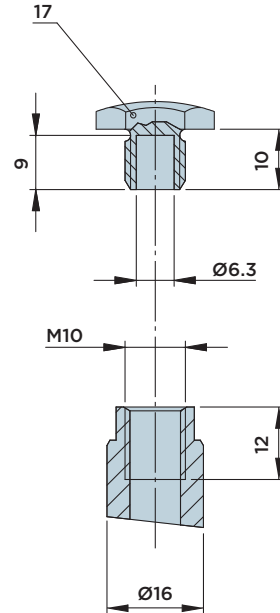

FORCE/PRESSURE/DEFLECTION DIAGRAM

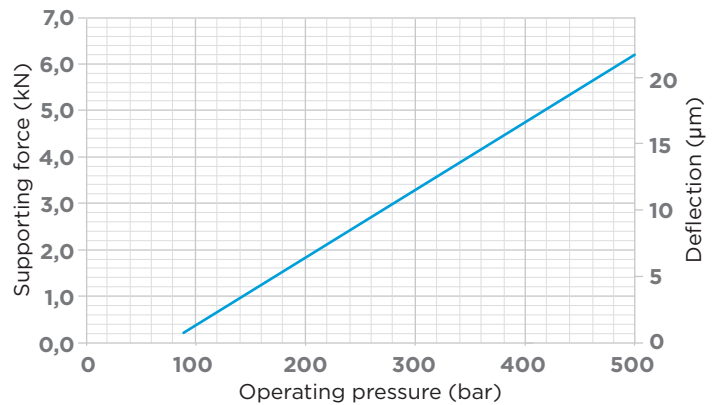

Note:

The maximum admissible flow rate amounts to 1.5 l/min.

Contact force:

- Standard 15÷30 N
- Upon request 8÷20 N (order no. IRFM16.10AL)

Included in the scope of supply:

- O-ring Ø14x1.78
- O-ring Ø23.52x1.78

Material:

- Piston/rod: Case-hardened steel, ground.
- Body: Free machining steel, nitrocarburized.



HYDROBLOCK

IRFM 16.10A

PRESSURIZED WORK SUPPORTS WITH THREADED BODY

MAX. OPERATING PRESSURE = 500BAR

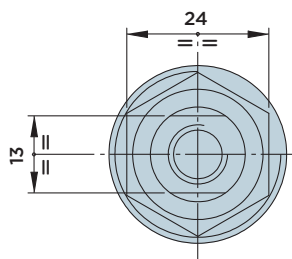
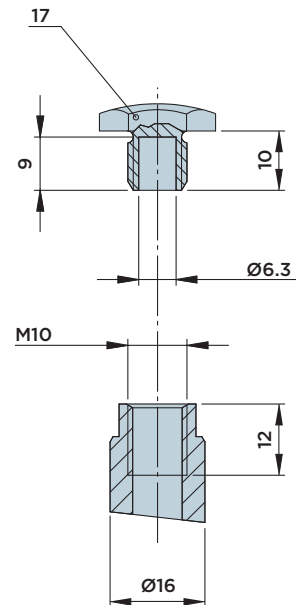
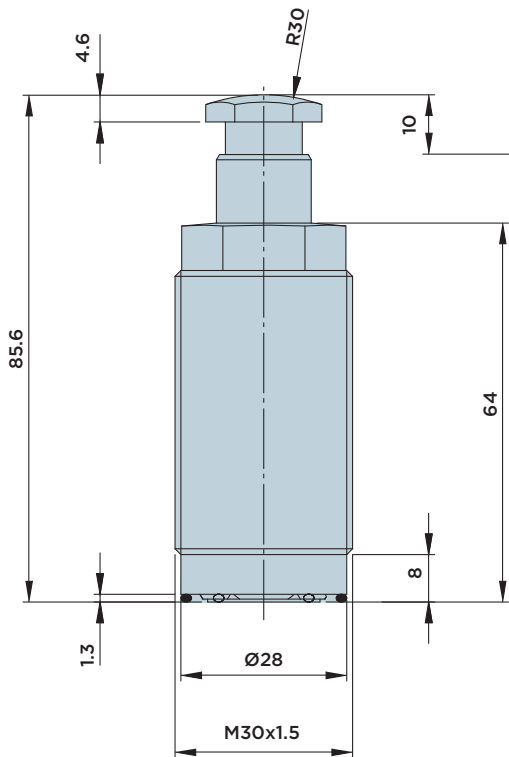

INSTALLATION DIMENSIONS

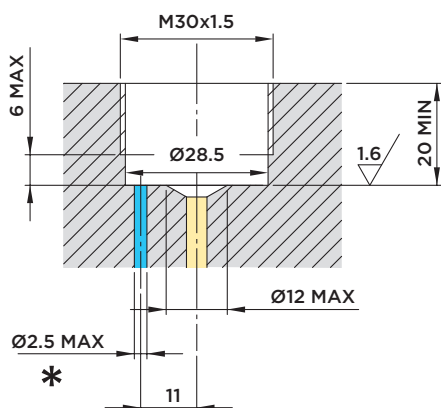

* Pneumatic supply: see page 281.

FORCE/PRESSURE/DEFLECTION DIAGRAM

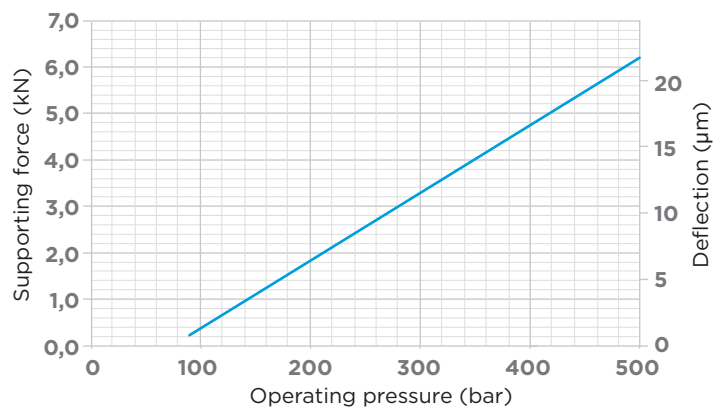

Note:

The maximum admissible flow rate amounts to 1.5 l/min.

Contact force:

- Standard 15÷30 N
- Upon request 8÷20 N (order no. IRFM16.10AL)

Included in the scope of supply:

- O-ring Ø14x1.78
- O-ring Ø23.52x1.78

Material:

- Piston/rod: Case-hardened steel, ground.
- Body: Free machining steel, nitrocarburized.



HYDROBLOCK

IR

DOUBLE-ACTING HYDRAULIC WORK SUPPORTS



HYDROBLOCK

IR

DOUBLE-ACTING HYDRAULIC WORK SUPPORTS

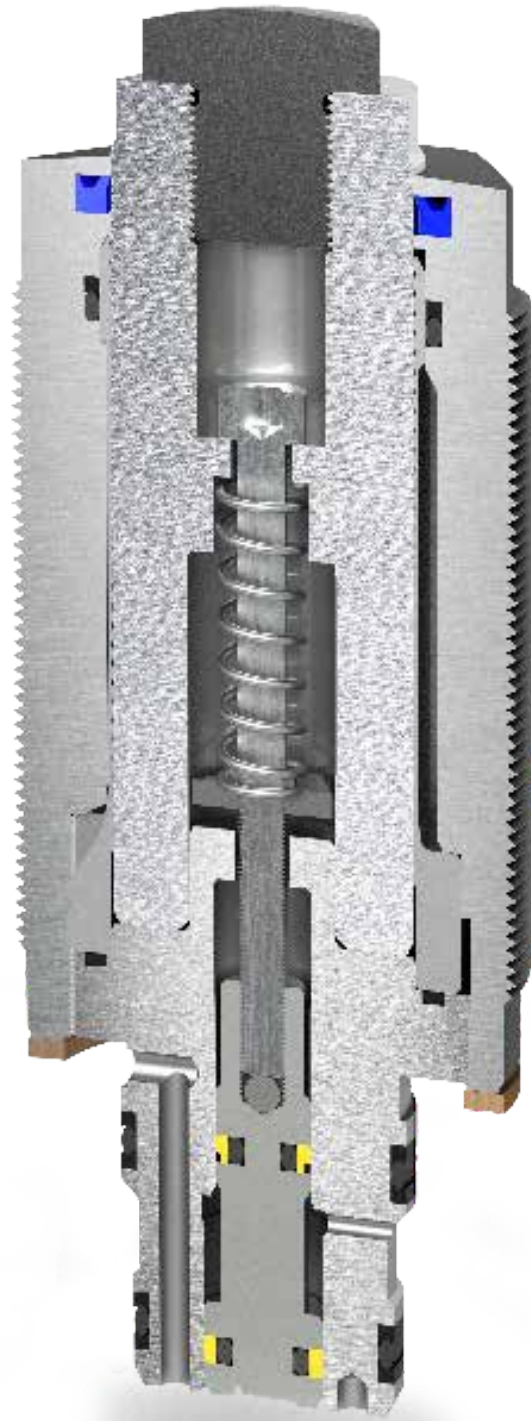

HYDROBLOCK

APPLICATION EXAMPLES

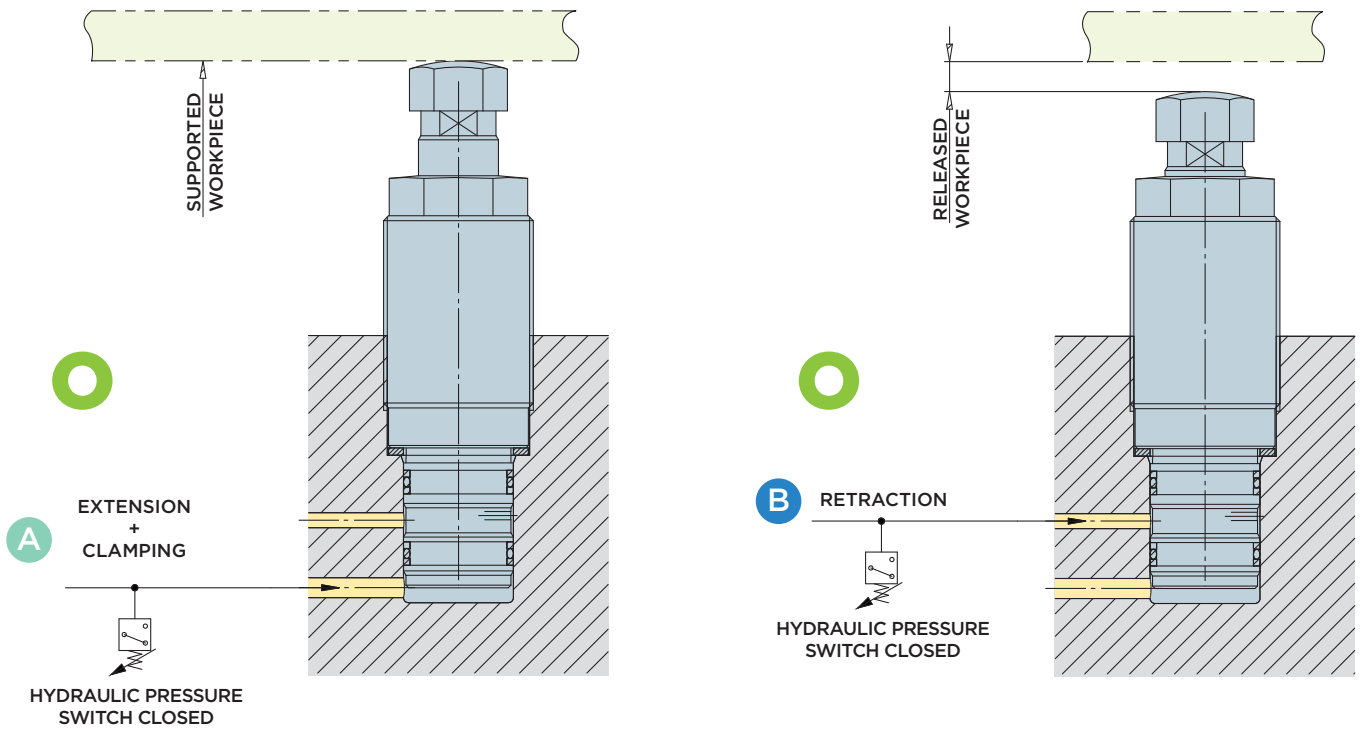

The IRFP double-acting hydraulic work supports have been developed to ensure safe and reliable return of the cylinder into rest position. With conventional single-acting work supports, only a return spring is used to move the rod back into the retracted rest position. In the event of back-pressures in the supply line, returning into rest position **CANNOT** be guaranteed with single-acting work supports as even when the cylinder is unclamped, the rod may remain still partially or even completely extended. Double-acting work supports are designed to exclude this risk. Their function is similar to that of the single-acting version, i.e. the approach to the machined workpiece and the clamping of the workpiece in the

correct position are ensured by the supply of the hydraulic clamping line A, while the counter line B remains unpressurized.

Once the machining cycle is completed, however, the supply of double-acting hydraulic work supports is simply inverted (line B is pressurized and line A remains unpressurized) to ensure complete and reliable retraction of the rod and to provide unhindered access to the workpiece loading/unloading position.

The enable signal of the hydraulic pressure switch on line B confirms that the retraction position is reached and guarantees perfect conditions for the subsequent loading/unloading operations.



IRFP 16SD

HYDRAULIC WORK SUPPORT WITH **UPPER FLANGE DOUBLE-ACTING**

MAX. OPERATING PRESSURE = 350BAR

A : Extension + Clamping

B : Retraction

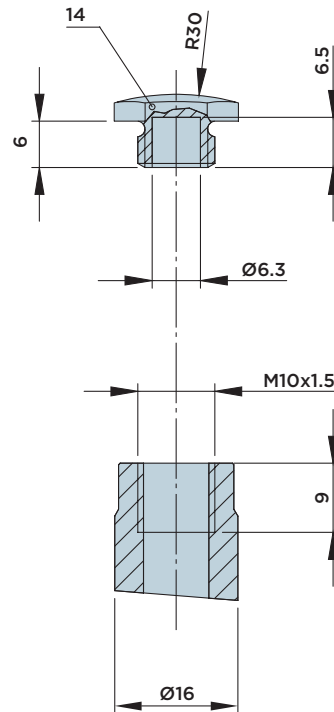
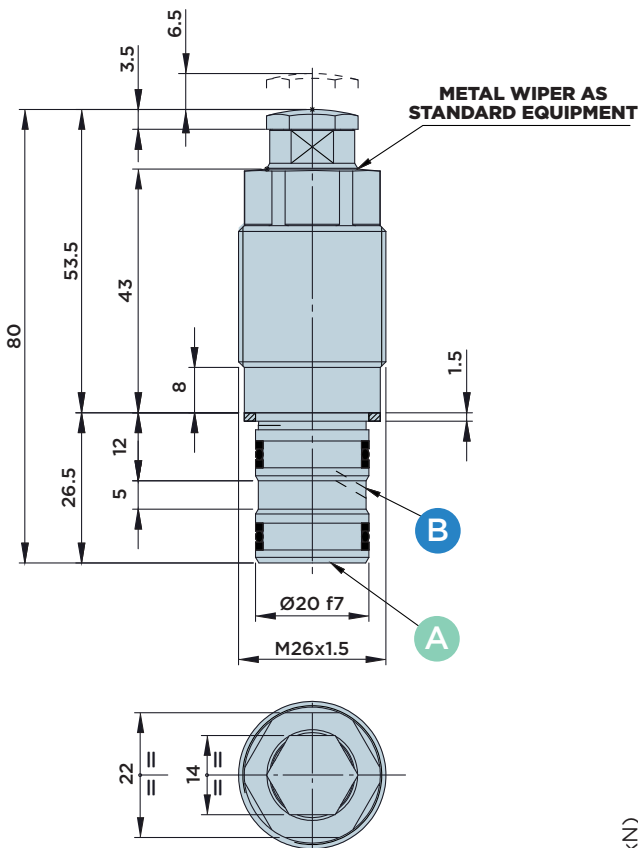

INSTALLATION DIMENSIONS

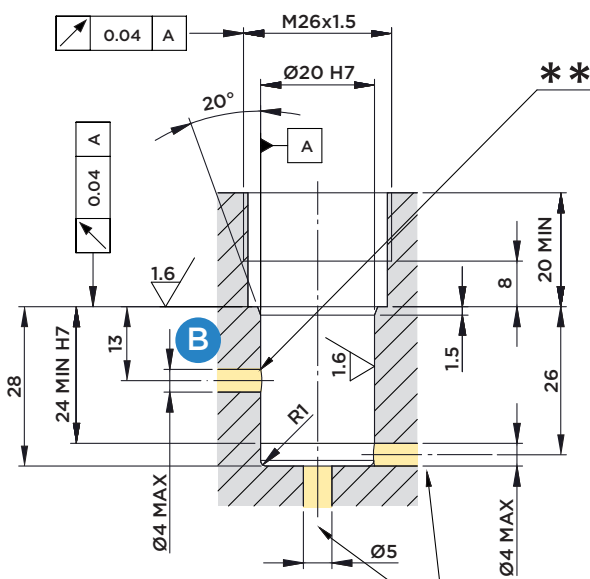

FORCE/PRESSURE/DEFLECTION DIAGRAM

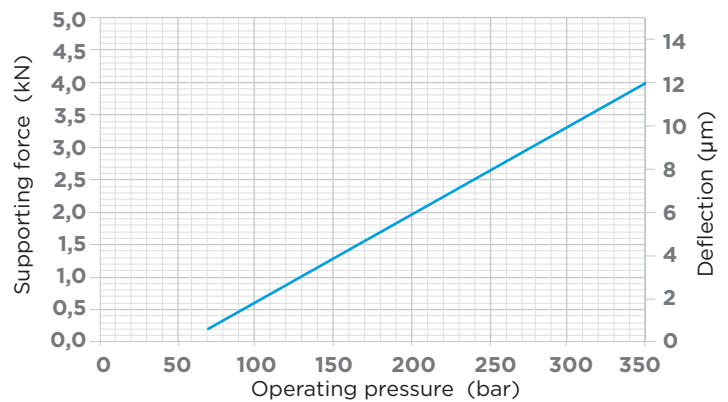

Note:

The maximum admissible flow rate amounts to 1.5 l/min.

Contact force:

- Standard 15÷35 N

Included in the scope of supply:

- Sealing ring Ø20.5xØ24x1.5

Material:

- Piston/rod: Case-hardened steel, ground.
- Body: Free machining steel, nitrocarburized.

** Debur and round off any edges



HYDROBLOCK

IRFP 16.8D

HYDRAULIC WORK SUPPORT WITH **UPPER FLANGE DOUBLE-ACTING**

MAX. OPERATING PRESSURE = 500BAR

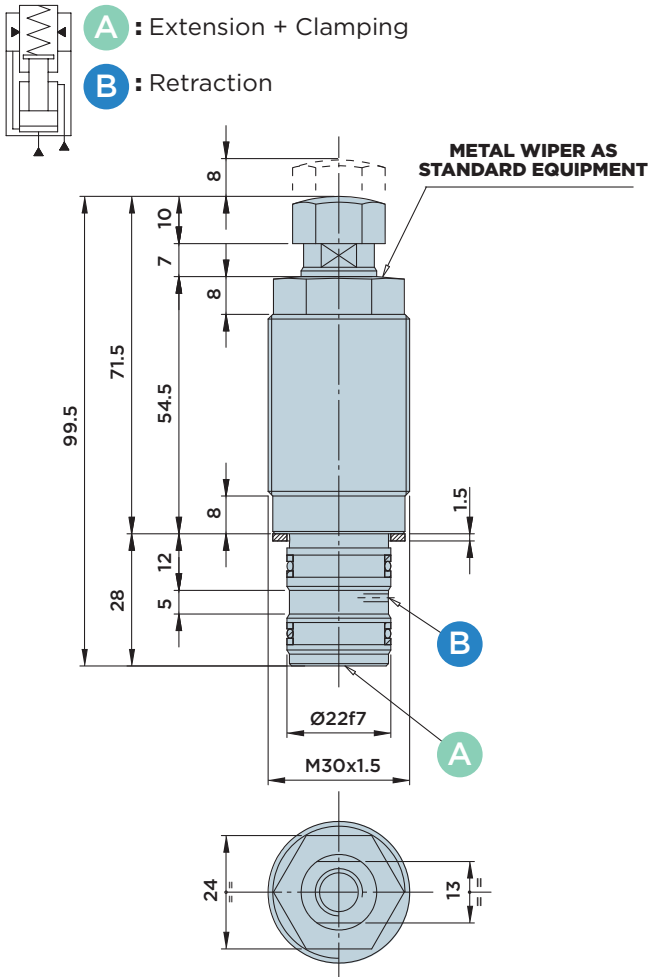

INSTALLATION DIMENSIONS

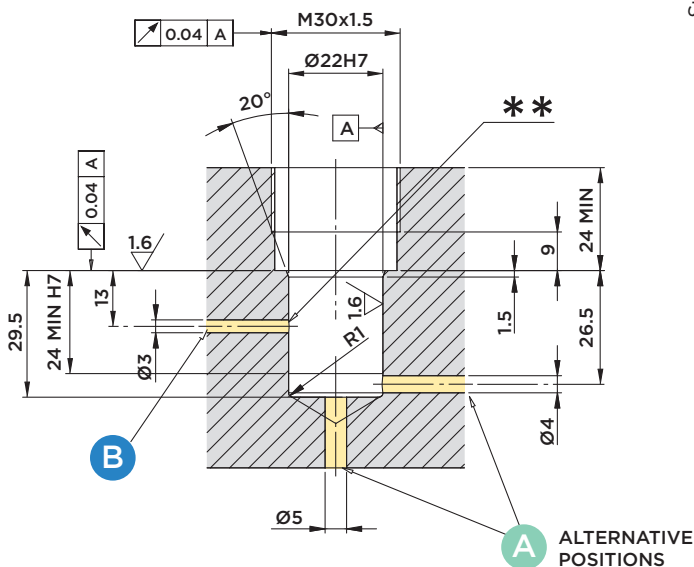

** Deburr and round off any edges

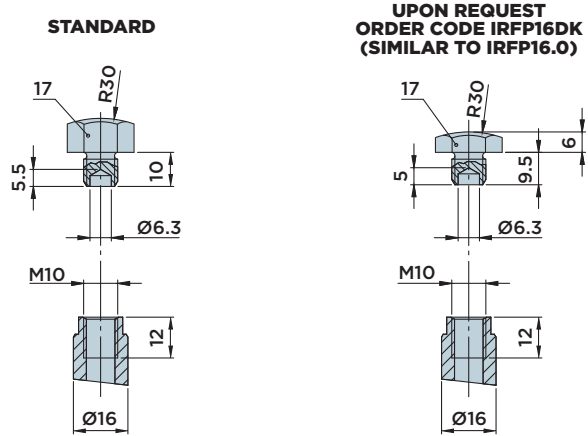

FORCE/PRESSURE/DEFLECTION DIAGRAM

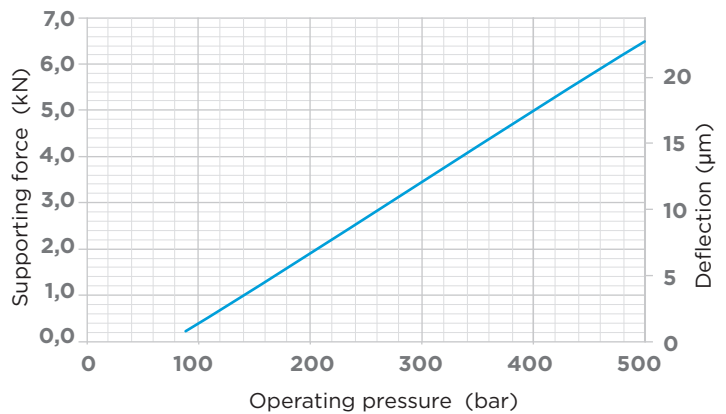

Note:

The maximum admissible flow rate amounts to 1.5 l/min.

Contact force:

- Standard 15÷35 N
- Upon request 10÷20 N (order no. IRFP16.8DL)

Included in the scope of supply:

- Sealing ring Ø22xØ28x1.5

Material:

- Piston/rod: Case-hardened steel, ground.
- Body: Free machining steel, nitrocarburized.

Options:

The cylinder is also available with thin pressure pad h=6mm (see IRFP16.8DK)



HYDROBLOCK

IRFP 16.8LD

HYDRAULIC WORK SUPPORT WITH **UPPER FLANGE DOUBLE-ACTING**

MAX. OPERATING PRESSURE = 500BAR

A : Extension + Clamping

B : Retraction

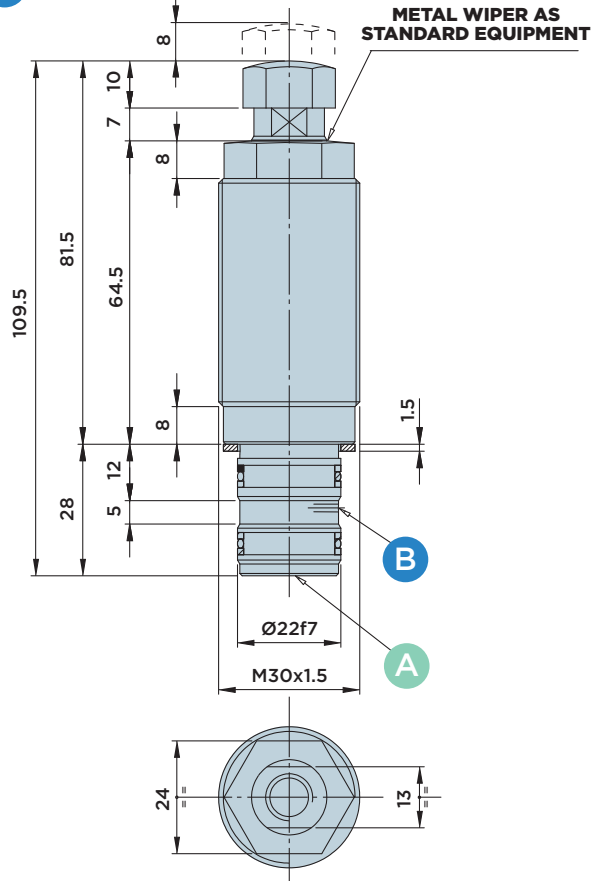

INSTALLATION DIMENSIONS

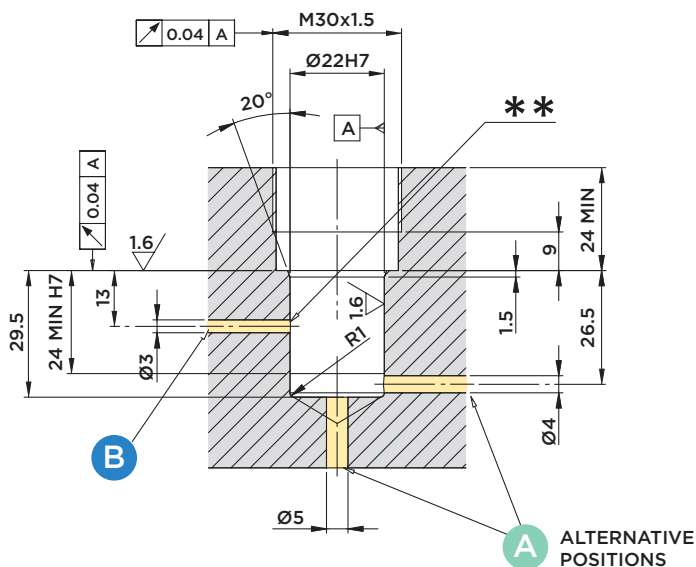

** Debur and round off any edges

STANDARD

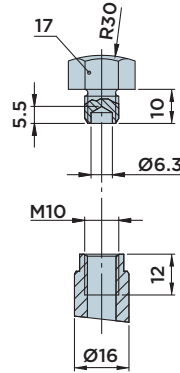

UPON REQUEST ORDER CODE IRFP16LDK (SIMILAR TO IRFP16.0)

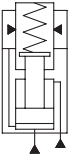
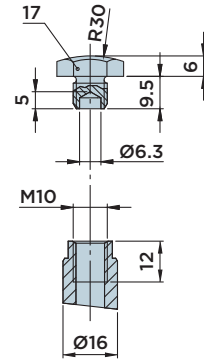

FORCE/PRESSURE/DEFLECTION DIAGRAM

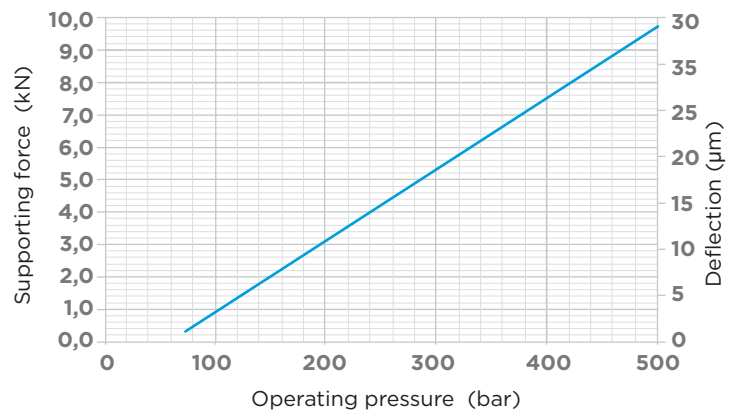

Note:

The maximum admissible flow rate amounts to 1.5 l/min.

Contact force:

- Standard 15÷35 N
- Upon request 10÷20 N (order no. IRFP16.8DL)

Included in the scope of supply:

- Sealing ring Ø22xØ28x1.5

Material:

- Piston/rod: Case-hardened steel, ground.
- Body: Free machining steel, nitrocarburized.

Options:

The cylinder is also available with thin pressure pad h=6mm (see IRFP16.8DK).

IRFP 16.15D

HYDRAULIC WORK SUPPORT WITH **UPPER FLANGE DOUBLE-ACTING**

MAX. OPERATING PRESSURE = 500BAR

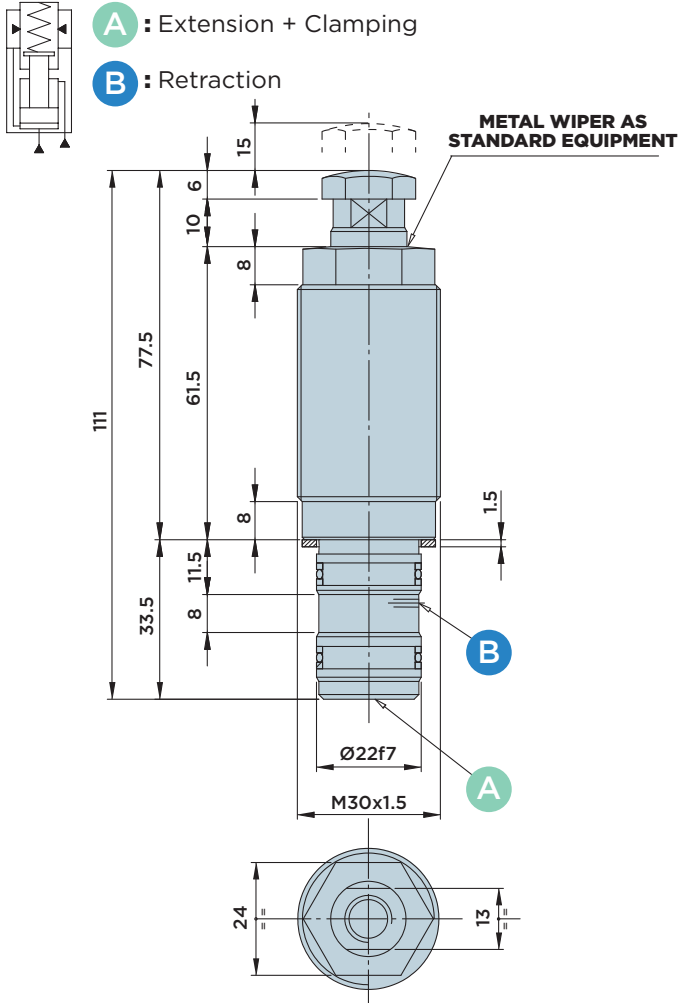

INSTALLATION DIMENSIONS

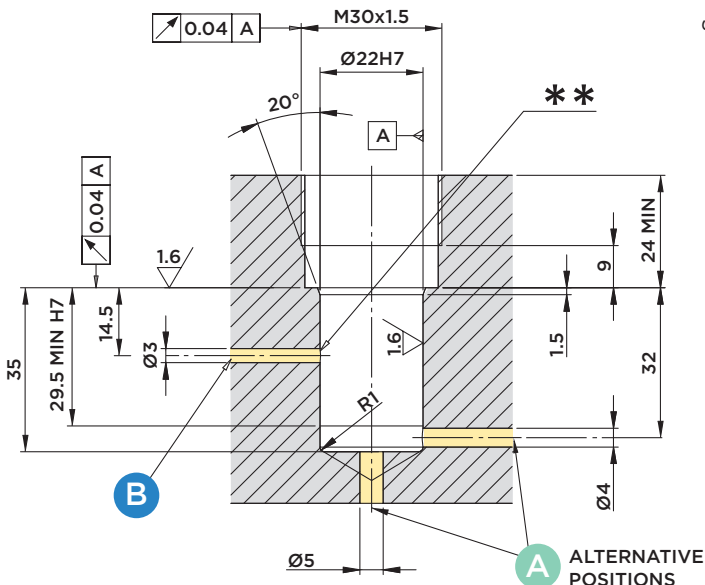

IRFP16.15D / IRFP 16.15LD

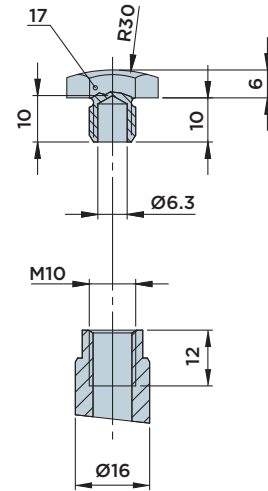

FORCE/PRESSURE/DEFLECTION DIAGRAM

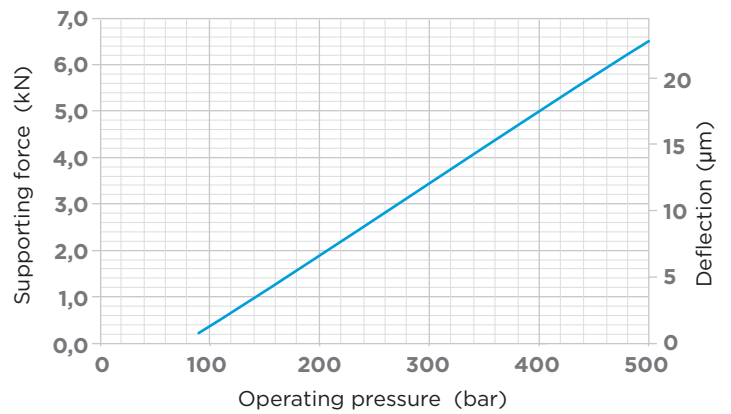

Note:

The maximum admissible flow rate amounts to 1.5 l/min.

Contact force:

- Standard 10÷22 N

Included in the scope of supply:

- Sealing ring Ø22xØ28x1.5

Material:

- Piston/rod: Case-hardened steel, ground.
- Body: Free machining steel, nitrocarburized.

IRFP 16.15LD

HYDRAULIC WORK SUPPORT WITH **UPPER FLANGE DOUBLE-ACTING**

MAX. OPERATING PRESSURE = 500BAR

A : Extension + Clamping

B : Retraction

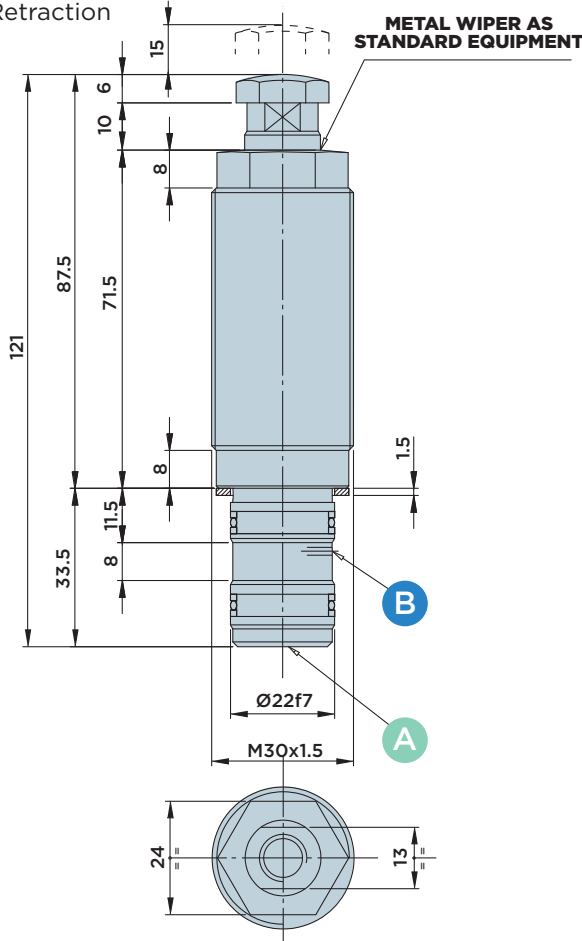

INSTALLATION DIMENSIONS

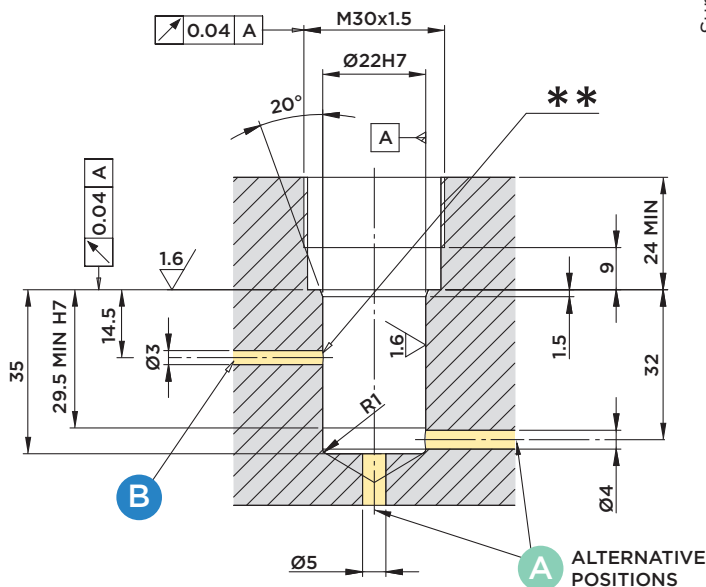

** Deburr and round off any edges

IRFP16.15D / IRFP 16.15LD

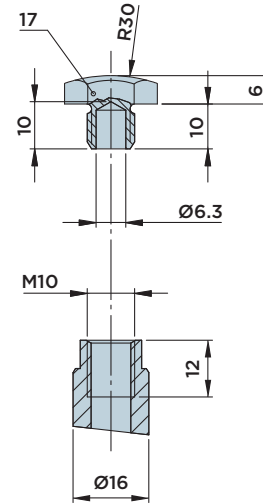

FORCE/PRESSURE/DEFLECTION DIAGRAM

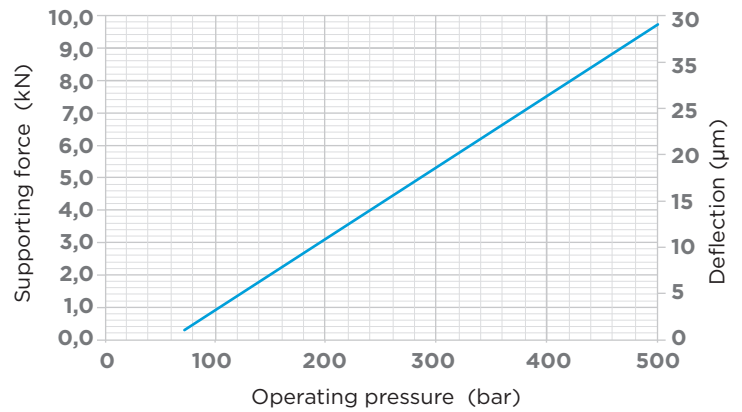

Note:

The maximum admissible flow rate amounts to 1.5 l/min.

Contact force:

- Standard 10±22 N

Included in the scope of supply:

- Sealing ring Ø22xØ28x1.5

Material:

- Piston/rod: Case-hardened steel, ground.
- Body: Free machining steel, nitrocarburized.

IR HYDRAULIC WORK SUPPORTS

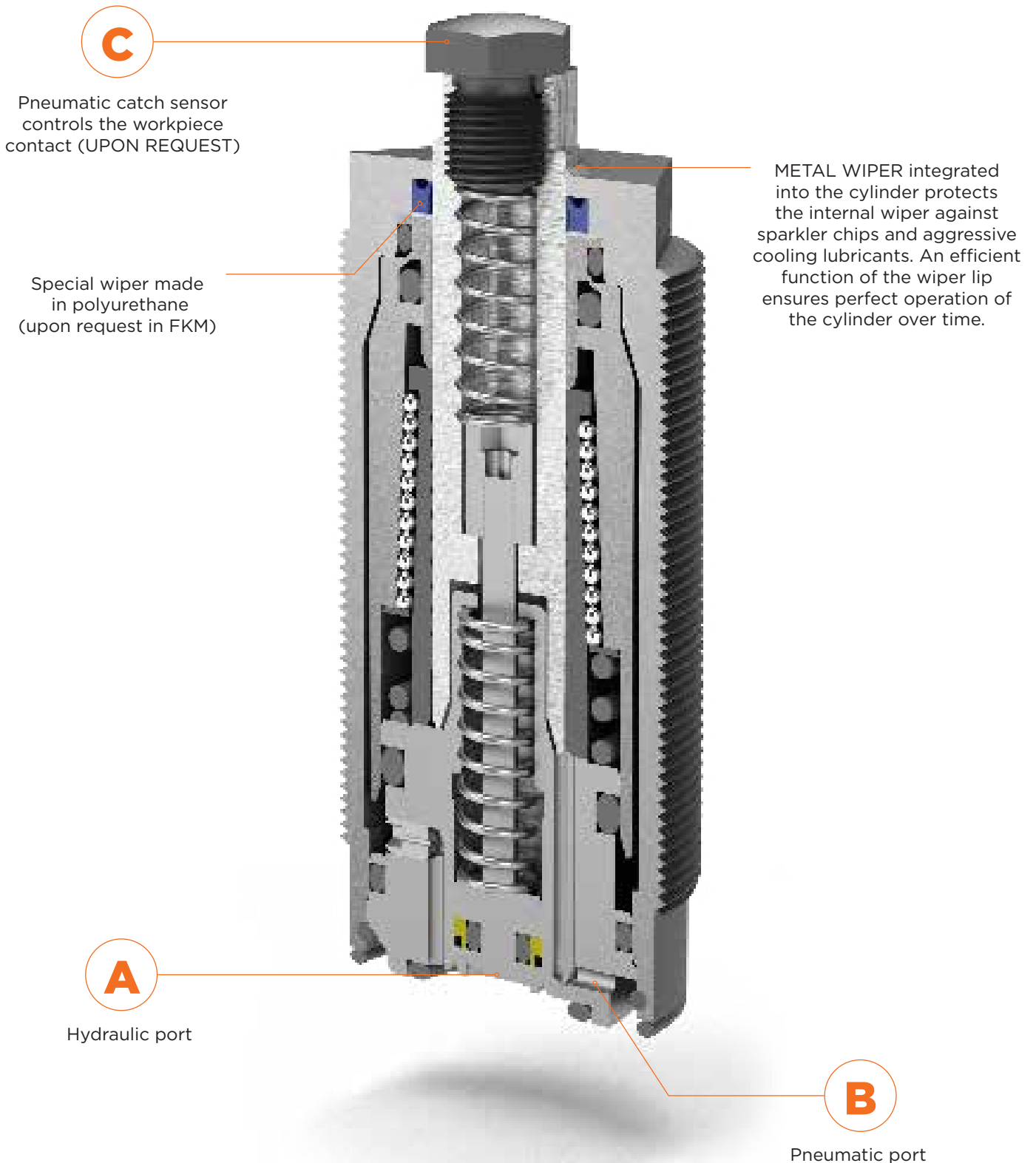

LOW PRESSURE

A. HYDRAULIC SUPPLY

The hydraulic circuit must be properly purged to ensure smooth operation of the hydraulic work supports. In addition, the supply flow must be below the maximum admissible flow rate specified for the component. IRF 70 work supports are rated for medium hydraulic pressures (max. 70 bar).

Excessively high pressure would cause damage to the mechanical parts inside the cylinder. Hydraulic circuits with an excessively high residual pressure or with too high supply flows may involve irregular cylinder operation.

B. PNEUMATIC SUPPLY

The cylinder will only operate correctly if the pneumatic line is free and protected against the penetration of fluids, dirt and chips. We recommend pressurizing the cylinder chamber with filtered air at a low pressure (max. 0.2/0.3 bar) to achieve smooth operation of the work supports.

The pneumatic line also allows a pressure pad with calibrated bore to be installed, which - when in contact with the workpiece - will ensure correct approach and cylinder clamping in working position through the pressure switch (pneumatic control).

C. PNEUMATIC CONTROL (upon request)

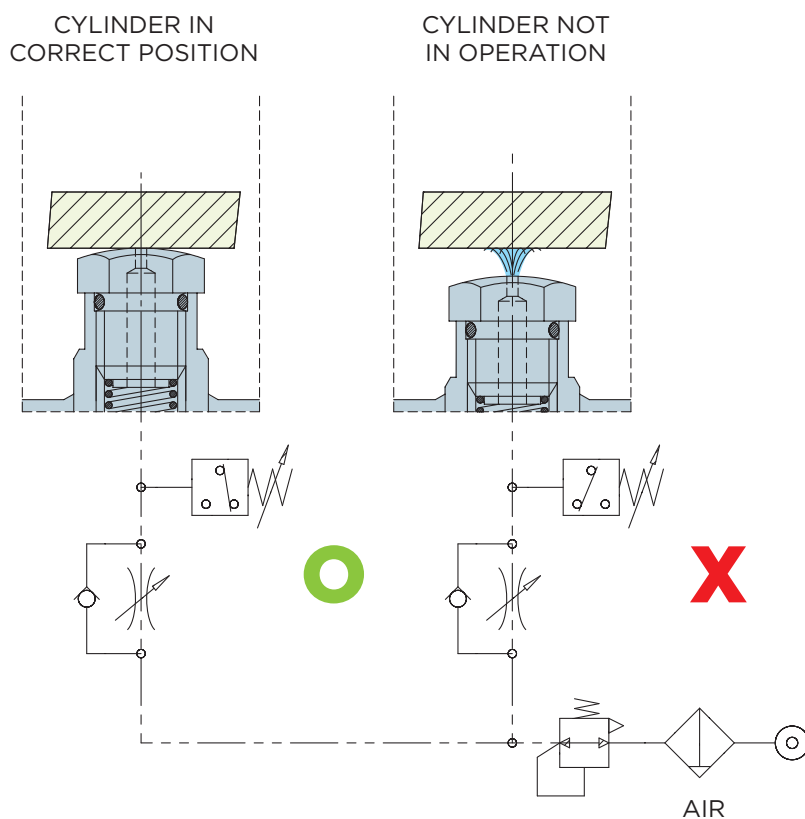

IRFP 10.70

HYDRAULIC WORK SUPPORT WITH **THREADED BODY**

MAX. OPERATING PRESSURE = 70BAR

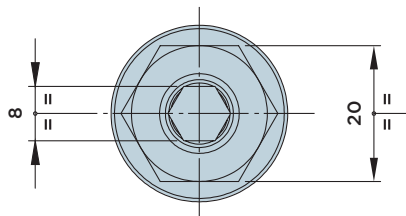
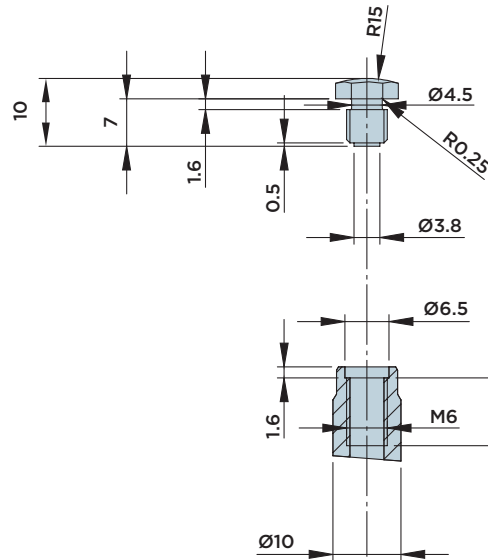
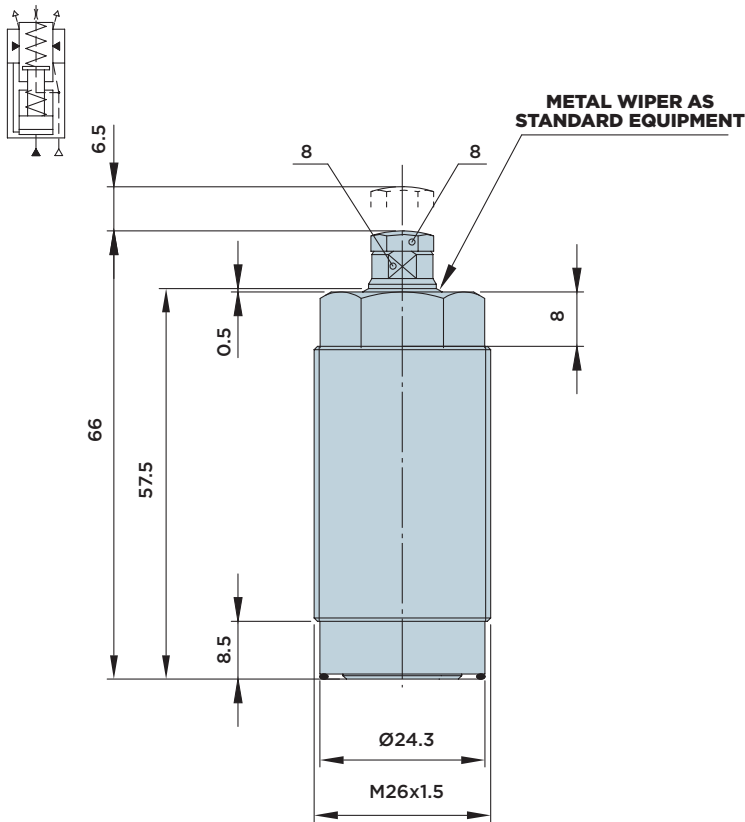

INSTALLATION DIMENSIONS

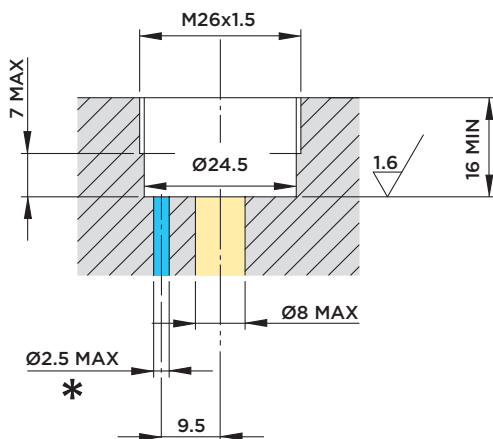

* Pneumatic supply: see page 281.

FORCE/PRESSURE/DEFLECTION DIAGRAM

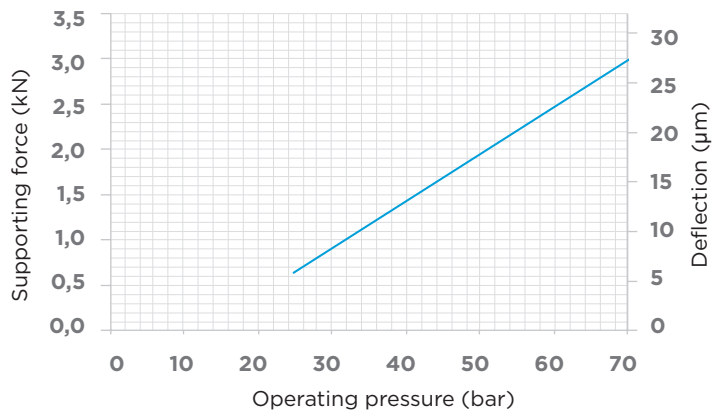

Note:

The maximum admissible flow rate amounts to 1.5 l/min.

Contact force:

- Standard 16±12 N
- Upon request 10±15 (order no. IRFP10.70S)
- Upon request 14±25 (order no. IRFP10.70H)

Included in the scope of supply:

- O-Ring Ø12.42x1.78
- O-Ring Ø22x1.3

Material:

- Piston/rod: Case-hardened steel, ground.
- Body: Free machining steel, nitrocarburized.

IRFM 10.70

HYDRAULIC WORK SUPPORT WITH **THREADED BODY**

MAX. OPERATING PRESSURE = 70BAR

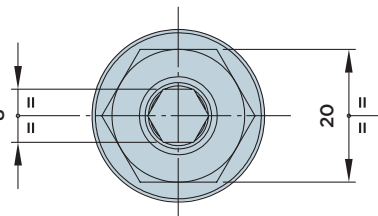
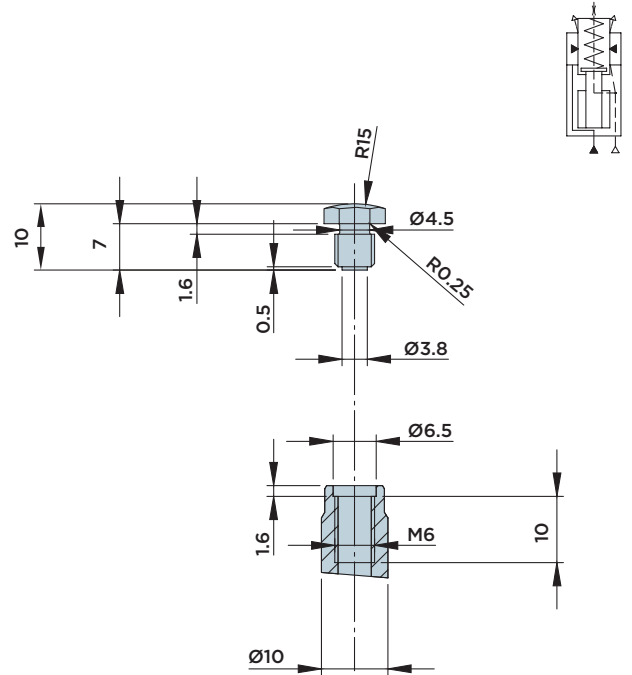
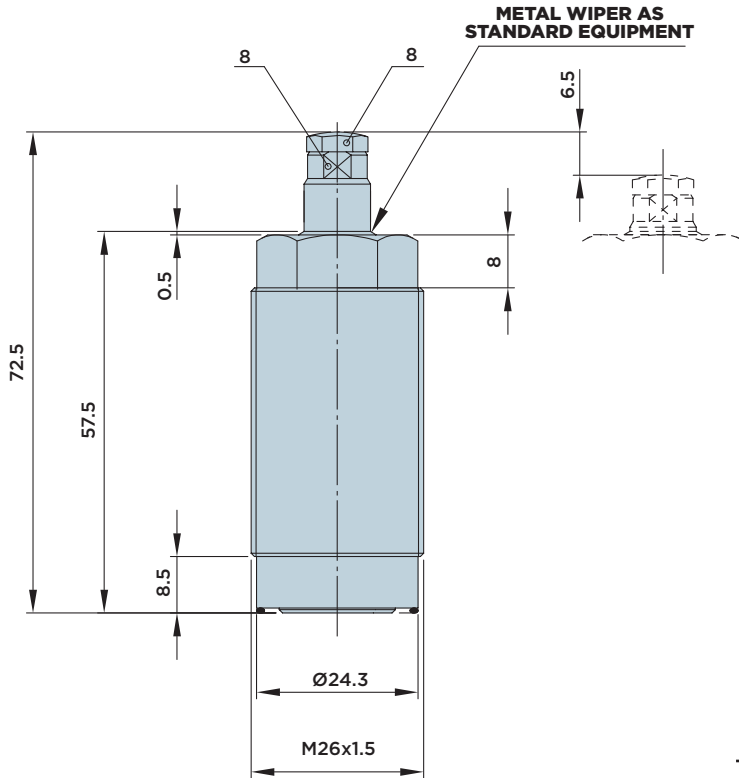

INSTALLATION DIMENSIONS

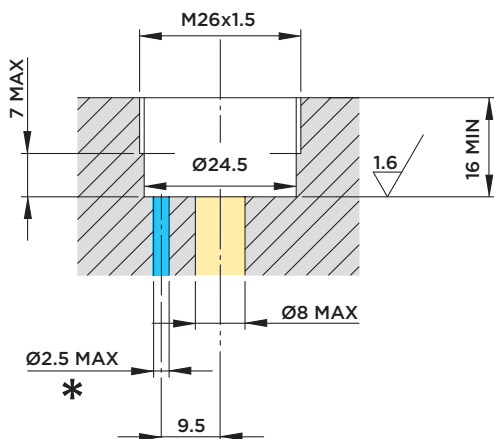

* Pneumatic supply: see page 281.

FORCE/PRESSURE/DEFLECTION DIAGRAM

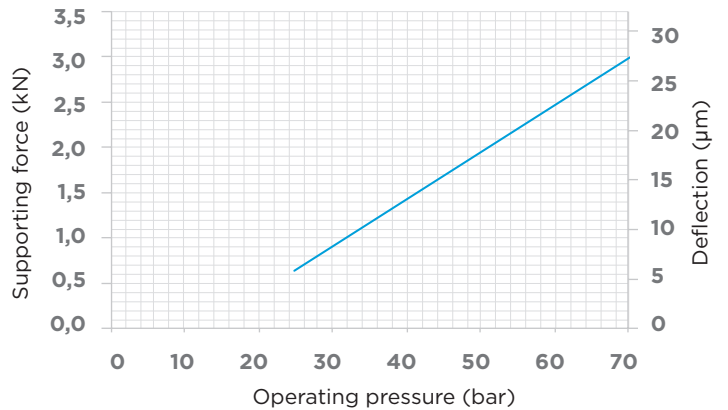

Note:

The maximum admissible flow rate amounts to 1.5 l/min.

Contact force:

- Standard 16÷12 N
- Upon request 10÷15 (order no. IRFM10.70S)
- Upon request 14÷25 (order no. IRFM10.70H)

Included in the scope of supply:

- O-Ring Ø12.42x1.78
- O-Ring Ø22x1.3

Material:

- Piston/rod: Case-hardened steel, ground.
- Body: Free machining steel, nitrocarburized.



HYDROBLOCK

IRFM 12.70

HYDRAULIC WORK SUPPORT WITH **THREADED BODY**

MAX. OPERATING PRESSURE = 70BAR

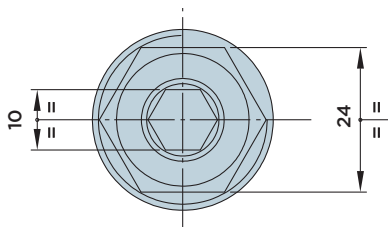
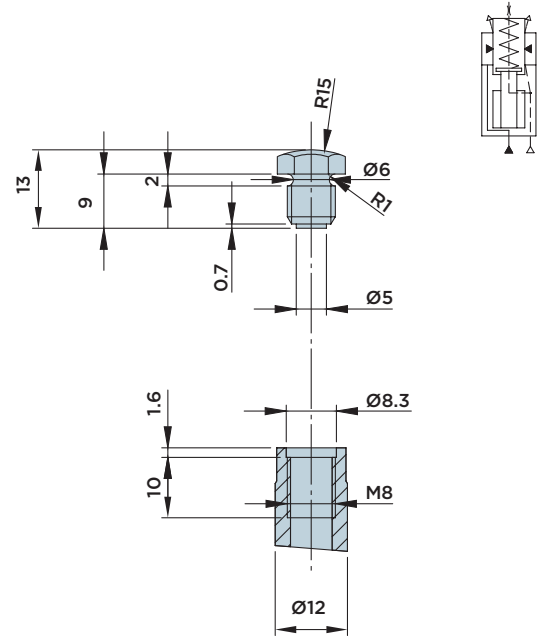
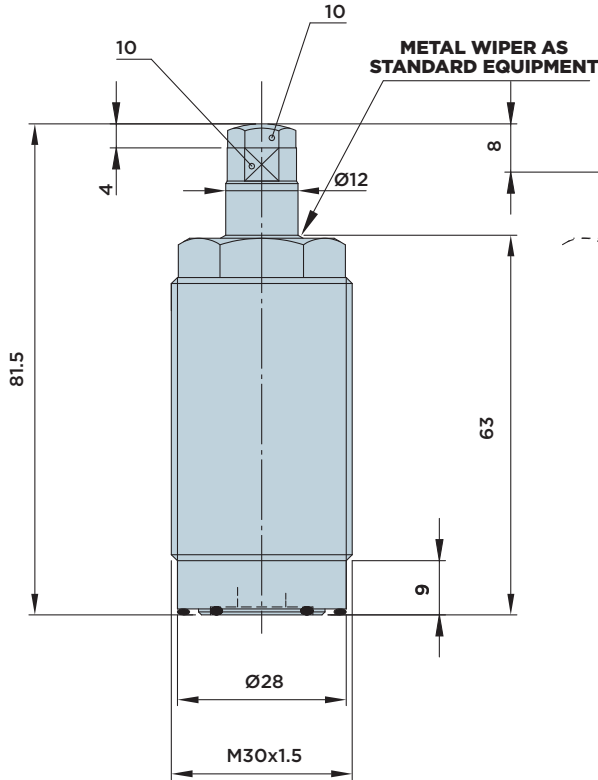

INSTALLATION DIMENSIONS

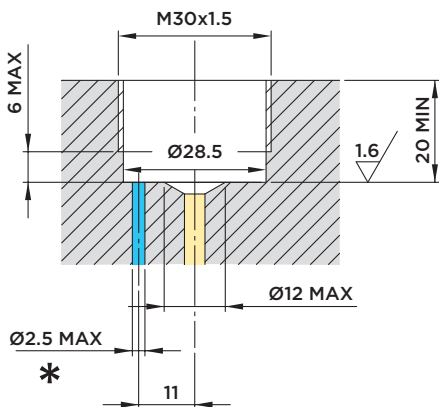

* Pneumatic supply: see page 281.

FORCE/PRESSURE/DEFLECTION DIAGRAM

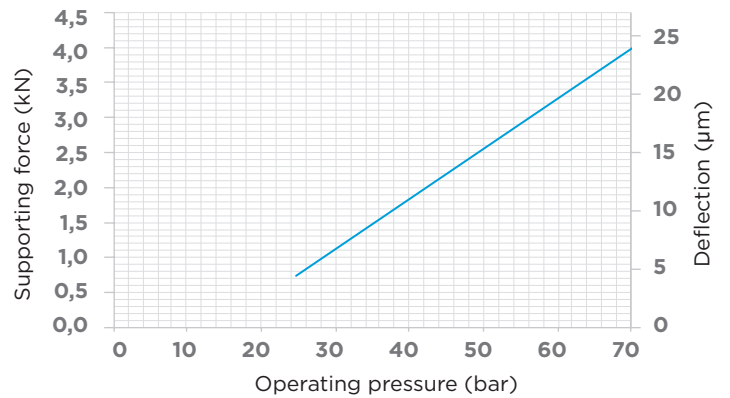

Note:

The maximum admissible flow rate amounts to 1.5 l/min.

Contact force:

- Standard 10÷16 N
- Upon request 14÷20 (order no. IRFM12.70S)
- Upon request 20÷40 (order no. IRFM12.70H)

Included in the scope of supply:

- O-Ring Ø14x1.78
- O-Ring Ø25.12x1.78

Material:

- Piston/rod: Case-hardened steel, ground.
- Body: Free machining steel, nitrocarburized.

IRFP 15.70

HYDRAULIC WORK SUPPORT WITH **THREADED BODY**

MAX. OPERATING PRESSURE = 70BAR

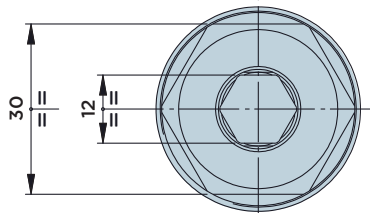
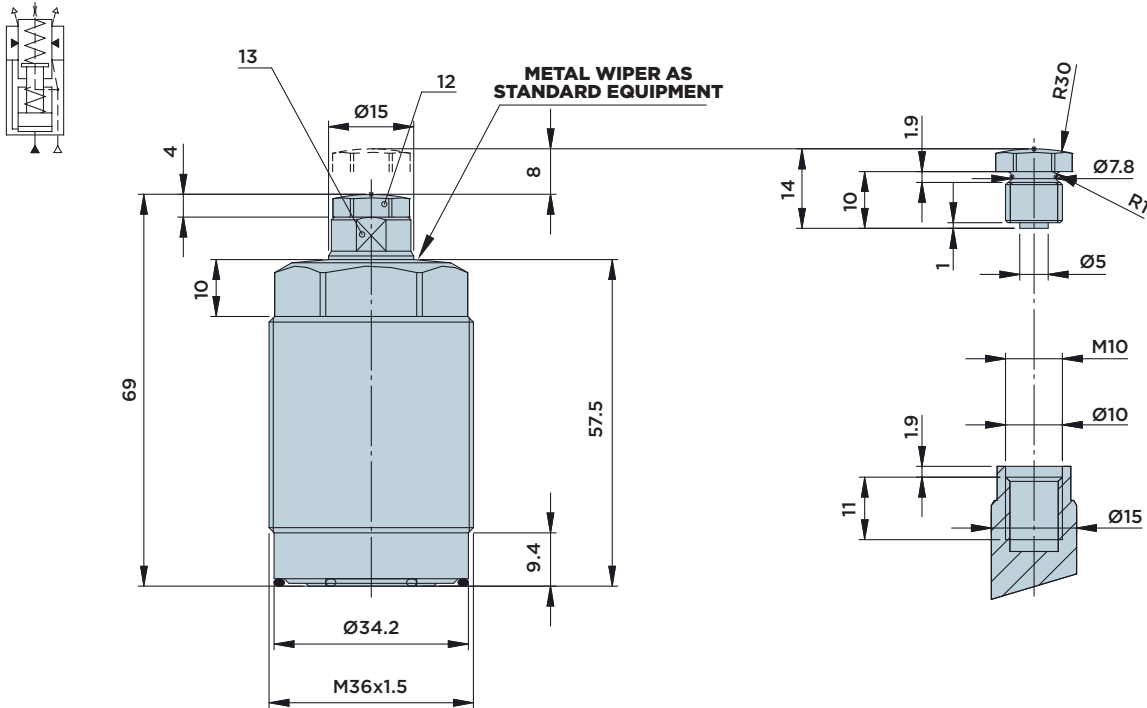

INSTALLATION DIMENSIONS

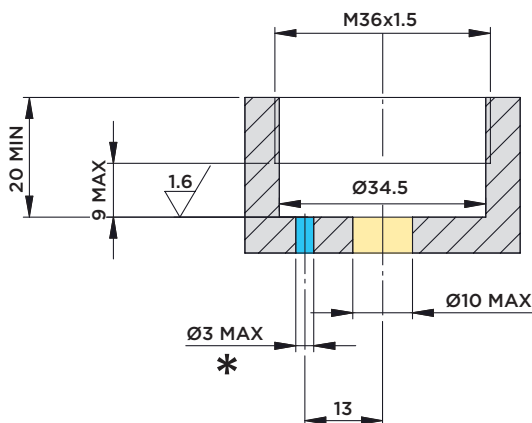

* Pneumatic supply: see page 281.

FORCE/PRESSURE/DEFLECTION DIAGRAM

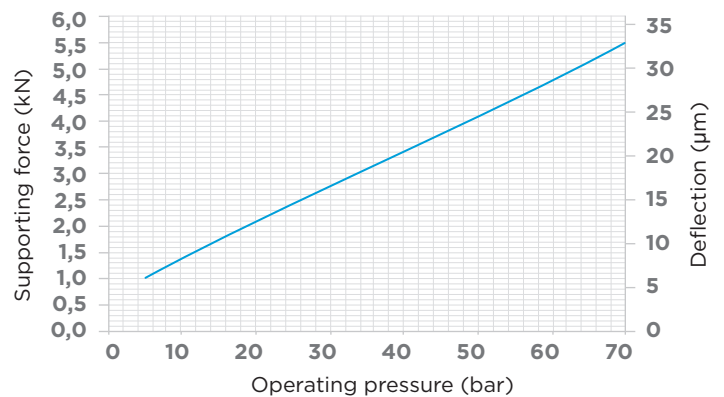

Note:

The maximum admissible flow rate amounts to 1.5 l/min.

Contact force:

- Standard 5÷8 N
- Upon request 6÷11 (order no. IRFP15.70H)

Included in the scope of supply:

- O-Ring Ø12.42x1.78
- O-Ring Ø31.42x1.78

Material:

- Piston/rod: Case-hardened steel, ground.
- Body: Free machining steel, nitrocarburized.

IRFM 15.70

HYDRAULIC WORK SUPPORT WITH **THREADED BODY**

MAX. OPERATING PRESSURE = 70BAR

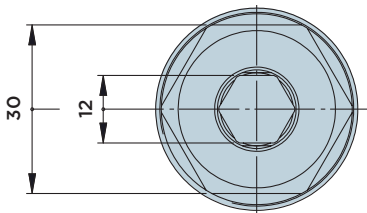
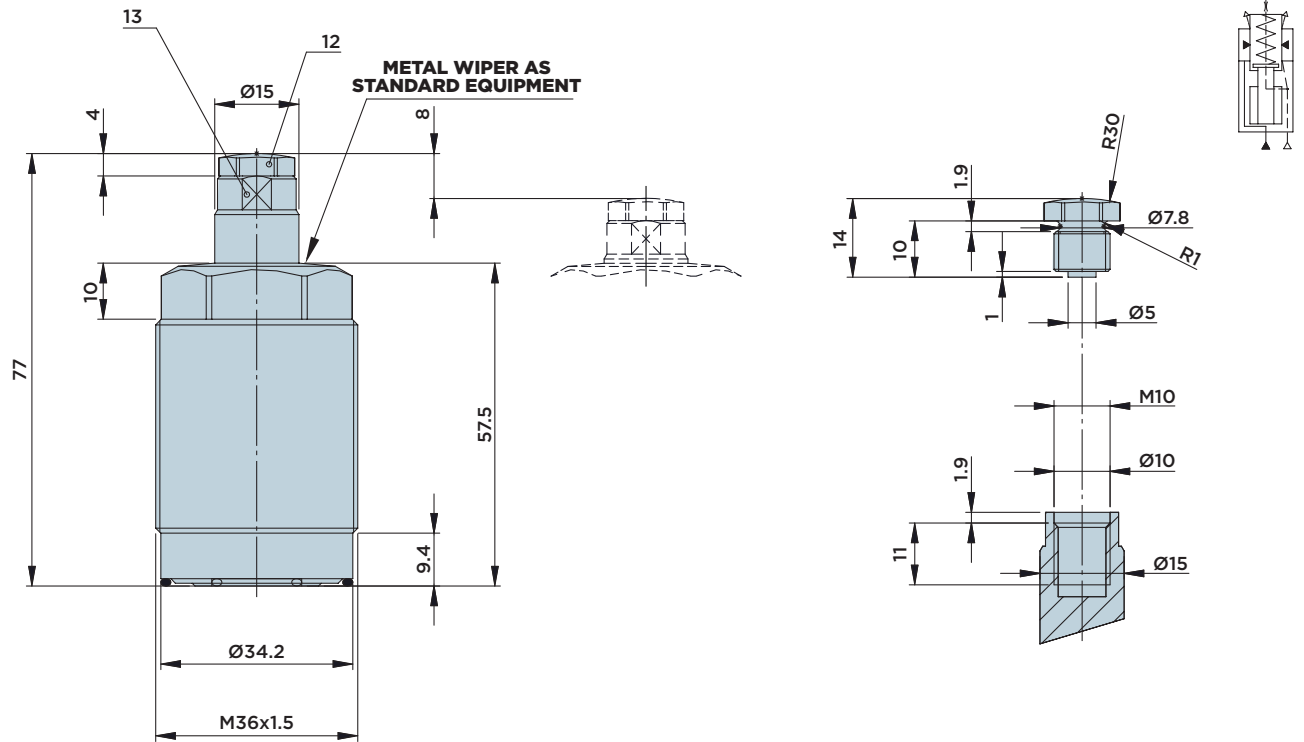

INSTALLATION DIMENSIONS

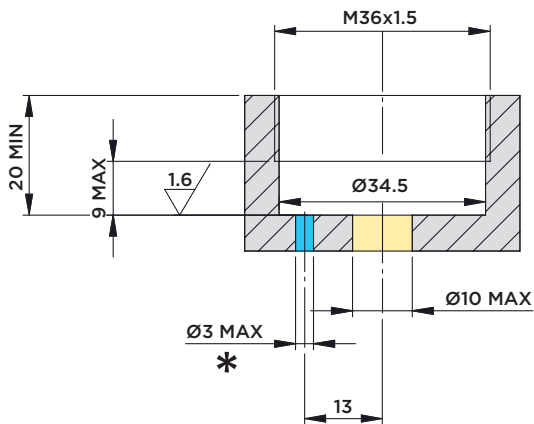

* Pneumatic supply: see page 281.

FORCE/PRESSURE/DEFLECTION DIAGRAM

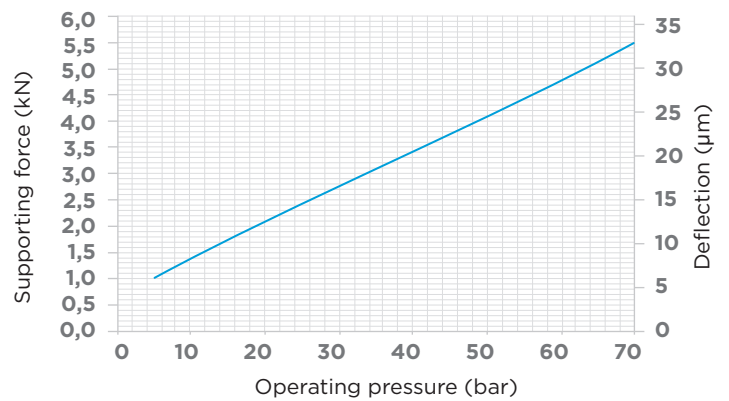

Note:

The maximum admissible flow rate amounts to 1.5 l/min.

Contact force:

- Standard 5÷8 N
- Upon request 6÷11 (order no. IRFM15.70H)

Included in the scope of supply:

- O-Ring Ø12.42x1.78
- O-Ring Ø31.42x1.78

Material:

- Piston/rod: Case-hardened steel, ground.
- Body: Free machining steel, nitrocarburized.

IR

HYDRAULIC WORK SUPPORTS OF SPECIAL DESIGN



HYDROBLOCK