

Sanitary, Single Passage Rotary Unions

SCS Series

HYGIENIC CLAMP FERRULE CONNECTION OPTIONS



Contents

- 3** What is a Rotary Union?
- 4** Overview
- 5** How To Order
- 6** Hygienic Clamp Ferrule Connection Options
- 7** Specifications & Operating Information
- 8** Performance Data
- 11** SCS ¾" Connection Dimensions
- 12** SCS 1" Connection Dimensions
- 13** SCS 1½" Connection Dimensions
- 14** SCS 2" Connection Dimensions
- 15** SCS 2½" Connection Dimensions
- 16** SCS 3" Connection Dimensions
- 17** SCS 4" Connection Dimensions
- 18** Installation & Mounting

About DSTI

Dynamic Sealing Technologies, Inc. (DSTI) serves a wide range of global industries as a leader in engineered fluid sealing and transfer solutions for rotating applications.

DSTI core business segments are fluid rotary unions, electrical slip rings, and value-added products and services—providing customers with a single-source solution from design and manufacturing through to testing and qualification—all under one roof. Located in North America and Europe with a team of distribution partners and technical support specialists worldwide.



DID YOU KNOW?

DSTI Exports Products to Over 60 Countries.

What is a Rotary Union?

A rotary union (or swivel joint) is a mechanism used to transfer fluid (under pressure or vacuum) from a stationary inlet to a rotating outlet, preserving and isolating the fluid connection.

Rotary unions are engineered to endure a wide range of temperatures and pressures for a variety of conditions and environments. In addition, rotary unions may integrate multiple passages and handle different types of fluid simultaneously.

HOW DO I CHOOSE THE BEST ROTARY UNION FOR MY APPLICATION?

Tell us about your requirements so we can make a recommendation:

- 1) Type of media(s) / fluid(s) to be transferred
- 2) Number of independent flow channels (passages)
- 3) Operating pressure
- 4) Operating temperature
- 5) Operating speed
- 6) Shaft & housing connection type
- 7) Flow channel (passage) size
- 8) Torque & load requirements
- 9) Duty cycle*

**Does the temperature, speed or pressure fluctuate or change during operation? If so, please provide the detailed ranges for each parameter and time durations of each condition.*

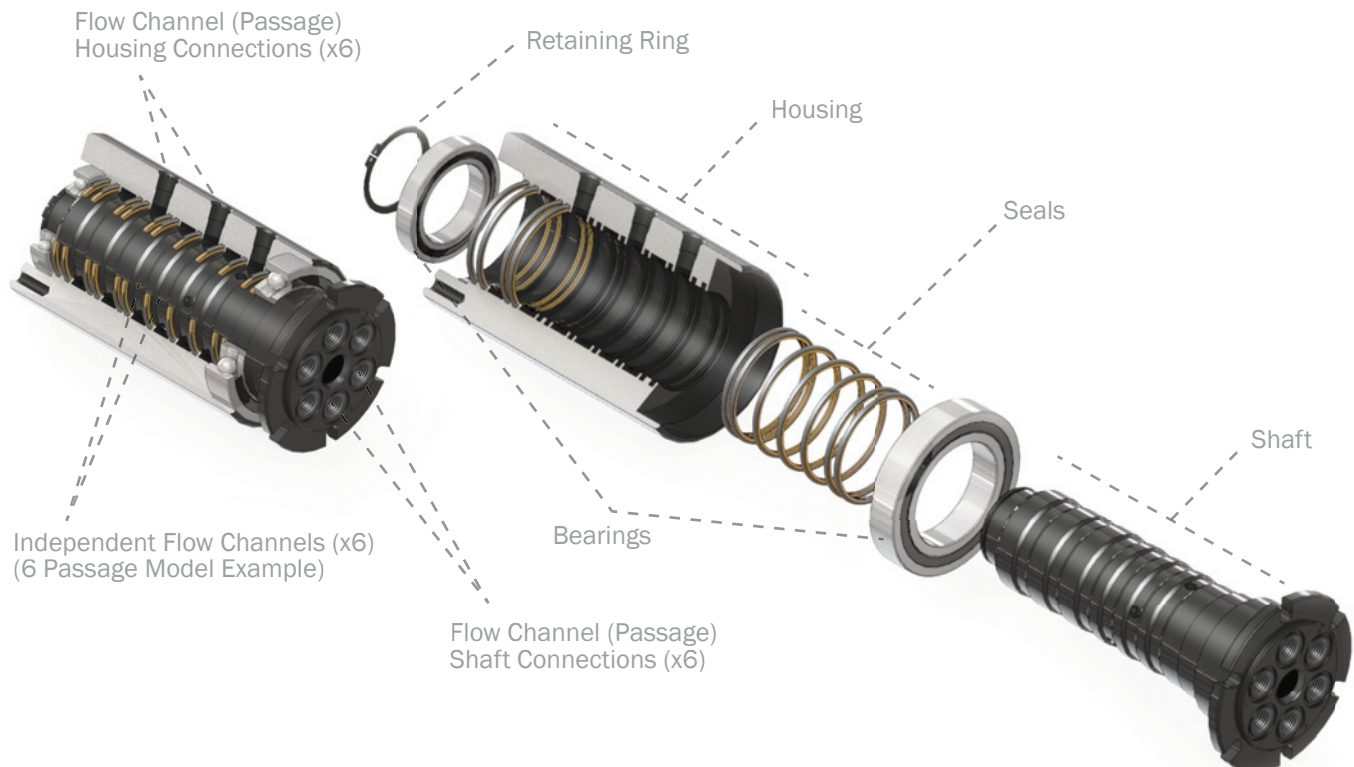

Overview



- + Hygienic Clamp Ferrule Connections
- + FDA Compliant Materials For Use With CIP (Clean-in-Place) Systems
- + Food Grade Seals and Bearing Lubricant
- + Engineered to Minimize Fluid Stagnation Points
- + Exclusive DSTI Sealing Technology
- + 316 Stainless Steel Shaft and Housing
- + ASME-BPE & DIN 32676 Connections Available

The single passage SCS Series rotary unions feature hygienic, tri-clamp ferrule connections, food grade seals and bearing lubricant, and a FDA-approved design for use with CIP (Clean-in-Place) systems.

To help minimize fluid stagnation points, smooth flow lines are engineered into the design to allow a clear passage for fluid. Specialized bearings fit inside a sealed chamber to keep lubricants in and contaminants out.

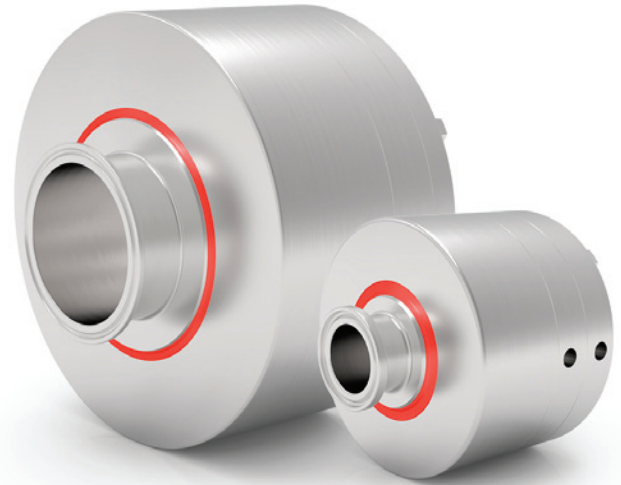

The all-stainless steel SCS Series utilize high performance DSTI sealing technology and are available with either ASME-BPE or DIN 32676 connections.

If needed, DSTI can make modifications to meet each application's specific requirements including changes to the SCS Series mounting configuration, connections, sealing system, and housing or shaft dimensions.

How to Order: Create your Part Number

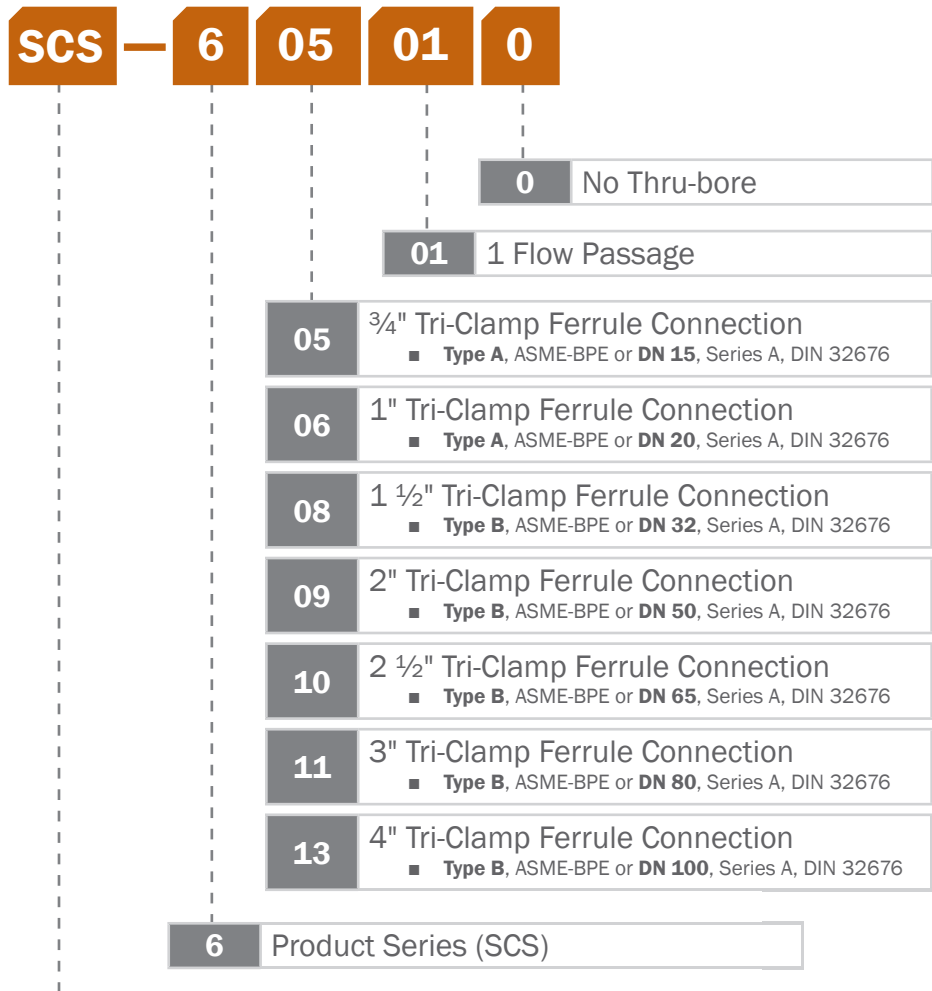

NOTE
Thru-bore option is not available.

NOTE
All SCS Series models contain 1 passage.

PART NUMBER EXAMPLES

SCS-605010

- SCS 1-Passage, 3/4" Type A ASME-BPE Connections

SCS-613010

- SCS 1-Passage, 4" Type B ASME-BPE Connection passage

SCSM-609010

- SCS 1-Passage, 2" DN 50, Series A, DIN 32676 Connection

SEE PAGE 6 FOR MORE DETAILS

SCS	SCS Series (Type A or B, ASME-BPE Connection)
SCSM	SCS Series (Series A, DIN 32676)

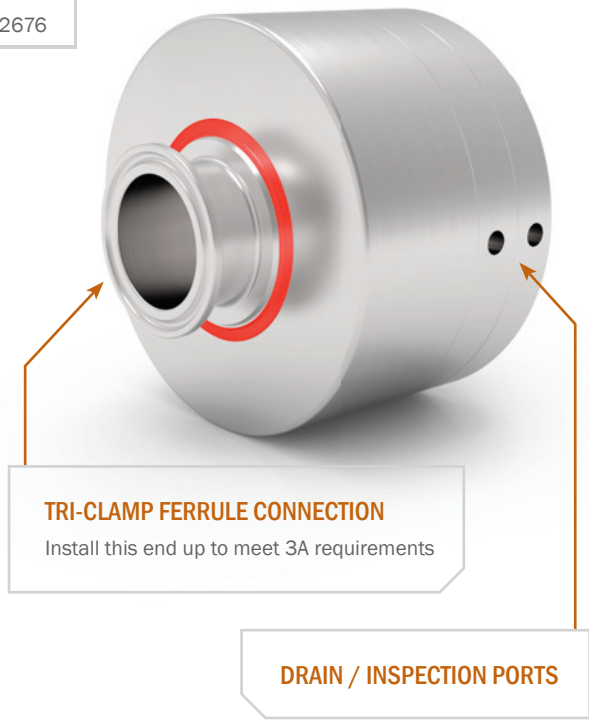

Hygienic Clamp Ferrule Connection Options

TYPE A, ASME BPE-2009

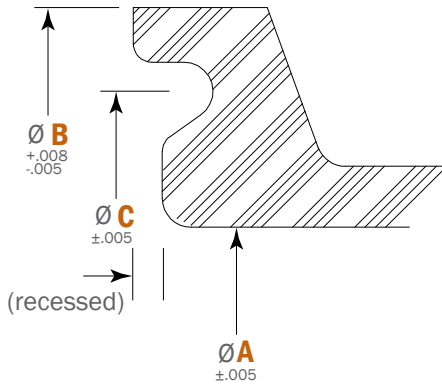

TYPE B, ASME BPE-2009

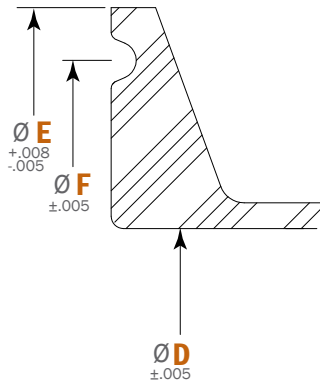

SERIES A, DIN 32676

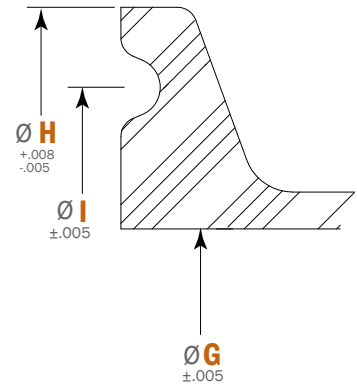

SIZE	A	B	C
.75"	0.620" [15.75mm]	0.984" [25mm]	0.800" [20.32mm]
1"	0.870" [22.1mm]	1.339" [34mm]	1.160" [29.46mm]

SIZE	D	E	F
1.5"	1.37" [34.8mm]	1.984" [50.39mm]	1.718" [43.64mm]
2"	1.87" [47.5mm]	2.516" [63.91mm]	2.218" [56.34mm]
2.5"	2.37" [60.2mm]	3.047" [77.4mm]	2.781" [70.64mm]
3"	2.87" [72.9mm]	3.579" [90.91mm]	3.281" [83.34mm]
4"	3.834" [97.4mm]	4.682" [119mm]	4.344" [110.3mm]

SIZE	G	H	I
DN 15	0.630" [16mm]	1.339" [34mm]	1.083" [27.5mm]
DN 20	0.787" [20mm]	1.339" [34mm]	1.083" [27.5mm]
DN 32	1.260" [32mm]	1.988" [50.5mm]	1.713" [43.5mm]
DN 50	1.969" [50mm]	2.520" [64mm]	2.224" [56.49mm]
DN 65	2.598" [66mm]	3.583" [91mm]	3.287" [83.49mm]
DN 80	3.189" [81mm]	4.173" [106mm]	3.819" [97mm]
DN 100	3.937" [100mm]	4.685" [119mm]	4.331" [110mm]

PART NUMBER EXAMPLES

SCS-605010

- SCS 1-Passage, 3/4" Type A ASME-BPE Connections

PART NUMBER EXAMPLES

SCS-613010

- SCS 1-Passage, 4" Type B ASME-BPE Connections

PART NUMBER EXAMPLES

SCSM-609010

- SCS 1-Passage, DN 50, Series A, DIN 32676 Connection

Specifications & Operating Information

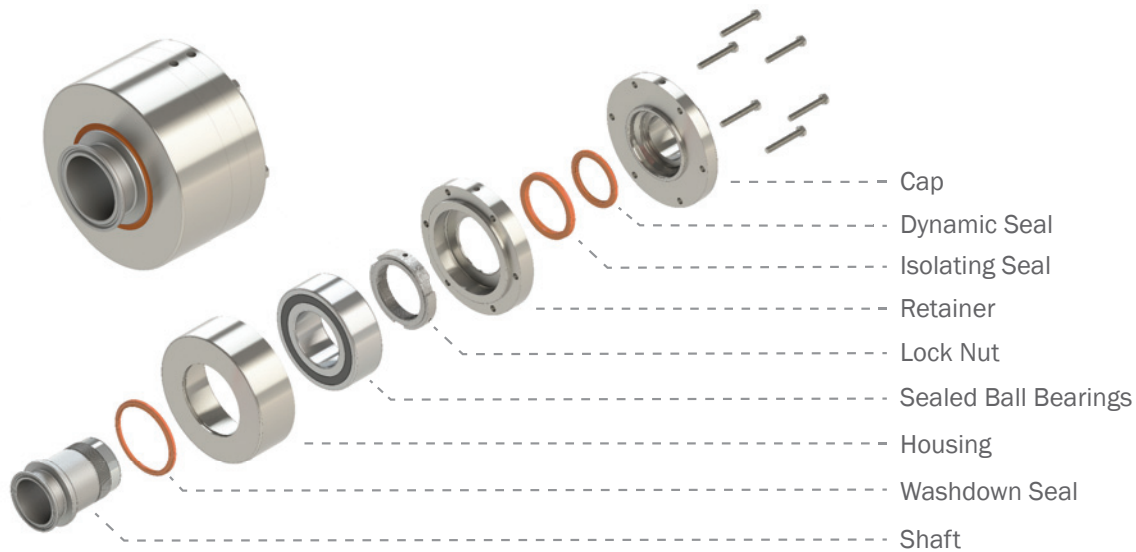

Flow Passages	
Media Types	Air/Gas, Chemical, DI/Tap Water, Food-Grade, Water/Glycol
Passage Sizes	$\frac{3}{4}$ ", 1", 1 $\frac{1}{2}$ ", 2", 2 $\frac{1}{2}$ ", 3", 4"
Connection Type	Type A or B ASME BPE-2009 (Series A, per DIN 32676)
Max. Operating Pressure	200 PSI (14 BAR) ¹
Max. Vacuum	24 HG ¹
Max. Rotational Speed	500 RPM ²
Operating Temperature	0° F to 220° F (-18° C to 105° C) ³
Body Material Type	316 Stainless Steel
Slip Ring Options	Not Applicable
Mounting Options	The SCS Series rotary unions connect at the ferrule clamp connection inlet and outlet.

¹ Values are dependent on a combination of all application parameters. Please consult with DSTI.

² Consult with DSTI for specific speed and pressure evaluation based on application.

³ High temperature applications may require alternative seal materials. Please consult with DSTI.

Performance Data: Pressure vs. Allowable Speed*

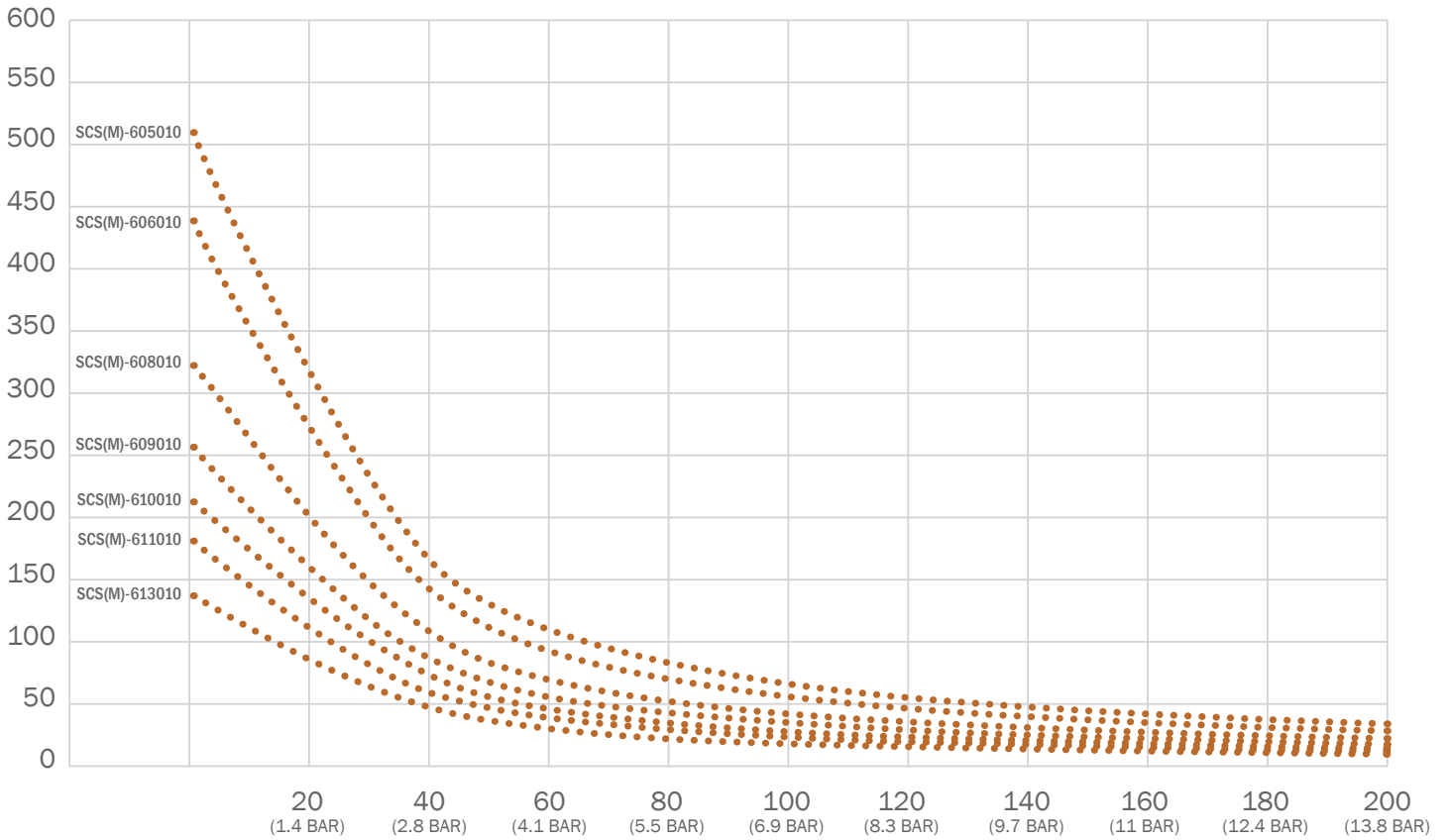

* This data is to be used as a general guideline. Data based on generic liquid food grade media as the media type. Please consult DSTI about your specific application.

Performance Data: Pressure vs. Torque*

MODEL	PRESSURE PSI (BAR)					
	0	20 (1.4 BAR)	40 (2.8 BAR)	60 (4.1 BAR)	80 (5.5 BAR)	100 (6.9 BAR)
SCS-605010	14.5 [1.64]	14.8 [1.67]	15.2 [1.72]	15.6 [1.76]	16.0 [1.81]	16.4 [1.85]
SCS-606010	28.5 [3.22]	28.8 [3.25]	29.2 [3.30]	29.6 [3.34]	30.0 [3.39]	30.4 [3.43]
SCS-608010	44.3 [5.01]	44.7 [5.05]	45.1 [5.10]	45.5 [5.14]	45.9 [5.19]	46.3 [5.23]
SCS-609010	43.6 [4.93]	44.0 [4.97]	44.4 [5.01]	44.8 [5.06]	45.2 [5.12]	45.6 [5.15]
SCS-610010	55.3 [6.25]	55.7 [6.29]	56.0 [6.33]	56.4 [6.37]	56.8 [6.42]	57.2 [6.46]
SCS-611010	79.3 [8.96]	79.7 [9.00]	80.1 [9.05]	80.5 [9.09]	80.9 [9.14]	81.2 [9.17]
SCS-613010	89.3 [10.08]	89.7 [10.13]	90.1 [10.18]	90.5 [10.23]	90.9 [10.27]	91.3 [10.32]
PRESSURIZED TORQUE (INCH POUND [NEWTON METER])						

MODEL	PRESSURE PSI (BAR)				
	120 (8.3 BAR)	140 (9.7 BAR)	160 (11 BAR)	180 (12.4 BAR)	200 (13.8 BAR)
SCS-605010	16.8 [1.90]	17.2 [1.94]	17.6 [1.99]	18.0 [2.03]	18.4 [2.08]
SCS-606010	30.8 [3.48]	31.2 [3.53]	31.6 [3.57]	32.0 [3.62]	32.4 [3.66]
SCS-608010	46.6 [5.27]	47.0 [5.31]	47.4 [5.36]	47.8 [5.40]	48.2 [5.45]
SCS-609010	45.9 [5.19]	46.3 [5.23]	46.7 [5.28]	47.1 [5.32]	47.5 [5.37]
SCS-610010	57.6 [6.51]	58.0 [6.55]	58.4 [6.60]	58.8 [6.64]	59.2 [6.69]
SCS-611010	81.6 [9.23]	82.0 [9.26]	82.4 [9.31]	82.8 [9.36]	83.2 [9.40]
SCS-613010	91.7 [10.36]	92.0 [10.39]	92.4 [10.44]	92.8 [10.48]	93.2 [10.53]
PRESSURIZED TORQUE (INCH POUND [NEWTON METER])					

* This data is to be used as a general guideline. Torque data represents the minimum torque required to rotate based on all passages (ports) pressurized with oil/hydraulic media. Required torque to rotate may be greater when using other media types or dry running. For specific torque requirements, please contact DSTI to discuss your application.

Performance Data: Frictional Loss at Allowable Speed at Pressure (btu/min)*

MODEL	PRESSURE PSI (BAR)					
	0	20 (1.4 BAR)	40 (2.8 BAR)	60 (4.1 BAR)	80 (5.5 BAR)	100 (6.9 BAR)
SCS-605010	5.01 [87.14]	3.22 [55.93]	1.65 [28.70]	1.13 [19.62]	0.87 [15.08]	0.71 [12.36]
SCS-606010	8.45 [146.97]	5.36 [93.12]	2.71 [47.19]	1.83 [31.88]	1.39 [24.22]	1.13 [19.63]
SCS-608010	9.70 [168.66]	6.12 [106.34]	3.09 [53.63]	2.07 [36.06]	1.57 [27.78]	1.27 [22.01]
SCS-609010	7.56 [131.41]	4.77 [82.87]	2.40 [41.80]	1.62 [28.11]	1.22 [21.27]	0.99 [17.16]
SCS-610010	7.93 [137.83]	4.99 [86.75]	2.51 [43.68]	1.69 [29.32]	1.27 [22.14]	1.03 [17.84]
SCS-611010	9.70 [168.66]	6.09 [105.93]	3.06 [53.22]	2.05 [35.65]	1.55 [26.87]	1.24 [21.60]
SCS-613010	8.31 [144.51]	5.22 [90.71]	2.62 [45.55]	1.75 [30.50]	1.32 [22.97]	1.06 [18.46]
FRICTIONAL LOSS (BTU PER MINUTE [WATTS])						

MODEL	PRESSURE PSI (BAR)				
	120 (8.3 BAR)	140 (9.7 BAR)	160 (11 BAR)	180 (12.4 BAR)	200 (13.8 BAR)
SCS-605010	0.61 [10.55]	0.53 [9.25]	0.48 [8.28]	0.43 [7.52]	0.40 [6.92]
SCS-606010	0.95 [16.57]	0.83 [14.38]	0.73 [12.74]	0.66 [11.47]	0.60 [10.44]
SCS-608010	1.06 [18.50]	0.92 [15.99]	0.81 [14.10]	0.73 [12.64]	0.66 [11.47]
SCS-609010	0.83 [14.97]	0.72 [12.91]	0.63 [11.38]	0.57 [10.18]	0.51 [9.22]
SCS-610010	0.86 [14.97]	0.74 [12.91]	0.65 [11.38]	0.59 [10.18]	0.53 [9.22]
SCS-611010	1.04 [18.09]	0.90 [15.58]	0.79 [13.69]	0.70 [12.23]	0.64 [11.06]
SCS-613010	0.89 [15.45]	0.76 [13.30]	0.67 [11.68]	0.60 [10.43]	0.54 [9.43]
FRICTIONAL LOSS (BTU PER MINUTE [WATTS])					

* This data is to be used as a general guideline. Please consult DSTI about your specific application.
 1 foot pound per minute (ft-lb/min) = 0.0013 btu per minute (btu/min) [0.023 watts (W)]

3/4" Connection: Dimensions

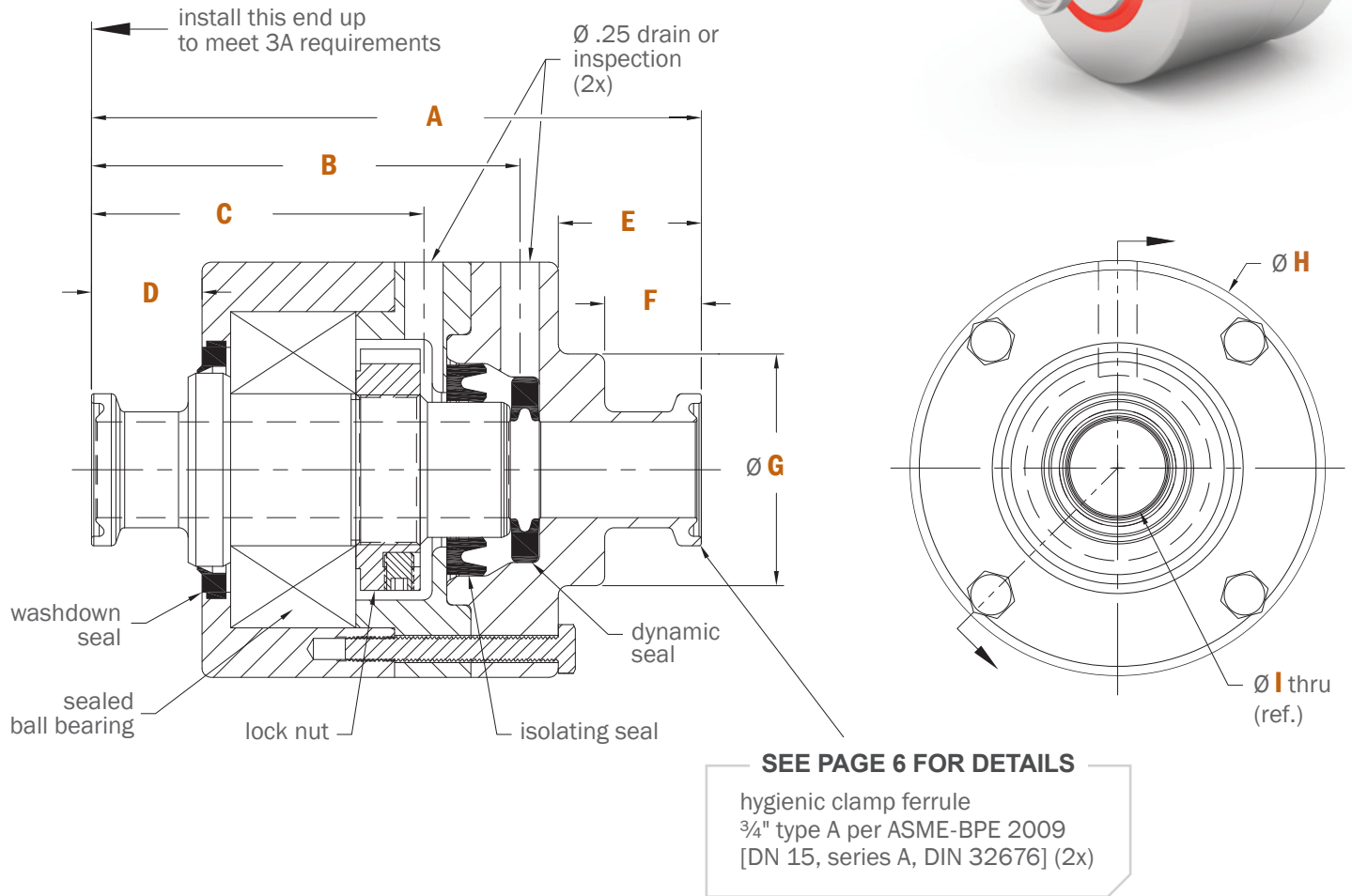
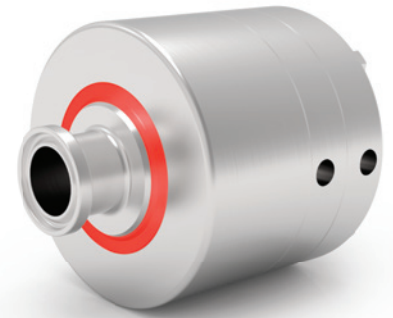

PART #	A	B	C	D	E	F	G	H	I
SCS-605010	3.95"	2.77"	2.15"	.72"	.93"	.63"	1.50"	2.69"	.62"
SCSM-605010	100.2mm	70.4mm	54.6mm	18.2mm	23.5mm	15.9mm	38.1mm	68.3mm	16.0mm

1" Connection: Dimensions

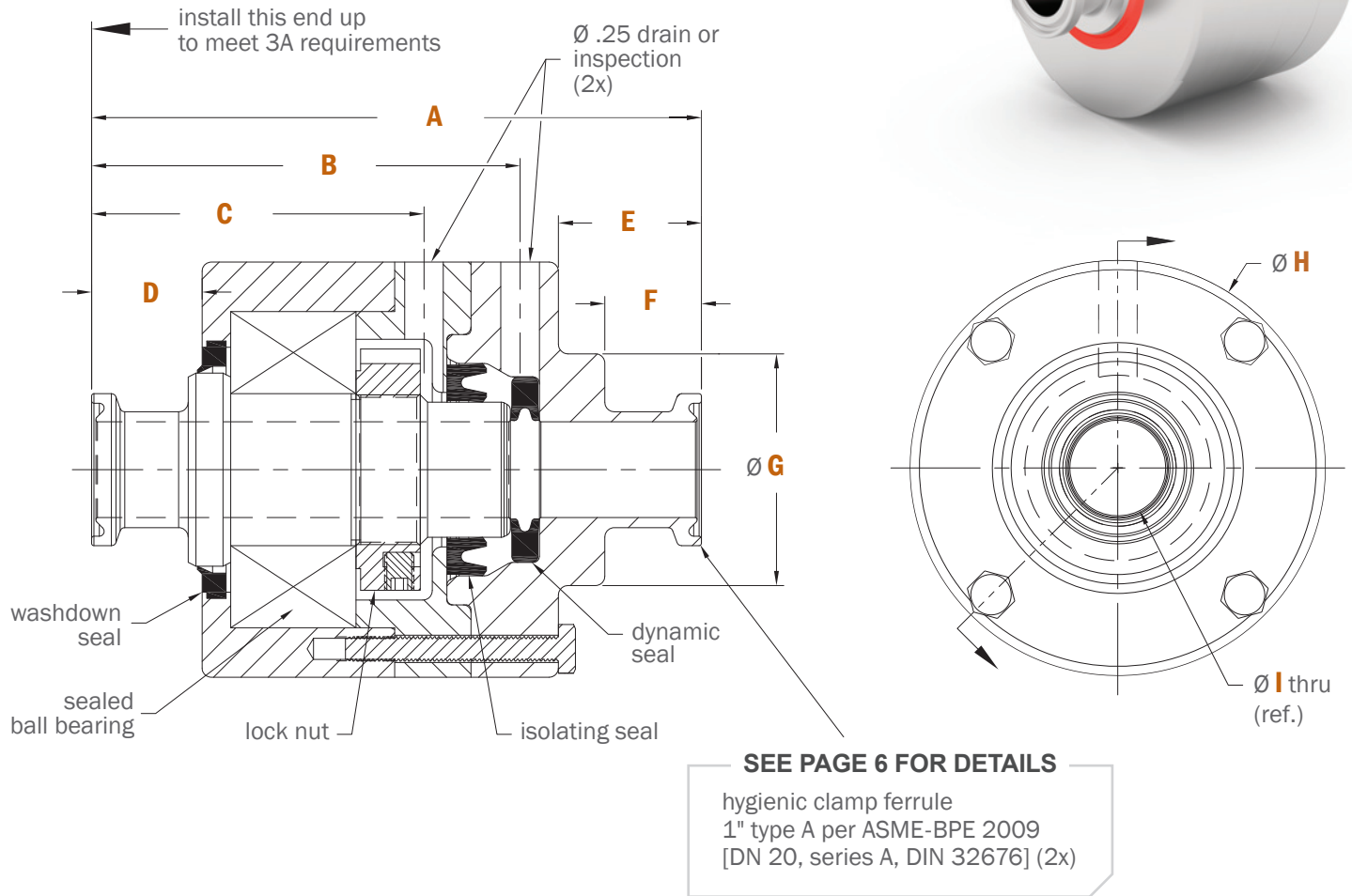
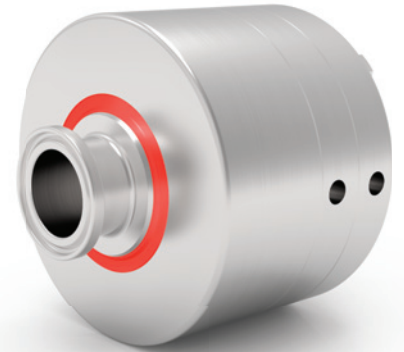

PART #	A	B	C	D	E	F	G	H	I
SCS-606010	4.10"	2.87"	2.25"	.72"	.92"	.63"	1.75"	3.44"	.87"
SCSM-606010	104.0mm	72.9mm	57.2mm	18.2mm	23.4mm	15.9mm	44.5mm	87.4mm	20.0mm

1 1/2" Connection: Dimensions

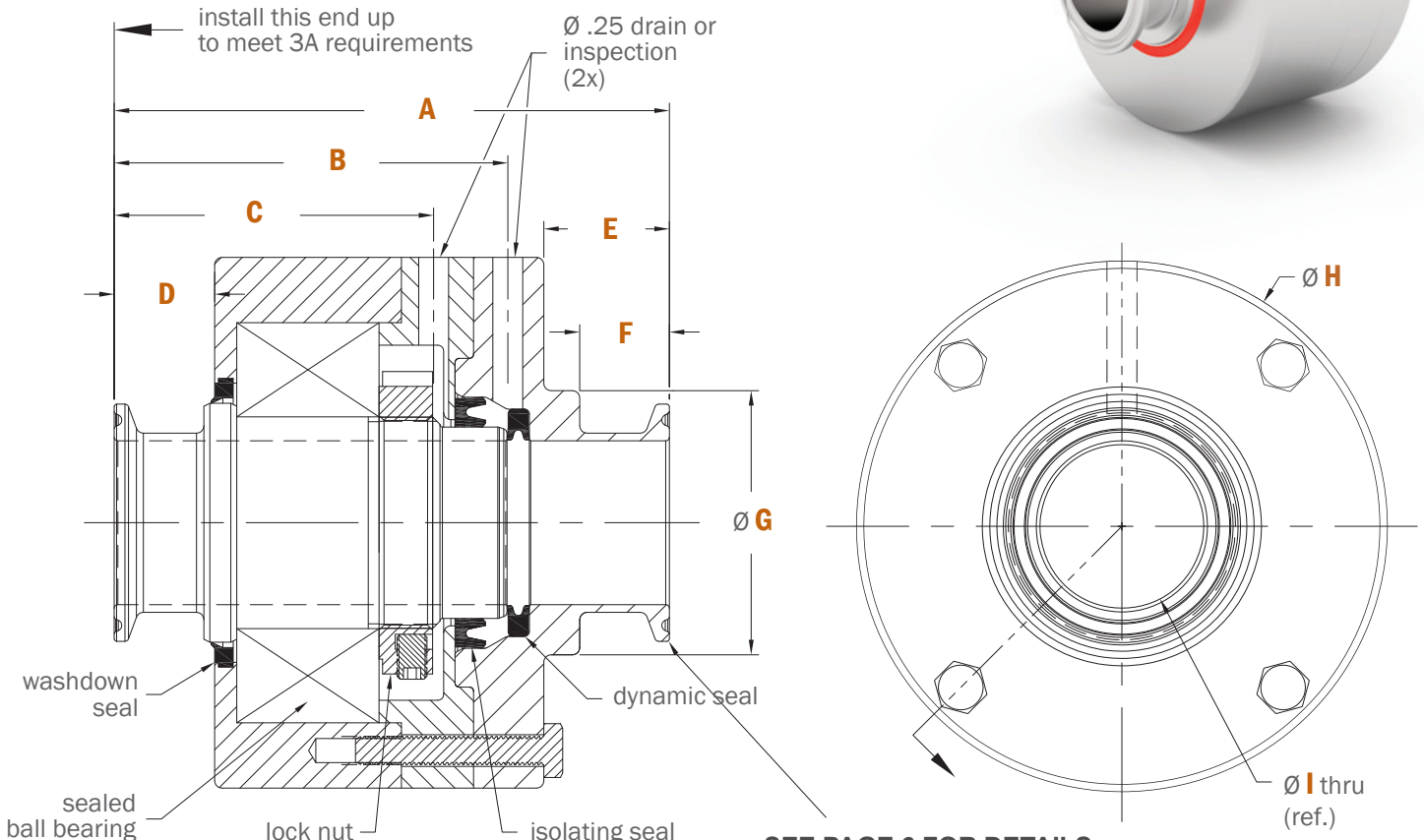
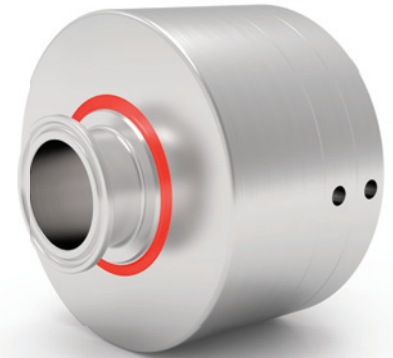

SEE PAGE 6 FOR DETAILS

hygienic clamp ferrule
 1 1/2" type B per ASME-BPE 2009
 [DN 32, series A, DIN 32676] (2x)

PART #	A	B	C	D	E	F	G	H	I
SCS-608010	4.64"	3.29"	2.67"	.84"	1.05"	.75"	2.21"	4.44"	1.37"
SCSM-608010	117.9mm	83.6mm	67.8mm	21.3mm	26.7mm	19.1mm	56.1mm	112.8mm	32.0mm

2" Connection: Dimensions

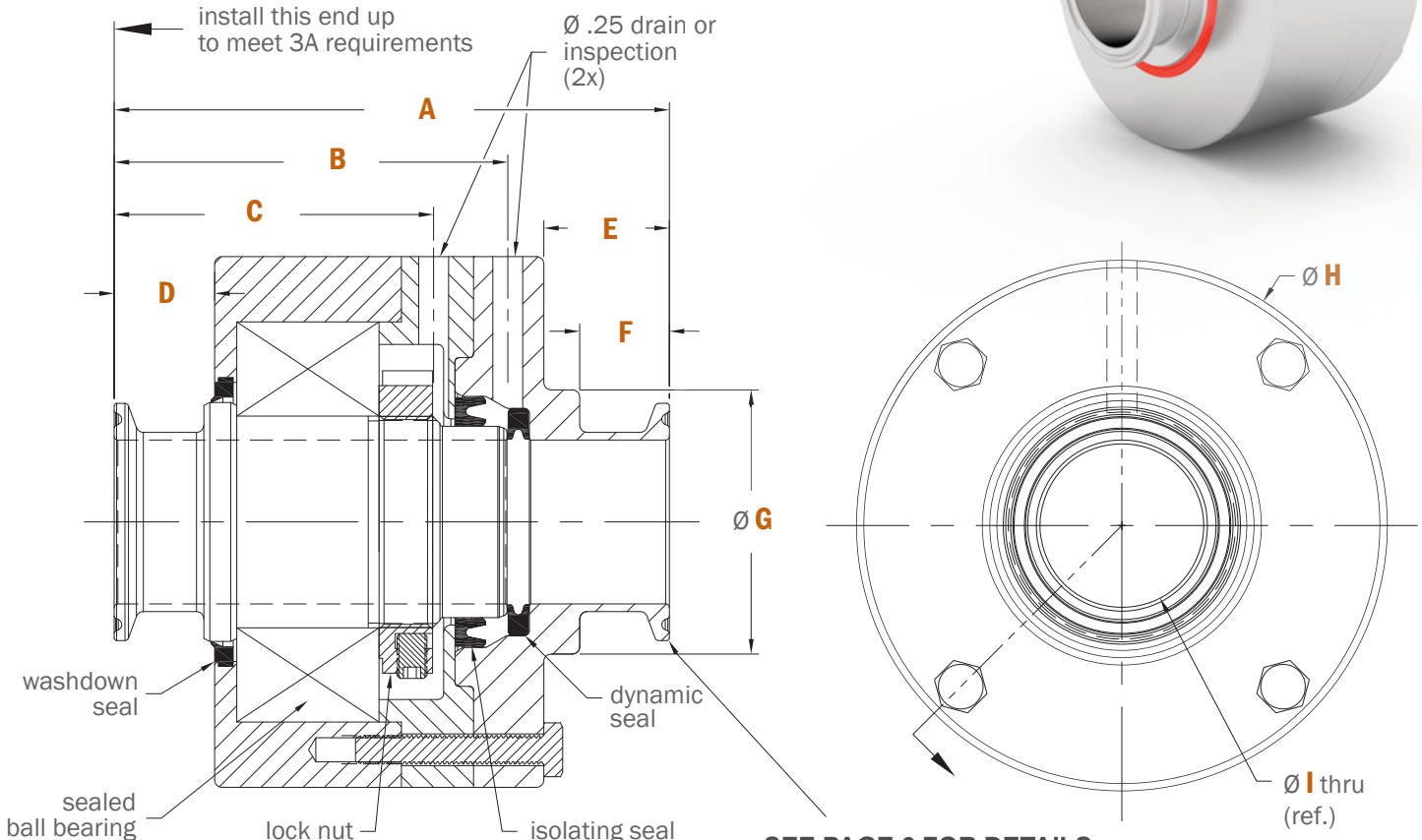
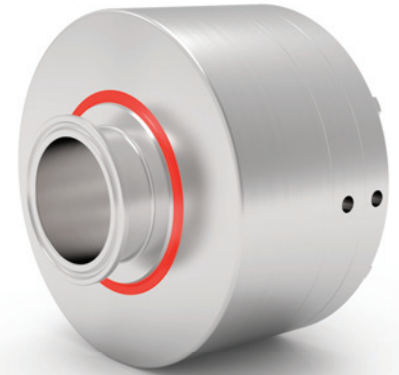

SEE PAGE 6 FOR DETAILS

hygienic clamp ferrule
 2" type B per ASME-BPE 2009
 [DN 50, series A, DIN 32676] (2x)

PART #	A	B	C	D	E	F	G	H	I
SCS-609010	4.99"	3.63"	2.98"	.84"	1.05"	.75"	2.75"	5.44"	1.87"
SCSM-609010	126.7mm	92.2mm	75.6mm	21.3mm	26.7mm	19.1mm	69.9mm	138.2mm	50.0mm

2 1/2" Connection: Dimensions

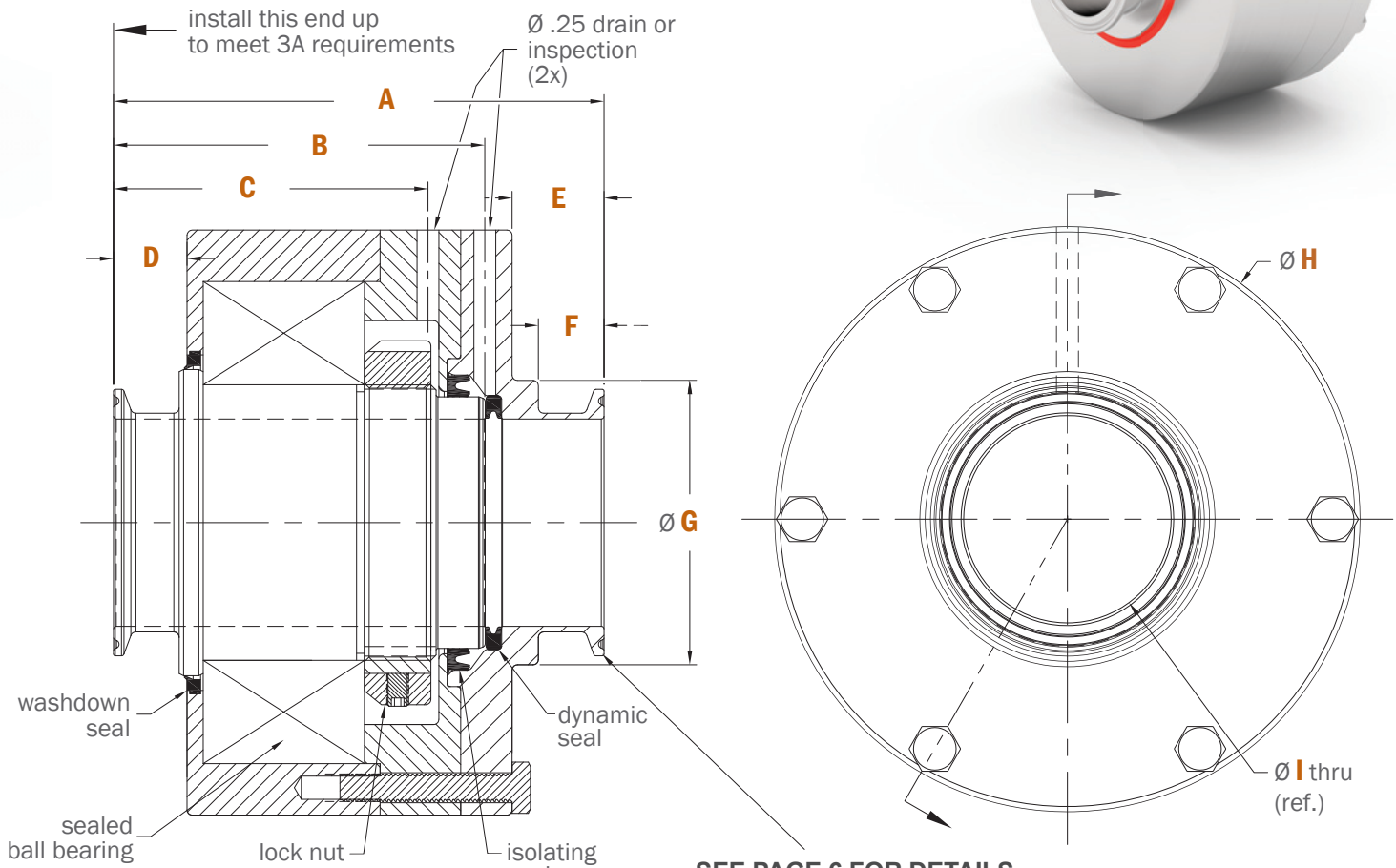
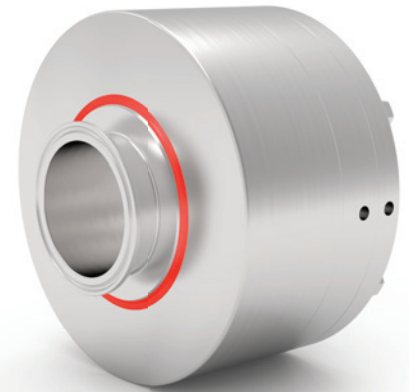

SEE PAGE 6 FOR DETAILS

hygienic clamp ferrule
 2 1/2" type B per ASME-BPE 2009
 [DN 65, series A, DIN 32676] (2x)

PART #	A	B	C	D	E	F	G	H	I
SCS-610010	5.61"	4.24"	3.59"	.84"	1.05"	.75"	3.25"	6.69"	2.37"
SCSM-610010	142.4mm	107.8mm	91.3mm	21.3mm	26.7mm	19.1mm	82.6mm	169.9mm	66.0mm

3" Connection: Dimensions

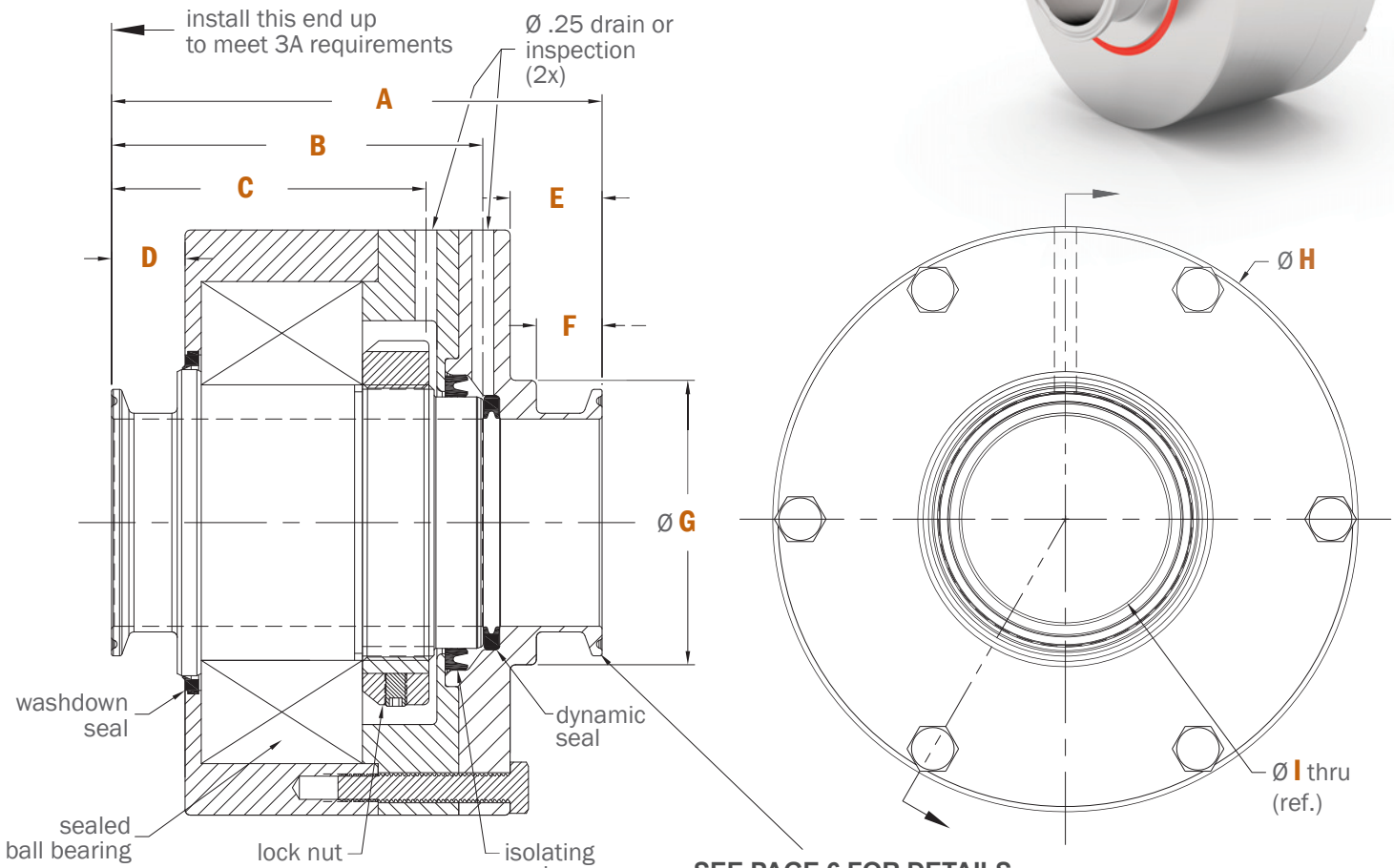
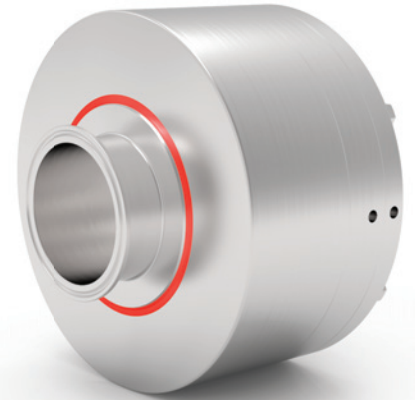

SEE PAGE 6 FOR DETAILS
 hygienic clamp ferrule
 3" type B per ASME-BPE 2009
 [DN 80, series A, DIN 32676] (2x)

PART #	A	B	C	D	E	F	G	H	I
SCS-611010	6.81"	5.20"	4.56"	1.25"	1.30"	1.00"	4.25"	7.94"	2.87"
SCSM-611010	173.1mm	132.1mm	115.8mm	31.6mm	33.0mm	25.4mm	108.0mm	201.7mm	81.0mm

4" Connection: Dimensions

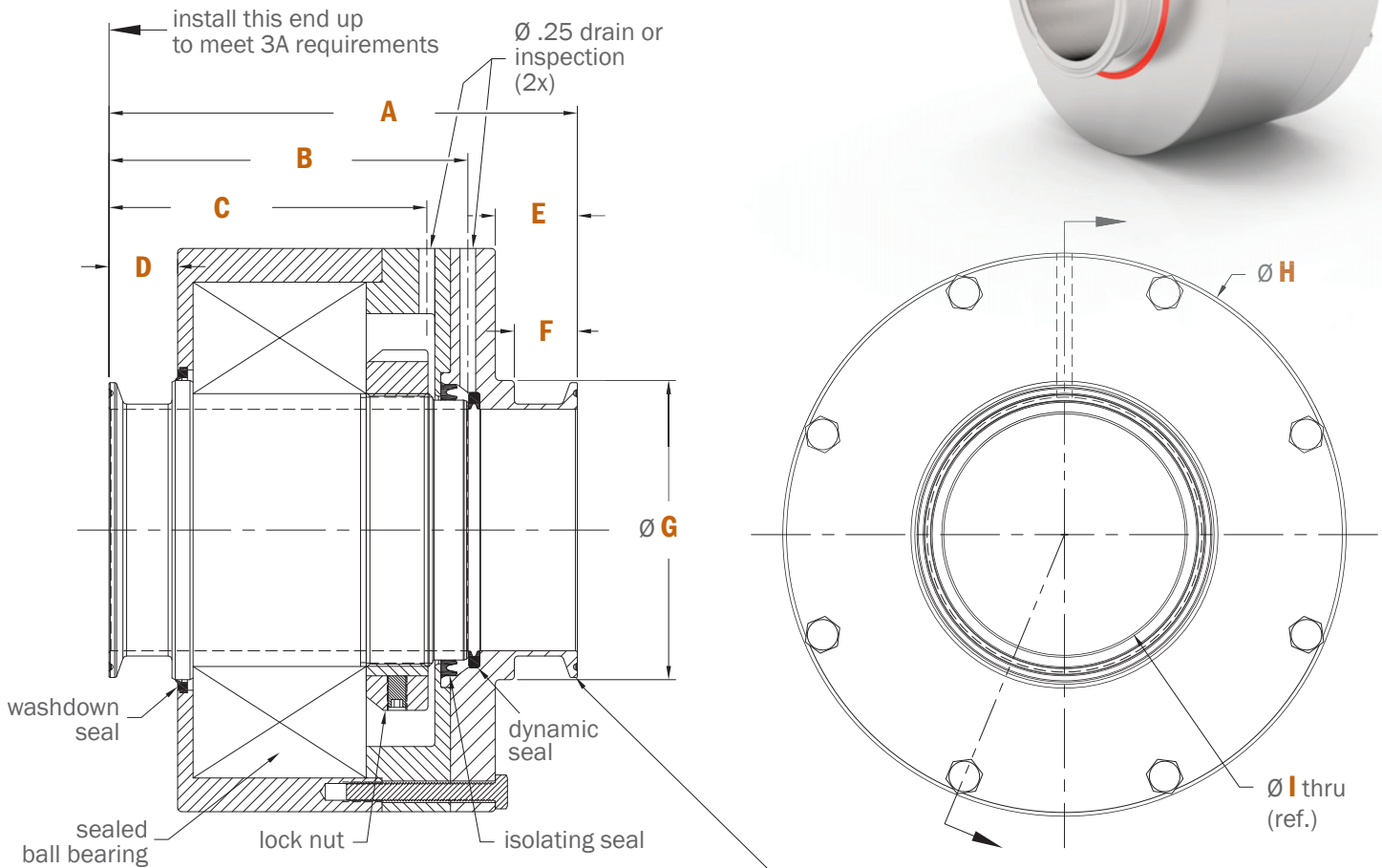
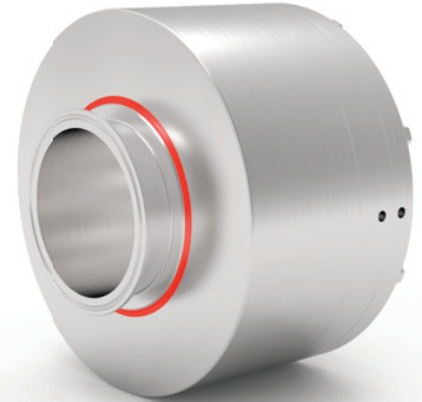

SEE PAGE 6 FOR DETAILS
 hygienic clamp ferrule
 4" type B per ASME-BPE 2009
 [DN 100, series A, DIN 32676] (2x)

PART #	A	B	C	D	E	F	G	H	I
SCS-613010	7.43"	5.70"	5.05"	.109"	1.30"	1.00"	4.75"	8.94"	3.83"
SCSM-613010	188.8mm	144.7mm	128.2mm	27.7mm	33.0mm	25.4mm	120.7mm	227.1mm	100.0mm

Installation & Mounting

PREPARATION:

Remove the rotary union from the shipping container. Inspect the entire assembly, including all passage connections to make sure that they are clean and no visual damage occurred during transport.

RECOMMENDED ROTARY UNION INSTALLATION PRACTICE:

As this device is mounted in line between two pipes, alignment of the pipes is critical. These pipes may have a wide variation of temperature during normal operation and cleaning, some flexibility must be included in the installation to absorb thermal expansion of the piping system. The sanitary flanged connections are the “torque arm” in this design. Make sure adequate / compatible gasket seals are installed between the flange connections. Orient drain / inspection ports as required. If the union is installed with a vertical centerline, note orientation mark, “this end up” and the arrow, in the etch on the union. Make sure clamp collars are tight.

INITIAL START-UP:

After rotary union is installed, a dry run is recommended to assure proper mounting of the rotating union assembly. Begin rotation of the equipment, and verify that while rotating at the maximum operating speed there is no visible movement of the rotary union assembly due to misalignment.

THESE INSTRUCTIONS ARE INTENDED TO BE USED AS A GENERAL GUIDE, PLEASE CONSULT DSTI TO DISCUSS ANY SPECIFIC QUESTIONS RELATED TO YOUR INSTALLATION.

WARRANTY:

DSTI Warrants, for a period of 2 years from the date of original delivery, its products to be free from defects in material and workmanship. DSTI's obligation under this warranty is limited to repair or replacement at its factory of any part or parts of said products which shall be returned to DSTI with transportation charges prepaid and which DSTI's examination shall disclose to its satisfaction to have been defective. Under no circumstances shall DSTI be held liable for loss, damage, cost of repair of consequential damages of any kind in connection with the sale, use or repair of any product purchased from DSTI. Warranty is subject to change.

Engineered Fluid Solutions

At DSTI, our product solutions are directly influenced by the industries we serve. If an existing product isn't a perfect fit for our customers' applications, we provide specialized design and manufacturing services to meet the needs of their specifications.

